

West Chester

— OHIO —

Trustees Meeting Agenda October 8, 2024

Trustees

Lee Wong, Chair
Mark S. Welch
Ann Becker

Fiscal Officer

Bruce Jones
Administrator
Larry D. Burks

6:00 P.M.

Regular Meeting

- Mr. Welch**
- Convene
 - Roll Call
 - Pledge

Citizen's Comments

(2 minutes per person limited to a total of 10 minutes)

Mr. Welch

Presentations

None

Mr. Burks

Personnel Items

1. Adm Accept various employee resignations per attached report
2. Fire Promote Nicholas Combs to the position of Fire Lieutenant at the hourly rate of \$35.56

Mr. Welch

Action Items - For approval by motion

3. Motion to approve Trustee Meeting Minutes - September 24, 2024
4. Motion to approve payment of bills - September 14, 2024 - September 27, 2024

Mr. Burks

Requisitions - Greater than \$7,500.00

5. Adm \$ 25,000.00 BluePaz LLC - Purchase Peer Support training
6. Adm \$ 20,000.00 The Wonder Within LLC - Purchase quarterly wellness sessions
7. Adm \$ 10,290.00 MP Digital LLC - Purchase user licenses
8. CIT \$ 28,910.00 Strategic Sourcing, Inc. - Replace mobile computers for EMS patient care reporting (CIP 1892)
9. Fire \$ 11,399.40 Vogelpohl Fire Equipment, Inc. - Purchase fire hose (CIP 1633)
10. Fire \$ 10,367.03 John Dsuban Spring Service - Repair rear axle on Vehicle 1118
11. Services \$ 57,636.93 Neyra Construction - Resurface driveway at Voice of America (CIP 1260)
12. Services \$ 52,334.34 Emcor Facilities Services, Inc. - Install parking lot lights at Muhlhauser Barn (CIP 1455)

October 8, 2024

Mr. Burks

Business Items

13. Police Motion not to object to a new D3 liquor permit for Pho Pham LLC dba Tasty Pho
7741 Tylers Place Boulevard

Resolutions

14. 1st Reading Resolution 38-2024 approving Major Change for Case #MC 05-24 The Gateway of
West Chester; Site D (To be read at public hearing)
15. 1st Reading Resolution 39-2024 approving Major Change for Case #ZMA 06-24
EnterTRAINment Junction; Place of Worship Redevelopment (To be read at public
hearing)

Citizen's Comments

Discussion Items & Elected Official Comments

Public Hearing

Case #MC 05-24 The Gateway of West Chester; Site D
Case #ZMA 06-24 EnterTRAINment Junction; Place of Worship Redevelopment

Adjourn

AGENDA ITEM COVER SHEET



Trustee Meeting Date:	Agenda Item Type:
October 8, 2024	Personnel Item
Submitted By:	
Tonya Pointer, Director of Human Resources	

Motion:
Accept various employee resignations per attached report

Background:

Finance	Budgeted Item:	N/A;		
	CIP #:			
	TIF Info:			
	Purchase Order:		Total Encumbrance:	\$.00

Last Name	First Name	Location De	Job Class Description	Inactive Date
GETTER	STEPHEN	FIRE	FIRE LIEUTENANT	06/04/2024
MULCOCK	DOUGLAS	FIRE	PT FIREFIGHTER	06/11/2024
JACKSON	ELI	POLICE	POLICE OFFICER	06/20/2024
HERZOG	JOEL	POLICE	POLICE CHIEF	07/01/2024
ANDERSON	ROBERT	FIRE	PT FIRE INSP/LOGISTICS	07/03/2024
MINTKENBA	TIMOTHY	POLICE	POLICE OFFICER RETIRE	07/26/2024
RYAN	KAYDA	PUBLIC INFC	PIE INTERN	07/27/2024
HUENING	DONALD	ROAD AND E	LABORER OPERATOR	07/31/2024
TAYLOR	DYLAN	UNION CENT	PART-TIME SERVICES	07/31/2024
MODINGER	DOMINIC	UNION CENT	PART-TIME SERVICES	08/07/2024
SMIDDY	WYATT	ROAD AND E	PART-TIME SERVICES	08/07/2024
SCOTT	JUDE	PARKS	PART-TIME SERVICES	08/08/2024
CONLIN	CAROLINE	PARKS	PART-TIME SERVICES	08/09/2024
SKERL	ANDREW	PARKS	PART-TIME SERVICES	08/14/2024
PRICE	LUCAS	CEMETERY	PART-TIME SERVICES	08/14/2024
MADDING	ANDREA	PUBLIC INFC	PIE INTERN	08/17/2024
LOVELL	BRADY	PARKS	PART-TIME SERVICES	08/23/2024
BARNHILL	CYNTHIA	ADMIN	HR SPECIALIST	09/20/2024

AGENDA ITEM COVER SHEET



Trustee Meeting Date:	Agenda Item Type:
October 8, 2024	Personnel Item
Submitted By:	
Rick L. Prinz, Fire Chief	

Motion:
Promote Nicholas Combs to the position of Fire Lieutenant at the hourly rate of \$35.56

Background:
<p>The Fire Department requests that the Board considers Firefighter Nicholas Combs to be promoted to the position of Career Fire/EMS Lieutenant.</p> <p>Firefighter Combs scored high among his peers throughout the promotional testing process.</p> <p>Firefighter Combs began his fire service career with the West Chester Fire Department when he was hired as a Firefighter/Paramedic in 2018. The Fire Department would like to recommend the promotion of Firefighter Nicholas Combs to Career Fire/EMS Lieutenant effective October 10, 2024 with a one year probation period at the hourly rate of \$35.56.</p>

Finance	Budgeted Item:	N/A;	
	CIP #:		
	TIF Info:		
	Purchase Order:	Total Encumbrance:	\$



**WEST CHESTER TOWNSHIP
ADMINISTRATION**

9113 Cincinnati-Dayton Road
West Chester, OH 45069-3840

T | 513-777-5900

F | 513-779-9369

westchesteroh.org

September 26, 2024

Mr. Nicholas Combs

Dear Mr. Combs:

I am pleased to extend a final offer you the position of Fire Lieutenant for West Chester Township. Although your official appointment will be October 8, 2024 at a regular West Chester Board of Trustees' meeting with an effective hire date October 10, 2024, the commitment to you regarding compensation, benefits, and related provisions is outlined herein:

General

Position:	Fire Lieutenant
Employer:	West Chester Township
Effective Hire Date:	October 10, 2024
Introductory Period:	365 days commencing on Hire Date

Compensation

Base Salary:	\$35.56 per hour
--------------	------------------

Benefits/Other Provisions

Benefits and other provisions will remain unchanged

Sincerely,

Larry D. Burks
Township Administration

AGENDA ITEM COVER SHEET



Trustee Meeting Date:	Agenda Item Type:
October 8, 2024	Action Item
Submitted By:	
Larry D. Burks, Township Administrator	

Motion:
Motion to approve Trustee Meeting Minutes - September 24, 2024

Background:

Finance	Budgeted Item:	N/A;		
	CIP #:			
	TIF Info:			
	Purchase Order:		Total Encumbrance:	\$.00

Record of Proceedings: September 24, 2024
West Chester Township Board of Trustees - Regular Meeting

Convene: Chairperson Wong convened the meeting at 5:00 p.m.
Roll Call: Mr. Wong and Mr. Welch responded. Mrs. Becker was absent.
Pledge of Allegiance: Repeated by those present.

MOTION made at 5:02 p.m. by Mr. Welch, seconded by Mr. Wong, to recess the Regular meeting and go into Executive Session with legal counsel for the purpose of: (1) To consider the purchase of property for public purposes, the sale of property by competitive bid, or the sale or other disposition of unneeded, obsolete, or unfit-for-use property in accordance with section 505.10 of the Revised Code. O.R.C. 121.22(G)(2); (2) conference with an attorney for the Township concerning disputes involving the Township that are the subject of pending or imminent court action. O.R.C. 121.22(G)(3); (3) to consider the appointment of public employee or official. O.R.C. 121.22(G)(1). Discussion: none. **Motion carried.** Mr. Wong said the Board would return to adjourn the Executive Session and to resume the Regular meeting. Mr. Wong declared the meeting in recess.

Post Executive Session/ Adjournment

MOTION made at 5:00 p.m. by Mr. Welch to adjourn the Executive Session and resume the September 24, 2024. Regular meeting, seconded by Mr. Wong. Discussion: none. **Motion carried.**

Citizen's Comments

There were no citizen's comments.

Presentations

Travis Bautz, MidPointe Library Executive Director, gave an update on their November levy.

Proclamation for Fire Prevention Week presented by Fire Chief Prinz.

Personnel Items

MOTION made by Mr. Welch, seconded by Mr. Wong, to approve collective bargaining agreement between West Chester Township Board of Trustees and Fraternal Order of Police, Ohio Labor Council, Inc. (FOP-OLC), effective October 1, 2024 to September 30, 2027. Discussion: Mr. Welch expressed appreciation for the union's preparedness and how quickly negotiations were concluded. **Motion carried.**

Action Items – For Approval by Motion

MOTION made by Mr. Wong, seconded by Mr. Welch, to approve the Trustee Meeting Minutes for September 10, 2024. Discussion: none. **Motion carried.**

MOTION made by Mr. Wong, seconded by Mr. Welch, to approve payment of bills – September 2, 2024 through September 13, 2024. Discussion: none. **Motion carried.**

Mr. Burks submitted the following requisitions greater than \$7,500:

7. Adm \$60,835.65 Frost Brown Todd LLC - Legal Services through August 31, 2024 (various departments)
8. CIT \$101,781.20 CentralSquare Technologies LLC - Renew annual license and support for public safety software
9. CIT \$29,425.00 Butler County Sheriff's Office - Purchase annual radio maintenance
10. PIE \$12,814.00 The Plant Detail - Purchase holiday decorating service for 1823 Plaza, The Square and Township Administration Building/Fire Headquarters
11. Services \$1,731,452.20 Jackson Construction, Inc. - Increase Purchase Order 20240990 to \$1,731,452.20 for replacement of curbs and gutters (CIP 1613 & 1936)
12. Services \$736,662.17 Benchmark Land Management LLC - Increase Purchase Order 20240991 to \$736,662.17 for replacement of pipes and curbs CIP 1613)
13. Services \$414,944.70 National Shotcrete LLC - Increase Purchase Order 20241117 to \$414,944.70 for replacement of storm pipes (CIP 1613)
14. Services \$8,400.00 Butler Tech & Career Dev Schools - Pay tuition for CDL training

Requisitions – Greater than \$7,500.00

MOTION made by Mr. Welch, seconded by Mr. Wong, to approve payment of requisitions 7 through 14. Discussion: In response to Mr. Welch’s question, Finance Director Keim addressed the Board, explaining that \$200,000 of ARPA funds were unobligated to date, though they are looking to apply it to replacement of curbs and pipes by the end of the year. **Motion carried.**

Business Items

MOTION made by Mr. Welch, seconded by Mr. Wong, to approve Resolution 36-2024 authorizing the acceptance of the proposed agreed entry resolving the West Chester Township Board of Trustees case involving the property at 7809 Cincinnati Dayton Road. Discussion: **Motion carried.**

MOTION made by Mr. Welch, seconded by Mr. Wong, to approve agreement between West Chester Township Board of Trustees and Schumacher Construction Management Inc not to exceed \$69,346.00; and, authorize Township Administrator to make non-substantive changes with Law Director approval and execute said agreement. Discussion: In response to Mr. Welch’s question, Mr. Burks said insurance was paying a portion of the cost. **Motion carried.**

MOTION made by Mr. Welch, seconded by Mr. Wong, to approve Resolution 37-2024 finding one accessible van not needed or unfit for public use. Discussion: none. **Motion carried.**

MOTION made by Mr. Welch, seconded by Mr. Wong, to not object to a new C1, C2, D3 liquor permit for Upside Petroleum LLC, dba Stop n Go, 9655 Cincinnati Dayton Road. Discussion: none. **Motion carried.**

MOTION made by Mr. Welch, seconded by Mr. Wong, to not object to a new C1, C2, D3, D3A liquor permit for West Chester Petroleum LLC, dba CinDay Shell, 8573 Cincinnati Dayton Road. Discussion: none. **Motion carried.**

MOTION made by Mr. Welch, seconded by Mr. Wong, to accept the donation of one dual purpose canine and training from the Jimenez Family. Discussion: none. **Motion carried.**

MOTION made by Mr. Welch, seconded by Mr. Wong, to approve agreement between West Chester Township Board of Trustees and the Ohio Department of Transportation for maintenance at the I-75 Union Centre Blvd interchange; and, authorize Township Administrator to make nonsubstantive changes with Law Director approval and execute said agreement. Discussion: none. **Motion carried.**

MOTION made by Mr. Welch, seconded by Mr. Wong, to approve agreement between West Chester Township Board of Trustees and Duke Energy for street light replacement not to exceed \$46,476.31; and, authorize Township Administrator to execute all documents necessary to effectuate the project with Law Director approval (CIP 1731). Discussion: none. **Motion carried.**

MOTION made by Mr. Welch, seconded by Mr. Wong, to approve agreement between West Chester Township Board of Trustees and the State of Ohio for Temporary Construction and Access Easement; and, authorize Township Administrator to make non-substantive changes with Law Director approval and execute said agreement. Discussion: none. **Motion carried.**

Resolutions

There were no resolutions.

Citizen's Comments

There were no citizen's comments.

Discussion Items & Elected Official Comments

Mr. Wong noted Pumpkinfest was soon.

Mr. Welch gave clarifying comments pertaining to the Solara Public Hearing at the last meeting.

Mr. Jones thanked the Lord for rain.

Adjournment

MOTION made at 6:41 p.m. by Mr. Welch, seconded by Mr. Wong, to adjourn the September 24, 2024 Regular meeting. Discussion: none. **Motion carried.**

Respectfully Submitted,

Approved,

Bruce Jones, Fiscal Officer

Lee Wong, Chairperson

DRAFT

AGENDA ITEM COVER SHEET



Trustee Meeting Date:	Agenda Item Type:
October 8, 2024	Action Item
Submitted By:	
Kenneth Keim, Director of Finance	

Motion:
Motion to approve payment of bills - September 14, 2024 - September 27, 2024

Background:

Finance	Budgeted Item:	N/A;	
	CIP #:		
	TIF Info:		
	Purchase Order:		Total Encumbrance:

AP CHECK RECONCILIATION REGISTER

FOR CASH ACCOUNT: 9999-00-0000-10110-000000-000000

FOR: All Except Stale

CHECK #	CHECK DATE	TYPE	VENDOR NAME	UNCLEARED	CLEARED	BATCH	CLEAR DATE
2397	09/13/2024	MANUAL	003159 CHARTER COMMUNICATIONS		45.32	1	09/16/2024
	INVOICE NO		ACCOUNT		AMOUNT		
	0227194	08/30/24	2030-RD-RD00-55060-000000-		45.32		
2412	09/13/2024	MANUAL	003159 CHARTER COMMUNICATIONS	181.34			
	135356201090124		2100-FD-FD00-55060-000000-		181.34		
2413	09/13/2024	MANUAL	003159 CHARTER COMMUNICATIONS	404.69			
	135356301090724		2070-PI-PI00-55060-000000-		404.69		
2414	09/18/2024	MANUAL	000917 BWC	115,030.09			
	1019355144		1010-AD-AD00-52240-000000-		5,172.38		
	1019355144		1010-AD-AD02-52240-000000-		300.18		
	1019355144		1010-AD-AD03-52240-000000-		156.65		
	1019355144		1010-CD-CD00-52240-000000-		2,614.33		
	1019355144		1010-PK-PK00-52240-000000-		808.08		
	1019355144		1010-SV-SV00-52240-000000-		1,360.82		
	1019355144		2040-RD-RD00-52240-000000-		5,278.19		
	1019355144		2050-CE-CE00-52240-000000-		781.18		
	1019355144		2070-PI-PI00-52240-000000-		1,620.89		
	1019355144		2090-DS-DS00-52240-000000-		3,919.97		
	1019355144		2090-PD-PD00-52240-000000-		46,347.91		
	1019355144		2100-DS-DS00-52240-000000-		2,110.75		
	1019355144		2100-FD-FD00-52240-000000-		41,107.16		
	1019355144		2110-EM-EM00-52240-000000-		3,104.03		
	1019355144		5080-RD-RD00-52240-000000-		347.57		
2415	09/20/2024	MANUAL	000900 UNITED STATES TREASURY	107,452.20			
	09/20/24		1010-00-0000-22010-000000-000000		107,452.20		
402381	09/13/2024	EFT	002414 4IMPRINT		2,840.20	1	09/13/2024
	12945822		2070-PI-PI00-54010-000000-		418.86		
	12924958		2070-PI-PI00-56030-FARMER-		2,421.34		
402382	09/13/2024	EFT	001532 A-PLUS CONCRETE & EXCAVAT		64.00	1	09/13/2024
	12305		2040-RD-RD00-54550-IHCLVT-		64.00		
402383	09/13/2024	EFT	000008 ACE HARDWARE W.C. INC.		23.96	1	09/13/2024
	37069/1		2010-RD-RD01-54550-000000-		23.96		
402384	09/13/2024	EFT	000016 AERO OIL COMPANY OF CINCI		877.25	1	09/13/2024
	190456		2090-PD-PD00-53510-000000-		877.25		
402385	09/13/2024	EFT	003174 AMAZON FULLFILLMENT SERVI		1,172.63	1	09/13/2024
	16YQ-VQ1N-6QHG		2100-FD-FD00-54510-000000-		41.93		
	1Q9R-JLKF-9QK6		2070-PI-PI00-54010-000000-		679.99		
	1NKW-JXCR-FTV9		1010-AD-AD00-54810-000000-		40.77		
	1NKW-JXCR-FTV9		1010-CD-CD00-54810-000000-		16.31		
	1NKW-JXCR-FTV9		2010-RD-RD00-54810-000000-		19.03		
	1NKW-JXCR-FTV9		2070-PI-PI00-54810-000000-		5.44		

AP CHECK RECONCILIATION REGISTER

FOR CASH ACCOUNT: 9999-00-0000-10110-000000-000000

FOR: All Except Stale

CHECK #	CHECK DATE	TYPE	VENDOR NAME	UNCLEARED	CLEARED	BATCH	CLEAR DATE
			1NKW-JXCR-FTV9	2090-DS-DS00-54810-000000-	5.44		
			INVOICE NO	ACCOUNT	AMOUNT		
			1NKW-JXCR-FTV9	2090-PD-PD00-54810-000000-	114.16		
			1NKW-JXCR-FTV9	2100-DS-DS00-54810-000000-	5.41		
			1NKW-JXCR-FTV9	2100-FD-FD00-54810-000000-	32.62		
			1NKW-JXCR-FTV9	2110-EM-EM00-54810-000000-	32.62		
			13DR-91GT-CR7V	2090-DS-DS00-56050-000000-	59.81		
			13DR-91GT-CR7V	2100-DS-DS00-56050-000000-	59.80		
			1D4J-VJGP-3W1L	2090-PD-PD00-54010-000000-	24.97		
			1LXH-RL96-WFCX	1010-CD-CD00-54510-000000-	65.95		
			1CT3-C3XQ-FWM9	2100-FD-FD00-54010-000000-	-31.62		
402386	09/13/2024	EFT	004156 ARC DOCUMENT SOLUTIONS LL 2700-PD-PD00-54010-000000-		2,990.00	1	09/13/2024
					2,990.00		
402387	09/13/2024	EFT	002918 NST 2 BATTERY LLC 2010-RD-RD00-53190-000000-		42.50	1	09/13/2024
					42.50		
402388	09/13/2024	EFT	000126 BOUND TREE MEDICAL LLC. 85476703 85478492	2110-EM-EM00-54550-000000- 2110-EM-EM00-54550-000000-	6,576.00 647.80 5,928.20	1	09/13/2024
402389	09/13/2024	EFT	000192 OHIO NEWSPAPERS INC 09/11/24	1010-AD-AD00-53720-000000-	150.48 150.48	1	09/13/2024
402390	09/13/2024	EFT	000235 ECON-O-WISE RENTAL 319722	1010-PK-PK00-53560-000000-	312.88 312.88	1	09/13/2024
402391	09/13/2024	EFT	000634 EMCOR FACILITIES SERVICES		44,788.16	1	09/13/2024
			614161A	1010-AD-AD00-53530-000000-	2,936.97		
			614161A	1010-CD-CD00-53530-000000-	2,447.48		
			614161A	2010-RD-RD00-53530-000000-	4,160.71		
			614161A	2090-PD-PD00-53530-000000-	14,986.29		
			614162	1010-AD-AD00-53530-000000-	5,426.55		
			614162	2070-PI-PI00-53530-000000-	736.97		
			614163	1010-AD-AD00-53530-000000-	2,686.37		
			614163	2090-DS-DS00-53530-000000-	1,343.18		
			614163	2100-DS-DS00-53530-000000-	1,343.17		
			614165	1010-PK-PK03-53530-000000-	369.08		
			614165	1010-PK-PK04-53530-000000-	75.84		
			614165	1010-PK-PK11-53530-000000-	948.23		
			614165	1010-PK-PK12-53530-000000-	62.22		
			614166	2050-CE-CE00-53530-000000-	945.07		
			614167B	1010-AD-AD00-53530-000000-	296.16		
			614167B	1010-CD-CD00-53530-000000-	246.80		
			614167B	2010-RD-RD00-53530-000000-	419.56		
			614167B	2090-PD-PD00-53530-000000-	1,505.49		
			614167C	1010-SV-SV00-53530-000000-	1,102.02		
			614169	1010-PK-PK11-53530-000000-	2,750.00		

AP CHECK RECONCILIATION REGISTER

FOR CASH ACCOUNT: 9999-00-0000-10110-000000-000000

FOR: All Except Stale

CHECK #	CHECK DATE	TYPE	VENDOR NAME	UNCLEARED	CLEARED	BATCH	CLEAR DATE
402392	09/13/2024	EFT	002795 EQUIFAX INFORMATION SERVI		60.16	1	09/13/2024
			INVOICE NO	ACCOUNT	AMOUNT		
			2062053656	2090-PD-PD00-53190-000000-	60.16		
402393	09/13/2024	EFT	004388 IRIS GROUP HOLDINGS LLC		53.05	1	09/13/2024
			156151365	1010-AD-AD00-53530-000000-	6.36		
			156151365	1010-CD-CD00-53530-000000-	5.31		
			156151365	2010-RD-RD00-53530-000000-	9.02		
			156151365	2090-PD-PD00-53530-000000-	32.36		
402394	09/13/2024	EFT	000277 GALLS, LLC		2,311.47	1	09/13/2024
			028758601	2090-PD-PD00-54720-000000-	848.32		
			028771155	2090-PD-PD00-54720-000000-	154.00		
			028788211	2090-PD-PD00-54720-000000-	878.24		
			BC1918999	2090-PD-PD00-54720-000000-	53.40		
			028992311	2090-PD-PD00-54720-000000-	377.51		
402395	09/13/2024	EFT	002788 HIGHTOWERS PETROLEUM CO.		26,639.56	1	09/13/2024
			126254	1010-00-0000-11060-000000-000000	26,639.56		
402396	09/13/2024	EFT	000320 HORTON EMERGENCY VEHICLES		96.57	1	09/13/2024
			191007	2110-EM-EM00-53510-000000-	96.57		
402397	09/13/2024	EFT	000373 KLEEM INC.		185.68	1	09/13/2024
			102597	2010-RD-RD01-54550-000000-	185.68		
402398	09/13/2024	EFT	001462 LANGUAGE LINE SERVICES		287.51	1	09/13/2024
			11388194	2090-PD-PD00-53190-000000-	287.51		
402399	09/13/2024	EFT	003062 LEXIS NEXIS RISK DATA MAN		867.58	1	09/13/2024
			1591256-20240831	2090-PD-PD00-53170-000000-	867.58		
402400	09/13/2024	EFT	001934 WORLD FUEL SERVICES		4,238.34	1	09/13/2024
			August 2024	1010-PK-PK00-54710-000000-	499.44		
			August 2024	2030-RD-RD00-54710-000000-	2,524.31		
			August 2024	2050-CE-CE00-54710-000000-	92.44		
			August 2024	2090-PD-PD00-54710-000000-	100.23		
			August 2024	2100-FD-FD00-54710-000000-	222.57		
			August 2024	2110-EM-EM00-54710-000000-	799.35		
402401	09/13/2024	EFT	002441 MENARD, INC.		327.32	1	09/13/2024
			84265	2010-RD-RD00-53530-000000-	267.95		
			83874	1010-PK-PK12-53530-STREET-	47.39		
			83654	1010-SV-SV99-54010-000000-	11.98		
402402	09/13/2024	EFT	003481 NATIONAL SHOTCRETE LLC		126,190.00	1	09/13/2024
			1650	2750-AD-AD00-57040-ARPA21-	56,388.00		
			1651	2750-AD-AD00-57040-ARPA21-	69,802.00		
402403	09/13/2024	EFT	003478 O'REILLY AUTO ENTERPRISES		307.64	1	09/13/2024

AP CHECK RECONCILIATION REGISTER

FOR CASH ACCOUNT: 9999-00-0000-10110-000000-000000

FOR: All Except Stale

CHECK #	CHECK DATE	TYPE	VENDOR NAME	UNCLEARED	CLEARED	BATCH	CLEAR DATE
	1738-390631		1010-PK-PK00-53560-000000-		64.08		
	INVOICE NO		ACCOUNT	AMOUNT			
	1738-391654		2010-RD-RD00-53510-000000-		28.07		
	1738-388971		2010-RD-RD00-53510-000000-		215.49		
402404	09/13/2024	EFT	000474 ONE STOP TOOL RENTAL 1010-PK-PK04-53550-000000-		370.00 370.00	1	09/13/2024
402405	09/13/2024	EFT	003378 PATH MASTER, INC. 2100-FD-FD00-54550-000000-		4,294.00 4,294.00	1	09/13/2024
402406	09/13/2024	EFT	003578 PLUTO ACQUISITION OPCO LL 2070-PI-PI00-53230-000000-		32.82 32.82	1	09/13/2024
402407	09/13/2024	EFT	003853 QUADIENT FINANCE USA INC 1010-AD-AD00-53730-000000-		1,000.00 1,000.00	1	09/13/2024
402408	09/13/2024	EFT	003265 MULTI SERVICE TECHNOLOGY 2010-RD-RD00-54720-000000- 2050-CE-CE00-54720-000000-		499.85 249.85 250.00	1	09/13/2024
402409	09/13/2024	EFT	003228 SMYRNA READY MIX CONCRETE 2040-RD-RD00-54550-IHCLVT- 2040-RD-RD00-54550-IHPAVE-		1,832.00 1,220.00 612.00	1	09/13/2024
402410	09/13/2024	EFT	002609 STIGLER SUPPLY CO. 2100-FD-FD00-54550-000000-		684.00 684.00	1	09/13/2024
402411	09/13/2024	EFT	003198 STRYKER SALES LLC 2110-EM-EM00-53510-000000-		732.00 732.00	1	09/13/2024
402412	09/13/2024	EFT	000536 SUPERIOR IMPLEMENT SUPPLY 1010-PK-PK00-53560-000000- 1010-PK-PK00-53560-000000-		208.84 149.00 59.84	1	09/13/2024
402413	09/13/2024	EFT	003909 CITY OF TRENTON 2090-PD-PD00-51120-000000- 2090-PD-PD00-51120-000000-		2,795.00 455.00 2,340.00	1	09/13/2024
402414	09/13/2024	EFT	003219 TRI-STATE PUBLIC SAFETY 2090-PD-PD00-53510-000000- 2090-PD-PD00-53510-000000- 2100-FD-FD00-54010-000000-		981.00 80.00 745.00 156.00	1	09/13/2024
402415	09/13/2024	EFT	000573 VALLEY ASPHALT CORPORATIO 2040-RD-RD00-54550-IHPAVE-		693.00 693.00	1	09/13/2024
402416	09/13/2024	EFT	003680 WEX INC 2100-FD-FD00-54710-000000- 2110-EM-EM00-54710-000000-		10,070.23 5,035.11 5,035.12	1	09/13/2024

AP CHECK RECONCILIATION REGISTER

FOR CASH ACCOUNT: 9999-00-0000-10110-000000-000000

FOR: All Except Stale

CHECK #	CHECK DATE	TYPE	VENDOR NAME	UNCLEARED	CLEARED	BATCH	CLEAR DATE
402417	09/20/2024	EFT	001532 A-PLUS CONCRETE & EXCAVAT	32.00			
			INVOICE NO	ACCOUNT	AMOUNT		
			12353	1010-PK-PK04-53530-000000-	32.00		
402418	09/20/2024	EFT	003800 ADW ACQUISITIONS LLC	156.28			
	18180717		2110-EM-EM00-53510-000000-		156.28		
402419	09/20/2024	EFT	000016 AERO OIL COMPANY OF CINCI	877.25			
	190486		2010-RD-RD00-53510-000000-		438.63		
	190486		2100-FD-FD00-53510-000000-		219.31		
	190486		2110-EM-EM00-53510-000000-		219.31		
402420	09/20/2024	EFT	002469 AFLAC GROUP INSURANCE - G	1,436.43			
	WCTWP-9325	Sep 2024	1010-00-0000-22220-000000-000000		1,436.43		
402421	09/20/2024	EFT	002422 AFSCME OHIO COUNCIL 8, LO	497.70			
	09/20/24	Union Dues	1010-00-0000-22510-000000-000000		497.70		
402422	09/20/2024	EFT	003337 AIRGAS, INC.	370.99			
	5510333027		2010-RD-RD00-53550-000000-		57.28		
	5510324085		2110-EM-EM00-54550-000000-		313.71		
402423	09/20/2024	EFT	002035 AL-JOE'S INC	239.98			
	1060931		2010-RD-RD00-54010-000000-		239.98		
402424	09/20/2024	EFT	003174 AMAZON FULLFILLMENT SERVI	998.38			
	1MKF-KXWP-13MG		1010-PK-PK11-53530-000000-		37.58		
	1MKF-KXWP-13MG		1010-SV-SV00-54510-000000-		48.99		
	1D1H-WMPY-1GQR		2010-RD-RD00-54720-000000-		229.98		
	1PNT-DGLQ-C7CD		1010-PK-PK04-53530-000000-		33.54		
	1PNT-DGLQ-C7CD		1010-SV-SV00-54510-000000-		10.99		
	1W64-9TMX-PTCT		2100-FD-FD00-54010-000000-		38.61		
	1QNY-1TYX-WYR4		1010-PK-PK10-54550-000000-		13.99		
	1QNY-1TYX-WYR4		1010-SV-SV00-54510-000000-		121.58		
	1QNY-1TYX-WYR4		2010-RD-RD00-53560-000000-		139.95		
	1QNY-1TYX-WYR4		2010-RD-RD00-54010-000000-		222.53		
	1NQ3-7D9P-GV1M		2100-FD-FD00-54510-000000-		41.12		
	17GM-MKFG-HXH7		1010-AD-AD00-54510-000000-		68.97		
	1KJ7-4QQH-7MYT		1010-AD-AD00-54510-000000-		301.06		
	1VLM-PY4P-3KV1		2090-PD-PD00-54010-000000-		-310.51		
402425	09/20/2024	EFT	000117 BETHESDA HEALTHCARE INC.	3,116.00			
	6280-493206		2100-FD-FD00-53190-000000-		3,116.00		
402426	09/20/2024	EFT	000126 BOUND TREE MEDICAL LLC.	2,279.86			
	85392054		2110-EM-EM00-54550-000000-		654.50		
	85469487		2110-EM-EM00-54550-000000-		1,118.96		
	85485408		2110-EM-EM00-54550-000000-		506.40		

AP CHECK RECONCILIATION REGISTER

FOR CASH ACCOUNT: 9999-00-0000-10110-000000-000000

FOR: All Except Stale

CHECK #	CHECK DATE	TYPE	VENDOR NAME	UNCLEARED	CLEARED	BATCH	CLEAR DATE
402427	09/20/2024	EFT	001346 CAPITAL ELECTRIC LINE BUI	639.05			
	INVOICE NO		ACCOUNT		AMOUNT		
	92103		2100-FD-FD00-54550-000000-		639.05		
402428	09/20/2024	EFT	003558 CENTRALSQUARE TECHNOLOGIE	9,200.10			
	418077		2090-PD-PD00-54820-000000-		4,600.05		
	418077		2100-FD-FD00-54820-000000-		2,300.03		
	418077		2110-EM-EM00-54820-000000-		2,300.02		
402429	09/20/2024	EFT	004391 CINCY COMPANY LLC	3,750.00			
	0563465		2070-PI-PI00-53720-000000-		3,750.00		
402430	09/20/2024	EFT	004326 CLINTON COUNTY MOTORSPORT	47,738.97			
	290005		2100-FD-FD00-57060-000000-		47,738.97		
402431	09/20/2024	EFT	004227 EMPOWER RETIREMENT LLC	1,595.00			
	09/20/24		1010-00-0000-22010-000000-000000		530.00		
	09/20/24		1010-00-0000-22520-000000-000000		1,065.00		
402432	09/20/2024	EFT	003763 THE FECHHEIMER BROTHERS C	1,132.33			
	000421184		2700-PD-PD00-54720-000000-		766.22		
	000422837		2090-PD-PD00-54720-000000-		366.11		
402433	09/20/2024	EFT	003450 FERGUSON US HOLDINGS INC	268.70			
	0916350		1010-PK-PK12-53530-000000-		153.49		
	0915472		1010-PK-PK12-53530-000000-		115.21		
402434	09/20/2024	EFT	003236 FIRST RESPONDER OUTFITTER	1,071.00			
	9367-3		2700-PD-PD00-54720-000000-		535.50		
	9292-3		2090-PD-PD00-54720-000000-		535.50		
402435	09/20/2024	EFT	000754 F.O.P. LODGE #186	2,025.00			
	FOP 186 09/20/24		1010-00-0000-22510-000000-000000		2,025.00		
402436	09/20/2024	EFT	002442 FOX TOWING INC.	350.00			
	253002		2090-PD-PD00-53240-000000-		350.00		
402437	09/20/2024	EFT	000277 GALLS, LLC	5,841.91			
	029051394		2090-PD-PD00-54720-000000-		22.43		
	028752316		2100-FD-FD00-54720-000000-		260.45		
	028619275		2100-FD-FD00-54720-000000-		168.95		
	028658545		2100-FD-FD00-54720-000000-		505.86		
	028595556		2100-FD-FD00-54720-000000-		142.99		
	028781786		2100-FD-FD00-54720-000000-		118.04		
	028771273		2100-FD-FD00-54720-000000-		105.95		
	028632007		2100-FD-FD00-54720-000000-		170.50		
	028659868		2100-FD-FD00-54720-000000-		17.04		
	028623959		2100-FD-FD00-54720-000000-		23.34		
	028632289		2100-FD-FD00-54720-000000-		156.55		
	028594516		2100-FD-FD00-54720-000000-		146.21		

AP CHECK RECONCILIATION REGISTER

FOR CASH ACCOUNT: 9999-00-0000-10110-000000-000000

FOR: All Except Stale

CHECK #	CHECK DATE	TYPE	VENDOR NAME	UNCLEARED	CLEARED	BATCH	CLEAR DATE
	028573580		2100-FD-FD00-54720-000000-		173.00		
	INVOICE NO		ACCOUNT		AMOUNT		
	028605500		2100-FD-FD00-54720-000000-		290.18		
	028775554		2100-FD-FD00-54720-000000-		478.40		
	028593373		2100-FD-FD00-54720-000000-		160.83		
	028582194		2100-FD-FD00-54720-000000-		233.82		
	028574014		2100-FD-FD00-54720-000000-		60.26		
	028565408		2100-FD-FD00-54720-000000-		21.00		
	028682360		2100-FD-FD00-54720-000000-		70.42		
	028739421		2100-FD-FD00-54720-000000-		132.41		
	028670369		2100-FD-FD00-54720-000000-		260.23		
	028776757		2100-FD-FD00-54720-000000-		500.07		
	028615183		2100-FD-FD00-54720-000000-		70.70		
	028583948		2100-FD-FD00-54720-000000-		110.00		
	028605505		2100-FD-FD00-54720-000000-		145.87		
	028701557		2100-FD-FD00-54720-000000-		268.51		
	028811942		2100-FD-FD00-54720-000000-		205.86		
	028626509		2100-FD-FD00-54720-000000-		70.34		
	028593415		2100-FD-FD00-54720-000000-		146.82		
	028694726		2100-FD-FD00-54720-000000-		204.46		
	028603905		2100-FD-FD00-54720-000000-		303.66		
	028593385		2100-FD-FD00-54720-000000-		73.41		
	028623966		2100-FD-FD00-54720-000000-		23.35		
402438	09/20/2024	EFT	003047 ROQUEMORE ENTERPRISES INC 2021-5658	6,565.00	6,565.00		
402439	09/20/2024	EFT	003235 MAGNET FORENSICS USA, INC SIN072409	2,710.00	2,710.00		
402440	09/20/2024	EFT	003779 IMPERIAL BAG & PAPER CO L 35354013 35354013	1,137.57	1,110.69 26.88		
402441	09/20/2024	EFT	000410 MCGILL SMITH PUNSHON INC. 1010-PK-PK05-57010-000000-	14,632.34	14,632.34		
402442	09/20/2024	EFT	000424 MIAMI UNIVERSITY VOACMF 2024 A	240.00	240.00		
402443	09/20/2024	EFT	000442 MOTOROLA SOLUTIONS, INC. 8281974618	3,197.20	3,197.20		
402444	09/20/2024	EFT	003478 O'REILLY AUTO ENTERPRISES 1738-392334 1738-392618 1738-392372 1738-391950 1738-391711 1738-391676	1,353.03	316.90 201.15 -44.00 42.28 100.25 625.02		

AP CHECK RECONCILIATION REGISTER

FOR CASH ACCOUNT: 9999-00-0000-10110-000000-000000

FOR: All Except Stale

CHECK #	CHECK DATE	TYPE	VENDOR NAME	UNCLEARED	CLEARED	BATCH	CLEAR DATE
	1738-390838		2010-RD-RD00-53510-000000-		123.66		
	INVOICE NO		ACCOUNT	AMOUNT			
	1738-391937		2010-RD-RD00-53510-000000-		46.53		
	1738-393913		1010-AD-AD00-53510-000000-		34.30		
	1738-391949		2010-RD-RD00-53510-000000-		-46.53		
	1738-391966		2010-RD-RD00-53510-000000-		-17.64		
	1738-391966B		2010-RD-RD00-53510-000000-		-28.89		
402445	09/20/2024	EFT	003439 PENN CARE INC 2110-EM-EM00-54550-000000-	777.60	777.60		
402446	09/20/2024	EFT	002852 PRINCIPAL FINANCIAL GROUP 1010-00-0000-22220-000000-000000	4,670.17	4,670.17		
402447	09/20/2024	EFT	004285 RENTOKIL NORTH AMERICA, I 2100-FD-FD00-54550-000000-	255.00	35.00		
	965592		2100-FD-FD00-54550-000000-		90.00		
	966269		2100-FD-FD00-54550-000000-		40.00		
	966471		2100-FD-FD00-54550-000000-		50.00		
	966294		2100-FD-FD00-54550-000000-		40.00		
402448	09/20/2024	EFT	003598 THE RESIDENCES AT CLOCKTO 2170-00-0000-57010-000000-	120,240.01	120,240.01		
	Payment 4						
402449	09/20/2024	EFT	004124 RICHARD F. CASTLE 2070-PI-PI00-53190-000000-	406.25	406.25		
	006-2024						
402450	09/20/2024	EFT	000505 RUMPKE OF OHIO INC. 1010-PK-PK00-54550-000000-	400.13	120.00		
	4046481		2100-FD-FD00-53530-000000-		68.01		
	281936		2100-FD-FD00-53530-000000-		65.76		
	0258940		2100-FD-FD00-53530-000000-		73.26		
	0359066		2100-FD-FD00-53530-000000-		73.10		
	0358153						
402451	09/20/2024	EFT	002747 RUSH TRUCK CENTERS OF OHI 2010-RD-RD00-53510-000000-	651.57	651.57		
	3038756743						
402452	09/20/2024	EFT	003323 SHRADER TIRE & OIL, INC. 2090-PD-PD00-53510-000000-	3,515.47	3,515.47		
	24-0884454-00						
402453	09/20/2024	EFT	003762 SMARTSAFETY SOFTWARE INC 2090-PD-PD00-54830-000000-	3,120.48	3,120.48		
	TLSMN0001680						
402454	09/20/2024	EFT	000761 STAPLES INC 1010-SV-SV00-54510-000000-	42.36	42.36		
	6011837344						
402455	09/20/2024	EFT	002542 SUNBELT RENTALS INC. 2040-RD-RD00-54550-IHCURB-	389.50	389.50		
	159426885-0001						
402456	09/20/2024	EFT	003909 CITY OF TRENTON	260.00			

AP CHECK RECONCILIATION REGISTER

FOR CASH ACCOUNT: 9999-00-0000-10110-000000-000000

FOR: All Except Stale

CHECK #	CHECK DATE	TYPE	VENDOR NAME	UNCLEARED	CLEARED	BATCH	CLEAR DATE
	09/14/24		2090-PD-PD00-51120-000000-		260.00		
402457	09/20/2024	EFT	003219 TRI-STATE PUBLIC SAFETY	1,679.95			
	INVOICE NO		ACCOUNT		AMOUNT		
	3986		2100-FD-FD00-53560-000000-		1,475.00		
	3978		2090-PD-PD00-57060-000000-		204.95		
402458	09/20/2024	EFT	003385 TRIAD TECHNOLOGIES, LLC.	999.16			
	62022957		2010-RD-RD00-53510-000000-		889.53		
	62023842		2010-RD-RD00-54010-000000-		109.63		
402459	09/20/2024	EFT	003340 TRIPLE S TIRE COMPANY, IN	205.00			
	143121		2010-RD-RD00-53560-000000-		205.00		
402460	09/20/2024	EFT	000583 VOGELPOHL FIRE EQUIPMENT,	5,123.26			
	4011142		2100-FD-FD00-53510-000000-		345.26		
	3008088		2100-FD-FD00-53190-000000-		4,778.00		
402461	09/20/2024	EFT	003307 MUNICIPAL EMERGENCY SERVI	114.52			
	IN2101345		2100-FD-FD00-54720-000000-		114.52		
402462	09/20/2024	EFT	001387 WHITE CAP LP	499.80			
	10020519318		2010-RD-RD00-54010-000000-		136.75		
	10020519318		2010-RD-RD00-54720-000000-		87.18		
	10020519318		2040-RD-RD00-54550-IHCURB-		275.87		
1681047	09/13/2024	PRINTED	003374 CRASHCOURSE VILLAGE INC.		3,600.00	1	09/17/2024
	24-157-Condron		2100-FD-FD00-53410-000000-		600.00		
	24-157		2100-FD-FD00-53410-000000-		3,000.00		
1681048	09/13/2024	PRINTED	003301 FABRICARE TEXTILES LLC	1,166.00			
	08/01/24-08/30/24		2090-PD-PD00-54720-000000-		945.75		
	748		2100-FD-FD00-54720-000000-		220.25		
1681049	09/13/2024	PRINTED	004024 DUKE ENERGY	837.98			
	9300 0002 4706		5070-LT-LT21-55040-000000-		837.98		
1681050	09/13/2024	PRINTED	000256 FED EX	24.52			
	8-616-96494		2070-PI-PI00-56030-AFTRHR-		24.52		
1681051	09/13/2024	PRINTED	002837 FIRST FINANCIAL BANK CRED		100.00	1	09/11/2024
	NKU Comm 8/7/24		2090-PD-PD00-53190-000000-		100.00		
1681052	09/13/2024	PRINTED	004383 FLETCHER PROJECT, THE		813.00	1	09/17/2024
	09-02-2024		2070-PI-PI00-56030-CONCRT-		813.00		
1681053	09/13/2024	PRINTED	000585 GRAINGER INC.	371.27			
	9228975091		1010-PK-PK12-53530-000000-		49.53		
	9228975109		2010-RD-RD00-54510-000000-		22.65		
	9228975109		2010-RD-RD00-54550-000000-		6.63		

AP CHECK RECONCILIATION REGISTER

FOR CASH ACCOUNT: 9999-00-0000-10110-000000-000000

FOR: All Except Stale

CHECK #	CHECK DATE	TYPE	VENDOR NAME	UNCLEARED	CLEARED	BATCH	CLEAR DATE
	9229401220		2010-RD-RD00-54510-000000-		49.27		
	INVOICE NO		ACCOUNT	AMOUNT			
	9229401220		2010-RD-RD00-54550-000000-		14.43		
	9243293330		2100-FD-FD00-54550-000000-		228.76		
1681054	09/13/2024	PRINTED	002253 JAMIE'S MULCH AND TOPSOIL	11,214.73			
	A128009		1010-PK-PK14-53530-000000-		299.74		
	A27011		5080-RD-RD00-53530-000000-		10,615.25		
	A27010		1010-PK-PK14-53530-000000-		299.74		
1681055	09/13/2024	PRINTED	004046 JUSTIN ECKSTEIN	356.21			
	Eckstein 09/09/24		2070-PI-PI00-53410-000000-		356.21		
1681056	09/13/2024	PRINTED	004050 KELLIE BYRD		50.57	1	09/16/2024
	Byrd 09/06/24		1010-AD-AD00-54530-000000-		50.57		
1681057	09/13/2024	PRINTED	004048 LISA BROWN		3,530.07	1	09/16/2024
	Brown 09/05/24		1010-AD-AD00-53410-000000-		29.00		
	Brown 09/04/24		1010-AD-AD00-56090-000000-		3,501.07		
1681058	09/13/2024	PRINTED	004118 MONICA DEXTER		291.98	1	09/16/2024
	Dexter 09/09/24		2070-PI-PI00-53410-000000-		291.98		
1681059	09/13/2024	PRINTED	004120 PATRICK EILERMAN		480.50	1	09/17/2024
	Eilerman 08/08/24		2090-PD-PD00-53410-000000-		480.50		
1681060	09/13/2024	PRINTED	004300 PERFORMANCE REDEFINE CORP	49.00			
	20240910		2100-FD-FD00-53410-000000-		49.00		
1681061	09/13/2024	PRINTED	002069 PERU'S TREE SERVICE		4,000.00	1	09/17/2024
	648		1010-PK-PK03-53530-000000-		4,000.00		
1681062	09/13/2024	PRINTED	003777 OLGA ONIPKO	20.00			
	35628		2090-PD-PD00-53190-000000-		20.00		
1681063	09/13/2024	PRINTED	003759 UNIFIRST CORPORATION	392.29			
	1340361765		1010-PK-PK00-54550-000000-		38.59		
	1340361765		1010-PK-PK00-54720-000000-		26.93		
	1340361765		1010-SV-SV99-54720-000000-		73.71		
	1340361765		2010-RD-RD00-54550-000000-		20.41		
	1340361765		2010-RD-RD00-54720-000000-		213.57		
	1340361765		2050-CE-CE00-54720-000000-		19.08		
1681064	09/13/2024	PRINTED	000600 ZIMMER TRACTOR		655.56	1	09/16/2024
	003-3031300		2010-RD-RD00-53560-000000-		655.56		
1681065	09/16/2024	PRINTED	000615 ALTAFIBER	4,559.84			
	D13-3498 Sep 24		1010-AD-AD00-55010-000000-		185.25		
	D13-3498 Sep 24		2030-RD-RD00-55010-000000-		22.75		
	D13-3498 Sep 24		2070-PI-PI00-55010-000000-		6.50		

AP CHECK RECONCILIATION REGISTER

FOR CASH ACCOUNT: 9999-00-0000-10110-000000-000000

FOR: All Except Stale

CHECK #	CHECK DATE	TYPE	VENDOR NAME	UNCLEARED	CLEARED	BATCH	CLEAR DATE
D13-3498	Sep 24		2090-PD-PD00-55010-000000-		74.75		
		INVOICE NO	ACCOUNT		AMOUNT		
D13-3498	Sep 24		2100-FD-FD00-55010-000000-		2,960.75		
860-1946	Sep 24		1010-PK-PK11-55010-000000-		97.72		
860-5544	Sep 24		2100-FD-FD00-55010-000000-		100.44		
860-9226	Sep 24		1010-PK-PK13-55010-000000-		75.65		
874-2443	Sep 24		2100-FD-FD00-55010-000000-		198.12		
116-4535	Sep 24		2090-PD-PD00-55010-000000-		90.63		
118-3476	Sep 24		1010-PK-PK04-55010-000000-		40.00		
121-4393	Sep 24		2100-FD-FD00-55010-000000-		74.98		
122-6977	Sep 24		2100-FD-FD00-55010-000000-		74.98		
127-1428	Sep 24		2100-FD-FD00-55010-000000-		98.98		
127-7424	Sep 24		2100-FD-FD00-55010-000000-		74.98		
131-2728	Sep 24		2030-RD-RD00-55010-000000-		80.63		
682-2529	Sep 24		2100-FD-FD00-55010-000000-		126.77		
779-0071	Sep 24		1010-AD-AD00-55010-000000-		175.96		
1681066	09/16/2024	PRINTED	000641 DUKE ENERGY	4,717.00			
	FRS-0051137		5070-LT-LT03-55040-000000-		4,717.00		
1681067	09/16/2024	PRINTED	001334 DUKE ENERGY	209.77			
	910117891746	Aug 24	1010-AD-AD00-55060-000000-		209.77		
1681068	09/20/2024	PRINTED	003682 ACTIVE911 INC.	317.20			
	578928		2090-PD-PD00-53170-000000-		157.50		
	587186		2090-PD-PD00-53170-000000-		159.70		
1681069	09/20/2024	PRINTED	004008 BUTLER COUNTY WATER & SEW	1,888.65			
	2000563	Sep 24	1010-AD-AD00-55030-000000-		56.78		
	2000563	Sep 24	2070-PI-PI00-55030-000000-		7.74		
	2000564	Sep 24	1010-AD-AD00-55030-000000-		22.13		
	2000564	Sep 24	2050-CE-CE00-55030-000000-		7.38		
	2000564	Sep 24	2070-PI-PI00-55030-000000-		2.89		
	2000564	Sep 24	2090-DS-DS00-55030-000000-		10.10		
	2000564	Sep 24	2100-DS-DS00-55030-000000-		10.10		
	2000564	Sep 24	2100-FD-FD00-55030-000000-		107.75		
	2002286	Sep 24	2100-FD-FD00-55030-000000-		92.00		
	2006330	Sep 24	2100-FD-FD00-55030-000000-		81.52		
	2013795	Sep 24	1010-PK-PK04-55030-000000-		44.72		
	2013796	Sep 24	1010-PK-PK04-55030-000000-		8.64		
	2014474	Sep 24	2100-FD-FD00-55030-000000-		115.87		
	2027759	Sep 24	2100-FD-FD00-55030-000000-		112.61		
	2041335	Sep 24	1010-PK-PK13-55030-000000-		40.33		
	2049236	Sep 24	1010-PK-PK11-55030-000000-		95.26		
	2051667	Sep 24	1010-PK-PK12-55030-000000-		155.35		
	2027757	Sep 24	1010-AD-AD00-55030-000000-		27.52		
	2027757	Sep 24	1010-CD-CD00-55030-000000-		18.35		
	2027757	Sep 24	2030-RD-RD00-55030-000000-		201.85		
	2027757	Sep 24	2090-PD-PD00-55030-000000-		669.76		

AP CHECK RECONCILIATION REGISTER

FOR CASH ACCOUNT: 9999-00-0000-10110-000000-000000

FOR: All Except Stale

CHECK #	CHECK DATE	TYPE	VENDOR NAME	UNCLEARED	CLEARED	BATCH	CLEAR DATE
1681070	09/20/2024	PRINTED	002799 CELLEBRITE, INC.	7,000.00			
	INVOICE NO		ACCOUNT		AMOUNT		
	INVUS275109		2090-PD-PD00-54830-000000-		7,000.00		
1681071	09/20/2024	PRINTED	004390 CHRIS SHANE COMPANY LLC 19256	1,559.20	1,559.20		
1681072	09/20/2024	PRINTED	000192 OHIO NEWSPAPERS INC 091024	513.00	513.00		
1681073	09/20/2024	PRINTED	001334 DUKE ENERGY 910134027453 Sep 24	65.61	65.61		
1681074	09/20/2024	PRINTED	000585 GRAINGER INC. 9244086766	187.22	9.06		
			1010-AD-AD00-53530-000000-		5.18		
			9244086766		62.15		
			2010-RD-RD00-53530-000000-		53.09		
			9244086766		57.74		
			2090-PD-PD00-53530-000000-				
			9237261996				
			1010-SV-SV99-54010-000000-				
1681075	09/20/2024	PRINTED	000753 GREAT AMERICAN FINANCIAL 09/20/24	470.00	470.00		
1681076	09/20/2024	PRINTED	004263 HOLLAND SUPPLY INC INV155387	1,229.77	1,229.77		
1681077	09/20/2024	PRINTED	003333 INTERNATIONAL ASSOCIATION 12926	25.00	25.00		
1681078	09/20/2024	PRINTED	000344 JACKSON CONSTRUCTION INC. 297	315,709.50	315,709.50		
1681079	09/20/2024	PRINTED	003445 KENWOOD DEALER GROUP INC 294909	400.30	400.30		
1681080	09/20/2024	PRINTED	004393 KEVIN SAMS Sams 09/12/24	91.40	91.40		
1681081	09/20/2024	PRINTED	002690 MEDMUTUAL LIFE	2,035.46			
	034449694-8		2040-RD-RD00-52220-000000-		164.66		
	034449694-8		2050-CE-CE00-52220-000000-		16.00		
	034449694-8		2090-PD-PD00-52220-000000-		747.20		
	034449694-8		2100-FD-FD00-52220-000000-		654.00		
	034449694-8		2110-EM-EM00-52220-000000-		38.00		
	034449694-8		2070-PI-PI00-52220-000000-		40.00		
	034449694-8		1010-AD-AD02-52220-000000-		18.40		
	034449694-8		1010-AD-AD03-52220-000000-		4.00		
	034449694-8		1010-CD-CD00-52220-000000-		52.00		
	034449694-8		1010-PK-PK00-52220-000000-		8.00		
	034449694-8		2090-DS-DS00-52220-000000-		83.20		

AP CHECK RECONCILIATION REGISTER

FOR CASH ACCOUNT: 9999-00-0000-10110-000000-000000

FOR: All Except Stale

CHECK #	CHECK DATE	TYPE	VENDOR NAME	UNCLEARED	CLEARED	BATCH	CLEAR DATE
	034449694-8		2100-DS-DS00-52220-000000-		44.80		
	INVOICE NO		ACCOUNT	AMOUNT			
	034449694-8		5080-RD-RD00-52220-000000-		8.00		
	034449694-8		1010-SV-SV00-52220-000000-		45.20		
	034449694-8		1010-AD-AD00-52220-000000-		112.00		
1681082	09/20/2024	PRINTED	002776 MIKE CASTRUCCI FORD INC 153671 2090-PD-PD00-53510-000000-	638.75	638.75		
1681083	09/20/2024	PRINTED	004184 OHIO CHILD SUPPORT PAYMEN 09/20/24 1010-00-0000-22010-000000-000000	2,754.10	2,754.10		
1681084	09/20/2024	PRINTED	000465 OHIO FIRE CHIEFS ASSOCIAT 76826 2100-FD-FD00-53170-000000- 76822 2100-FD-FD00-53170-000000- 79118 2100-FD-FD00-53170-000000- 76687 2100-FD-FD00-53170-000000- 78275 2100-FD-FD00-53170-000000- 78272 2100-FD-FD00-53170-000000- 78452 2100-FD-FD00-53230-000000-	6,000.00	125.00 125.00 125.00 125.00 100.00 100.00 5,300.00		
1681085	09/20/2024	PRINTED	000755 OHIO PUBLIC EMPLOYEES DEF oh Dfrd 09/20/24 1010-00-0000-22520-000000-000000	25,692.70	25,692.70		
1681086	09/20/2024	PRINTED	004300 PERFORMANCE REDEFINE CORP 20240913 2100-FD-FD00-53410-000000-	49.00	49.00		
1681087	09/20/2024	PRINTED	001882 DRELLISHAK & DRELLISHAK I INV4065 2700-PD-PD00-54720-000000-	1,086.59	1,086.59		
1681088	09/20/2024	PRINTED	001329 SECURITY BENEFIT GROUP 611021 09/20/24 1010-00-0000-22010-000000-000000 611021 09/20/24 1010-00-0000-22520-000000-000000	9,685.00	1,630.00 8,055.00		
1681089	09/20/2024	PRINTED	000535 SUBURBAN PROPANE 603857 2010-RD-RD00-54550-000000-	92.86	92.86		
1681090	09/20/2024	PRINTED	003759 UNIFIRST CORPORATION 1340364317 1010-PK-PK00-54550-000000- 1340364317 1010-PK-PK00-54720-000000- 1340364317 1010-SV-SV99-54720-000000- 1340364317 2010-RD-RD00-54550-000000- 1340364317 2010-RD-RD00-54720-000000- 1340364317 2050-CE-CE00-54720-000000-	404.08	38.59 26.93 75.29 20.41 223.78 19.08		
1681091	09/20/2024	PRINTED	000577 VERIZON WIRELESS 9973411035 1010-AD-AD00-55020-000000- 9973411035 2070-SR-SR00-55020-000000- 9973411035 2070-PI-PI00-55020-000000- 9973411035 2090-DS-DS00-55020-000000-	709.74	119.38 52.30 40.11 26.15		

AP CHECK RECONCILIATION REGISTER

FOR CASH ACCOUNT: 9999-00-0000-10110-000000-000000

FOR: All Except Stale

CHECK #	CHECK DATE	TYPE	VENDOR NAME	UNCLEARED	CLEARED	BATCH	CLEAR DATE
9973411035			2090-PD-PD00-55020-000000-		44.47		
	INVOICE NO		ACCOUNT	AMOUNT			
9973411035			2100-DS-DS00-55020-000000-		26.15		
9973411035			2100-FD-FD00-55020-000000-		401.18		
1681092	09/20/2024	PRINTED	004386 WOODLAWN IAFF LOCAL 3746	360.00			
	2024-1		2100-FD-FD00-53410-000000-		360.00		
			133 CHECKS	CASH ACCOUNT TOTAL	882,754.36	259,162.68	

AP CHECK RECONCILIATION REGISTER

		UNCLEARED	CLEARED
133 CHECKS	FINAL TOTAL	882,754.36	259,162.68

** END OF REPORT - Generated by Felicia Krutka **

AP CHECK RECONCILIATION REGISTER

FOR CASH ACCOUNT: 9999-00-0000-10110-000000-000000

FOR: All Except Stale

CHECK #	CHECK DATE	TYPE	VENDOR NAME	UNCLEARED	CLEARED	BATCH	CLEAR DATE
2415	09/20/2024	MANUAL	000900 UNITED STATES TREASURY		107,452.20	1	09/20/2024
	INVOICE NO		ACCOUNT		AMOUNT		
	09/20/24		1010-00-0000-22010-000000-000000		107,452.20		
2416	09/20/2024	MANUAL	000319 HOME DEPOT	12.50			
	7200572		1010-PK-PK04-53530-000000-		12.50		
2417	09/20/2024	MANUAL	000319 HOME DEPOT	-12.74			
	7200573		1010-PK-PK04-53530-000000-		-12.74		
2418	09/20/2024	MANUAL	000319 HOME DEPOT	11.72			
	7200574		1010-PK-PK04-53530-000000-		11.72		
2419	09/20/2024	MANUAL	000319 HOME DEPOT	25.87			
	7011253		1010-PK-PK04-53530-000000-		25.87		
2420	09/20/2024	MANUAL	000319 HOME DEPOT	-10.60			
	7200571		1010-PK-PK04-53530-000000-		-10.60		
2421	09/24/2024	MANUAL	000319 HOME DEPOT	58.33			
	5011404		2040-RD-RD00-54550-IHCURB-		58.33		
2422	09/24/2024	MANUAL	000319 HOME DEPOT	48.37			
	3011706		1010-PK-PK11-54550-000000-		12.23		
	3011706		2010-RD-RD00-54550-000000-		36.14		
2423	09/27/2024	MANUAL	003159 CHARTER COMMUNICATIONS	105.75			
	0198833 09/14/24		2090-DS-DS00-55060-000000-		52.87		
	0198833 09/14/24		2100-DS-DS00-55060-000000-		52.88		
2424	09/25/2024	MANUAL	000319 HOME DEPOT	97.98			
	4011627		2100-FD-FD00-54010-000000-		97.98		
2425	09/25/2024	MANUAL	000780 LOWES	72.76			
	979992		2100-FD-FD00-53410-000000-		72.76		
402417	09/20/2024	EFT	001532 A-PLUS CONCRETE & EXCAVAT		32.00	1	09/20/2024
	12353		1010-PK-PK04-53530-000000-		32.00		
402418	09/20/2024	EFT	003800 ADW ACQUISITIONS LLC		156.28	1	09/20/2024
	18180717		2110-EM-EM00-53510-000000-		156.28		
402419	09/20/2024	EFT	000016 AERO OIL COMPANY OF CINCI		877.25	1	09/20/2024
	190486		2010-RD-RD00-53510-000000-		438.63		
	190486		2100-FD-FD00-53510-000000-		219.31		
	190486		2110-EM-EM00-53510-000000-		219.31		
402420	09/20/2024	EFT	002469 AFLAC GROUP INSURANCE - G		1,436.43	1	09/20/2024
	WCTWP-9325 Sep 2024		1010-00-0000-22220-000000-000000		1,436.43		

AP CHECK RECONCILIATION REGISTER

FOR CASH ACCOUNT: 9999-00-0000-10110-000000-000000

FOR: All Except Stale

CHECK #	CHECK DATE	TYPE	VENDOR NAME	UNCLEARED	CLEARED	BATCH	CLEAR DATE
402421	09/20/2024	EFT	002422 AFSCME OHIO COUNCIL 8, LO		497.70	1	09/20/2024
	INVOICE NO		ACCOUNT		AMOUNT		
	09/20/24	Union Dues	1010-00-0000-22510-000000-000000		497.70		
402422	09/20/2024	EFT	003337 AIRGAS, INC.		370.99	1	09/20/2024
	5510333027		2010-RD-RD00-53550-000000-		57.28		
	5510324085		2110-EM-EM00-54550-000000-		313.71		
402423	09/20/2024	EFT	002035 AL-JOE'S INC		239.98	1	09/20/2024
	1060931		2010-RD-RD00-54010-000000-		239.98		
402424	09/20/2024	EFT	003174 AMAZON FULLFILLMENT SERVI		998.38	1	09/20/2024
	1MKF-KXWP-13MG		1010-PK-PK11-53530-000000-		37.58		
	1MKF-KXWP-13MG		1010-SV-SV00-54510-000000-		48.99		
	1D1H-WMPY-1GQR		2010-RD-RD00-54720-000000-		229.98		
	1PNT-DGLQ-C7CD		1010-PK-PK04-53530-000000-		33.54		
	1PNT-DGLQ-C7CD		1010-SV-SV00-54510-000000-		10.99		
	1W64-9TMX-PTCT		2100-FD-FD00-54010-000000-		38.61		
	1QNY-1TYX-WYR4		1010-PK-PK10-54550-000000-		13.99		
	1QNY-1TYX-WYR4		1010-SV-SV00-54510-000000-		121.58		
	1QNY-1TYX-WYR4		2010-RD-RD00-53560-000000-		139.95		
	1QNY-1TYX-WYR4		2010-RD-RD00-54010-000000-		222.53		
	1NQ3-7D9P-GV1M		2100-FD-FD00-54510-000000-		41.12		
	17GM-MKFG-HXH7		1010-AD-AD00-54510-000000-		68.97		
	1KJ7-4QQH-7MYT		1010-AD-AD00-54510-000000-		301.06		
	1VLM-PY4P-3KV1		2090-PD-PD00-54010-000000-		-310.51		
402425	09/20/2024	EFT	000117 BETHESDA HEALTHCARE INC.		3,116.00	1	09/20/2024
	6280-493206		2100-FD-FD00-53190-000000-		3,116.00		
402426	09/20/2024	EFT	000126 BOUND TREE MEDICAL LLC.		2,279.86	1	09/20/2024
	85392054		2110-EM-EM00-54550-000000-		654.50		
	85469487		2110-EM-EM00-54550-000000-		1,118.96		
	85485408		2110-EM-EM00-54550-000000-		506.40		
402427	09/20/2024	EFT	001346 CAPITAL ELECTRIC LINE BUI		639.05	1	09/20/2024
	92103		2100-FD-FD00-54550-000000-		639.05		
402428	09/20/2024	EFT	003558 CENTRALSQUARE TECHNOLOGIE		9,200.10	1	09/20/2024
	418077		2090-PD-PD00-54820-000000-		4,600.05		
	418077		2100-FD-FD00-54820-000000-		2,300.03		
	418077		2110-EM-EM00-54820-000000-		2,300.02		
402429	09/20/2024	EFT	004391 CINCY COMPANY LLC		3,750.00	1	09/20/2024
	0563465		2070-PI-PI00-53720-000000-		3,750.00		
402430	09/20/2024	EFT	004326 CLINTON COUNTY MOTORSPORT		47,738.97	1	09/20/2024
	290005		2100-FD-FD00-57060-000000-		47,738.97		
402431	09/20/2024	EFT	004227 EMPOWER RETIREMENT LLC		1,595.00	1	09/20/2024

AP CHECK RECONCILIATION REGISTER

FOR CASH ACCOUNT: 9999-00-0000-10110-000000-000000

FOR: All Except Stale

CHECK #	CHECK DATE	TYPE	VENDOR NAME	UNCLEARED	CLEARED	BATCH	CLEAR DATE
	09/20/24		1010-00-0000-22010-000000-000000		530.00		
	INVOICE NO		ACCOUNT	AMOUNT			
	09/20/24		1010-00-0000-22520-000000-000000		1,065.00		
402432	09/20/2024	EFT	003763 THE FECHHEIMER BROTHERS C		1,132.33	1	09/20/2024
	000421184		2700-PD-PD00-54720-000000-		766.22		
	000422837		2090-PD-PD00-54720-000000-		366.11		
402433	09/20/2024	EFT	003450 FERGUSON US HOLDINGS INC		268.70	1	09/20/2024
	0916350		1010-PK-PK12-53530-000000-		153.49		
	0915472		1010-PK-PK12-53530-000000-		115.21		
402434	09/20/2024	EFT	003236 FIRST RESPONDER OUTFITTER		1,071.00	1	09/20/2024
	9367-3		2700-PD-PD00-54720-000000-		535.50		
	9292-3		2090-PD-PD00-54720-000000-		535.50		
402435	09/20/2024	EFT	000754 F.O.P. LODGE #186		2,025.00	1	09/20/2024
	FOP 186 09/20/24		1010-00-0000-22510-000000-000000		2,025.00		
402436	09/20/2024	EFT	002442 FOX TOWING INC.		350.00	1	09/20/2024
	253002		2090-PD-PD00-53240-000000-		350.00		
402437	09/20/2024	EFT	000277 GALLS, LLC		5,841.91	1	09/20/2024
	029051394		2090-PD-PD00-54720-000000-		22.43		
	028752316		2100-FD-FD00-54720-000000-		260.45		
	028619275		2100-FD-FD00-54720-000000-		168.95		
	028658545		2100-FD-FD00-54720-000000-		505.86		
	028595556		2100-FD-FD00-54720-000000-		142.99		
	028781786		2100-FD-FD00-54720-000000-		118.04		
	028771273		2100-FD-FD00-54720-000000-		105.95		
	028632007		2100-FD-FD00-54720-000000-		170.50		
	028659868		2100-FD-FD00-54720-000000-		17.04		
	028623959		2100-FD-FD00-54720-000000-		23.34		
	028632289		2100-FD-FD00-54720-000000-		156.55		
	028594516		2100-FD-FD00-54720-000000-		146.21		
	028573580		2100-FD-FD00-54720-000000-		173.00		
	028605500		2100-FD-FD00-54720-000000-		290.18		
	028775554		2100-FD-FD00-54720-000000-		478.40		
	028593373		2100-FD-FD00-54720-000000-		160.83		
	028582194		2100-FD-FD00-54720-000000-		233.82		
	028574014		2100-FD-FD00-54720-000000-		60.26		
	028565408		2100-FD-FD00-54720-000000-		21.00		
	028682360		2100-FD-FD00-54720-000000-		70.42		
	028739421		2100-FD-FD00-54720-000000-		132.41		
	028670369		2100-FD-FD00-54720-000000-		260.23		
	028776757		2100-FD-FD00-54720-000000-		500.07		
	028615183		2100-FD-FD00-54720-000000-		70.70		
	028583948		2100-FD-FD00-54720-000000-		110.00		
	028605505		2100-FD-FD00-54720-000000-		145.87		
	028701557		2100-FD-FD00-54720-000000-		268.51		

AP CHECK RECONCILIATION REGISTER

FOR CASH ACCOUNT: 9999-00-0000-10110-000000-000000

FOR: All Except Stale

CHECK #	CHECK DATE	TYPE	VENDOR NAME	UNCLEARED	CLEARED	BATCH	CLEAR DATE
	028811942		2100-FD-FD00-54720-000000-		205.86		
	INVOICE NO		ACCOUNT	AMOUNT			
	028626509		2100-FD-FD00-54720-000000-		70.34		
	028593415		2100-FD-FD00-54720-000000-		146.82		
	028694726		2100-FD-FD00-54720-000000-		204.46		
	028603905		2100-FD-FD00-54720-000000-		303.66		
	028593385		2100-FD-FD00-54720-000000-		73.41		
	028623966		2100-FD-FD00-54720-000000-		23.35		
402438	09/20/2024	EFT	003047 ROQUEMORE ENTERPRISES INC 2021-5658		6,565.00 6,565.00	1	09/20/2024
402439	09/20/2024	EFT	003235 MAGNET FORENSICS USA, INC SIN072409		2,710.00 2,710.00	1	09/20/2024
402440	09/20/2024	EFT	003779 IMPERIAL BAG & PAPER CO L 35354013 35354013		1,137.57 1,110.69 26.88	1	09/20/2024
402441	09/20/2024	EFT	000410 MCGILL SMITH PUNSHON INC. 50583		14,632.34 14,632.34	1	09/20/2024
402442	09/20/2024	EFT	000424 MIAMI UNIVERSITY VOACMF 2024 A		240.00 240.00	1	09/20/2024
402443	09/20/2024	EFT	000442 MOTOROLA SOLUTIONS, INC. 8281974618		3,197.20 3,197.20	1	09/20/2024
402444	09/20/2024	EFT	003478 O'REILLY AUTO ENTERPRISES 1738-392334 1738-392618 1738-392372 1738-391950 1738-391711 1738-391676 1738-390838 1738-391937 1738-393913 1738-391949 1738-391966 1738-391966B		1,353.03 316.90 201.15 -44.00 42.28 100.25 625.02 123.66 46.53 34.30 -46.53 -17.64 -28.89	1	09/20/2024
402445	09/20/2024	EFT	003439 PENN CARE INC M118875		777.60 777.60	1	09/20/2024
402446	09/20/2024	EFT	002852 PRINCIPAL FINANCIAL GROUP 1040669 Oct 2024		4,670.17 4,670.17	1	09/20/2024
402447	09/20/2024	EFT	004285 RENTOKIL NORTH AMERICA, I 965592		255.00 35.00	1	09/20/2024

AP CHECK RECONCILIATION REGISTER

FOR CASH ACCOUNT: 9999-00-0000-10110-000000-000000

FOR: All Except Stale

CHECK #	CHECK DATE	TYPE	VENDOR NAME	UNCLEARED	CLEARED	BATCH	CLEAR DATE
	966269		2100-FD-FD00-54550-000000-		90.00		
	INVOICE NO		ACCOUNT	AMOUNT			
	966471		2100-FD-FD00-54550-000000-		40.00		
	966294		2100-FD-FD00-54550-000000-		50.00		
	966297		2100-FD-FD00-54550-000000-		40.00		
402448	09/20/2024	EFT	003598 THE RESIDENCES AT CLOCKTO		120,240.01	1	09/20/2024
	Payment 4		2170-00-0000-57010-000000-		120,240.01		
402449	09/20/2024	EFT	004124 RICHARD F. CASTLE		406.25	1	09/20/2024
	006-2024		2070-PI-PI00-53190-000000-		406.25		
402450	09/20/2024	EFT	000505 RUMPKE OF OHIO INC.		400.13	1	09/20/2024
	4046481		1010-PK-PK00-54550-000000-		120.00		
	281936		2100-FD-FD00-53530-000000-		68.01		
	0258940		2100-FD-FD00-53530-000000-		65.76		
	0359066		2100-FD-FD00-53530-000000-		73.26		
	0358153		2100-FD-FD00-53530-000000-		73.10		
402451	09/20/2024	EFT	002747 RUSH TRUCK CENTERS OF OHI		651.57	1	09/20/2024
	3038756743		2010-RD-RD00-53510-000000-		651.57		
402452	09/20/2024	EFT	003323 SHRADER TIRE & OIL, INC.		3,515.47	1	09/20/2024
	24-0884454-00		2090-PD-PD00-53510-000000-		3,515.47		
402453	09/20/2024	EFT	003762 SMARTSAFETY SOFTWARE INC		3,120.48	1	09/20/2024
	TLSMN0001680		2090-PD-PD00-54830-000000-		3,120.48		
402454	09/20/2024	EFT	000761 STAPLES INC		42.36	1	09/20/2024
	6011837344		1010-SV-SV00-54510-000000-		42.36		
402455	09/20/2024	EFT	002542 SUNBELT RENTALS INC.		389.50	1	09/20/2024
	159426885-0001		2040-RD-RD00-54550-IHCURB-		389.50		
402456	09/20/2024	EFT	003909 CITY OF TRENTON		260.00	1	09/20/2024
	09/14/24		2090-PD-PD00-51120-000000-		260.00		
402457	09/20/2024	EFT	003219 TRI-STATE PUBLIC SAFETY		1,679.95	1	09/20/2024
	3986		2100-FD-FD00-53560-000000-		1,475.00		
	3978		2090-PD-PD00-57060-000000-		204.95		
402458	09/20/2024	EFT	003385 TRIAD TECHNOLOGIES, LLC.		999.16	1	09/20/2024
	62022957		2010-RD-RD00-53510-000000-		889.53		
	62023842		2010-RD-RD00-54010-000000-		109.63		
402459	09/20/2024	EFT	003340 TRIPLE S TIRE COMPANY, IN		205.00	1	09/20/2024
	143121		2010-RD-RD00-53560-000000-		205.00		
402460	09/20/2024	EFT	000583 VOGELPOHL FIRE EQUIPMENT,		5,123.26	1	09/20/2024
	4011142		2100-FD-FD00-53510-000000-		345.26		

AP CHECK RECONCILIATION REGISTER

FOR CASH ACCOUNT: 9999-00-0000-10110-000000-000000

FOR: All Except Stale

CHECK #	CHECK DATE	TYPE	VENDOR NAME	UNCLEARED	CLEARED	BATCH	CLEAR DATE
	3008088		2100-FD-FD00-53190-000000-		4,778.00		
402461	09/20/2024	EFT	003307 MUNICIPAL EMERGENCY SERVI		114.52	1	09/20/2024
	INVOICE NO		ACCOUNT		AMOUNT		
	IN2101345		2100-FD-FD00-54720-000000-		114.52		
402462	09/20/2024	EFT	001387 WHITE CAP LP		499.80	1	09/20/2024
	10020519318		2010-RD-RD00-54010-000000-		136.75		
	10020519318		2010-RD-RD00-54720-000000-		87.18		
	10020519318		2040-RD-RD00-54550-IHCURB-		275.87		
402463	09/27/2024	EFT	001532 A-PLUS CONCRETE & EXCAVAT	128.00			
	12403		2040-RD-RD00-54550-IHCURB-		128.00		
402464	09/27/2024	EFT	000008 ACE HARDWARE W.C. INC.	23.55			
	37087/1		2040-RD-RD00-54550-IHCLVT-		23.55		
402465	09/27/2024	EFT	000019 AETNA	437,808.61			
	J1844429		1010-00-0000-22210-000000-000000		418,385.15		
	J1844429		1010-00-0000-22230-000000-000000		17,190.15		
	J1844429		1010-00-0000-22270-000000-000000		2,233.31		
402466	09/27/2024	EFT	003174 AMAZON FULLFILLMENT SERVI	1,064.18			
	13QQ-17P4-CP9M		1010-SV-SV00-54510-000000-		109.32		
	133W-4WWT-46Y6		2090-PD-PD00-53170-000000-		133.23		
	1KGT-7PDX-LJV7		2090-PD-PD00-54510-000000-		278.62		
	1HXY-CGVF-D3XF		2010-RD-RD00-54010-000000-		55.95		
	1HXY-CGVF-D3XF		2010-RD-RD01-54550-000000-		11.99		
	1PQN-PGMK-FFF6		1010-PK-PK04-53530-000000-		100.00		
	1PQN-PGMK-FFF6		2010-RD-RD00-54010-000000-		57.19		
	11LK11LK-VWLM-D7DR		1010-AD-AD00-53190-000000-		317.88		
402467	09/27/2024	EFT	004156 ARC DOCUMENT SOLUTIONS LL	535.95			
	210HI9322140		1010-CD-CD00-53560-000000-		535.95		
402468	09/27/2024	EFT	004122 BACHMAN'S INC	13,370.00			
	J000845		2100-FD-FD00-57050-000000-		13,370.00		
402469	09/27/2024	EFT	000117 BETHESDA HEALTHCARE INC.	720.00			
	6280-496349		2100-FD-FD00-53190-000000-		720.00		
402470	09/27/2024	EFT	001471 CDW GOVERNMENT INC.	340.05			
	RC60366		2090-DS-DS00-54010-000000-		170.03		
	RC60366		2100-DS-DS00-54010-000000-		170.02		
402471	09/27/2024	EFT	000192 OHIO NEWSPAPERS INC	359.10			
	I00844751-09012024		1010-AD-AD00-53720-000000-		171.00		
	I00844248		1010-CD-CD00-53720-000000-		188.10		
402472	09/27/2024	EFT	000202 CUMMINS BRIDGEWAY LLC	9,211.77			

AP CHECK RECONCILIATION REGISTER

FOR CASH ACCOUNT: 9999-00-0000-10110-000000-000000

FOR: All Except Stale

CHECK #	CHECK DATE	TYPE	VENDOR NAME	UNCLEARED	CLEARED	BATCH	CLEAR DATE
	T5-31580		2100-FD-FD00-53510-000000-		6,193.04		
	INVOICE NO		ACCOUNT	AMOUNT			
	T5-31582		2100-FD-FD00-53510-000000-		3,018.73		
402473	09/27/2024	EFT	000218 DELL MARKETING L.P. 1010-AD-AD00-54810-000000-	1,855.46	1,855.46		
402474	09/27/2024	EFT	002936 DOCUMENT DESTRUCTION 1010-AD-AD00-53190-000000- 2090-DS-DS00-53190-000000- 192856 2100-DS-DS00-53190-000000- 192856 2100-FD-FD00-53190-000000-	78.25	38.35 10.17 10.17 19.56		
402475	09/27/2024	EFT	000148 FINN ALL SEASONS 2010-RD-RD00-54550-000000-	357.60	357.60		
402476	09/27/2024	EFT	002825 FIRST CHOICE COFFEE SERVI 2090-PD-PD00-54530-000000- 2090-PD-PD00-54540-000000- 391196 2010-RD-RD00-54530-000000- 391191 1010-CD-CD00-54540-000000-	618.62	250.07 85.04 140.19 143.32		
402477	09/27/2024	EFT	002442 FOX TOWING INC. 2090-PD-PD00-53240-000000-	190.00	190.00		
402478	09/27/2024	EFT	000273 FROST BROWN TODD LLC 210480402B 2090-PD-PD00-53110-000000- 210480415B 1010-AD-AD00-53110-000000- 210480396B 2090-PD-PD00-53110-000000- 210486601 1010-AD-AD00-53110-000000- 210486601 2010-RD-RD00-53110-000000- 210486601 2070-PI-PI00-53110-000000- 210486601 2090-DS-DS00-53110-000000- 210486601 2100-DS-DS00-53110-000000- 210486601 2100-FD-FD00-53110-000000- 210486601 2180-00-0000-53110-000000-	60,835.65	379.30 4,052.00 4,458.00 45,544.35 1,782.00 1,270.50 1,138.50 1,138.50 115.50 957.00		
402479	09/27/2024	EFT	002215 G & G FITNESS 1010-SV-SV00-53560-000000-	183.00	183.00		
402480	09/27/2024	EFT	000277 GALLS, LLC 2090-PD-PD00-54720-000000-	377.51	377.51		
402481	09/27/2024	EFT	000280 GATEWAY TIRE COMPANY INC. 30-0785915 2010-RD-RD00-53510-000000- 30-0766222 2050-CE-CE00-53510-000000- 30-0770152 1010-PK-PK00-53510-000000- 30-0789525 1010-PK-PK00-53560-000000-	1,793.20	281.56 759.08 523.32 229.24		
402482	09/27/2024	EFT	001128 NATIONAL ACADEMIES OF EME	975.00			

AP CHECK RECONCILIATION REGISTER

FOR CASH ACCOUNT: 9999-00-0000-10110-000000-000000

FOR: All Except Stale

CHECK #	CHECK DATE	TYPE	VENDOR NAME	UNCLEARED	CLEARED	BATCH	CLEAR DATE
	SIN365200		2090-DS-DS00-53410-000000-		212.50		
	INVOICE NO		ACCOUNT	AMOUNT			
	SIN365200		2100-DS-DS00-53410-000000-		212.50		
	sin335071		2090-DS-DS00-53190-000000-		275.00		
	sin335071		2100-DS-DS00-53190-000000-		275.00		
402483	09/27/2024	EFT	001216 KNOX ASSOCIATES	721.00			
	INV-KA-303072		2100-FD-FD00-54550-000000-		721.00		
402484	09/27/2024	EFT	001462 LANGUAGE LINE SERVICES	506.96			
	11379531		2090-DS-DS00-53190-000000-		253.48		
	11379531		2100-DS-DS00-53190-000000-		253.48		
402485	09/27/2024	EFT	000410 MCGILL SMITH PUNSHON INC.	28,091.32			
	50699		2170-00-0000-57010-000000-		28,091.32		
402486	09/27/2024	EFT	000428 MICRO CENTER	187.97			
	12418773		2090-DS-DS00-54010-000000-		93.99		
	12418773		2100-DS-DS00-54010-000000-		93.98		
402487	09/27/2024	EFT	000442 MOTOROLA SOLUTIONS, INC.	14,488.52			
	8281972118		2100-FD-FD00-57060-000000-		14,488.52		
402488	09/27/2024	EFT	000604 NORTHCOAST PRODUCTS	820.00			
	13630		2040-RD-RD00-54550-IHCRCK-		820.00		
402489	09/27/2024	EFT	003478 O'REILLY AUTO ENTERPRISES	59.53			
	1738-395981		2090-PD-PD00-53510-000000-		10.57		
	1738-395998		2090-PD-PD00-53510-000000-		48.96		
402490	09/27/2024	EFT	004365 OTT EQUIPMENT SERVICE INC	2,725.73			
	47803		2010-RD-RD00-53560-000000-		2,725.73		
402491	09/27/2024	EFT	000475 OVERHEAD DOOR OF CINCINNA	1,899.79			
	17506519		2100-FD-FD00-53530-000000-		1,628.04		
	17391552		2100-FD-FD00-53530-000000-		271.75		
402492	09/27/2024	EFT	003439 PENN CARE INC	240.00			
	M119521		2110-EM-EM00-54550-000000-		240.00		
402493	09/27/2024	EFT	004285 RENTOKIL NORTH AMERICA, I	35.00			
	966330		2100-FD-FD00-54550-000000-		35.00		
402494	09/27/2024	EFT	000505 RUMPKE OF OHIO INC.	627.36			
	0091222		2010-RD-RD00-55060-000000-		627.36		
402495	09/27/2024	EFT	000508 SAFETY SHOE DISTRIBUTORS	604.94			
	I200-21096035		1010-SV-SV99-54720-000000-		239.98		
	I200-21096034		2010-RD-RD00-54720-000000-		116.99		
	I200-21095481		1010-SV-SV99-54720-000000-		247.97		

AP CHECK RECONCILIATION REGISTER

FOR CASH ACCOUNT: 9999-00-0000-10110-000000-000000

FOR: All Except Stale

CHECK #	CHECK DATE	TYPE	VENDOR NAME	UNCLEARED	CLEARED	BATCH	CLEAR DATE
402496	09/27/2024	EFT	000800 SIGNS BY TOMORROW	211.71			
			INVOICE NO	ACCOUNT	AMOUNT		
			23223	2070-PI-PI00-53710-000000-	211.71		
402497	09/27/2024	EFT	002453 SORA'S TOWING INC.	200.00	200.00		
			346815 2090-PD-PD00-53240-000000-				
402498	09/27/2024	EFT	003228 SMYRNA READY MIX CONCRETE	465.00	465.00		
			1020571513 2040-RD-RD00-54550-IHCURB-				
402499	09/27/2024	EFT	000761 STAPLES INC	185.34	92.67		
			6010667069 2090-DS-DS00-54510-000000-		92.67		
			6010667069 2100-DS-DS00-54510-000000-				
402500	09/27/2024	EFT	002005 THE THAMAN RUBBER CO., INC	178.29	178.29		
			w2000 0404299 1010-PK-PK12-54550-000000-				
402501	09/27/2024	EFT	003189 OUTDOOR HOME SERVICES HOL	310.89	138.44		
			200068209 2100-FD-FD00-53530-000000-		60.91		
			200086784 2100-FD-FD00-53530-000000-		111.54		
			200494764 5080-RD-RD00-54550-000000-				
402502	09/27/2024	EFT	002367 UNITED REFRIGERATION, INC	562.50	281.25		
			98388494-00 2090-DS-DS00-53530-000000-		281.25		
			98388494-00 2100-DS-DS00-53530-000000-				
402503	09/27/2024	EFT	000573 VALLEY ASPHALT CORPORATIO	164.20	114.70		
			146855 2040-RD-RD00-54550-IHPAVE-		49.50		
			147276 2040-RD-RD00-54550-IHPAVE-				
402504	09/27/2024	EFT	000583 VOGELPOHL FIRE EQUIPMENT,	3,892.41	400.52		
			6003677 2100-FD-FD00-53560-000000-		3,400.74		
			6003646 2100-FD-FD00-53510-000000-		91.15		
			4011536 2100-FD-FD00-53560-000000-				
402505	09/27/2024	EFT	003659 XAVIER UNIVERSITY	5,500.00	314.29		
			x1c4589 1010-AD-AD00-53410-000000-		157.14		
			x1c4589 1010-CD-CD00-53410-000000-		785.71		
			x1c4589 1010-SV-SV00-53410-000000-		78.57		
			x1c4589 2070-PI-PI00-53410-000000-		196.43		
			x1c4589 2090-DS-DS00-53410-000000-		1,885.71		
			x1c4589 2090-PD-PD00-53410-000000-		196.43		
			x1c4589 2100-DS-DS00-53410-000000-		1,885.72		
			x1c4589 2100-FD-FD00-53410-000000-				
1681068	09/20/2024	PRINTED	003682 ACTIVE911 INC.	317.20	157.50		
			578928 2090-PD-PD00-53170-000000-		159.70		
			587186 2090-PD-PD00-53170-000000-				

AP CHECK RECONCILIATION REGISTER

FOR CASH ACCOUNT: 9999-00-0000-10110-000000-000000

FOR: All Except Stale

CHECK #	CHECK DATE	TYPE	VENDOR NAME	UNCLEARED	CLEARED	BATCH	CLEAR DATE
1681069	09/20/2024	PRINTED	004008 BUTLER COUNTY WATER & SEW	1,888.65			
	INVOICE NO		ACCOUNT		AMOUNT		
	2000563 Sep 24		1010-AD-AD00-55030-000000-		56.78		
	2000563 Sep 24		2070-PI-PI00-55030-000000-		7.74		
	2000564 Sep 24		1010-AD-AD00-55030-000000-		22.13		
	2000564 Sep 24		2050-CE-CE00-55030-000000-		7.38		
	2000564 Sep 24		2070-PI-PI00-55030-000000-		2.89		
	2000564 Sep 24		2090-DS-DS00-55030-000000-		10.10		
	2000564 Sep 24		2100-DS-DS00-55030-000000-		10.10		
	2000564 Sep 24		2100-FD-FD00-55030-000000-		107.75		
	2002286 Sep 24		2100-FD-FD00-55030-000000-		92.00		
	2006330 Sep 24		2100-FD-FD00-55030-000000-		81.52		
	2013795 Sep 24		1010-PK-PK04-55030-000000-		44.72		
	2013796 Sep 24		1010-PK-PK04-55030-000000-		8.64		
	2014474 Sep 24		2100-FD-FD00-55030-000000-		115.87		
	2027759 Sep 24		2100-FD-FD00-55030-000000-		112.61		
	2041335 Sep 24		1010-PK-PK13-55030-000000-		40.33		
	2049236 Sep 24		1010-PK-PK11-55030-000000-		95.26		
	2051667 Sep 24		1010-PK-PK12-55030-000000-		155.35		
	2027757 Sep 24		1010-AD-AD00-55030-000000-		27.52		
	2027757 Sep 24		1010-CD-CD00-55030-000000-		18.35		
	2027757 Sep 24		2030-RD-RD00-55030-000000-		201.85		
	2027757 Sep 24		2090-PD-PD00-55030-000000-		669.76		
1681070	09/20/2024	PRINTED	002799 CELLEBRITE, INC.		7,000.00		
	INVUS275109		2090-PD-PD00-54830-000000-		7,000.00	1	09/25/2024
1681071	09/20/2024	PRINTED	004390 CHRIS SHANE COMPANY LLC		1,559.20		
	19256		1010-PK-PK04-53530-000000-		1,559.20	1	09/24/2024
1681072	09/20/2024	PRINTED	000192 OHIO NEWSPAPERS INC		513.00		
	091024		1010-AD-AD00-53720-000000-		513.00	1	09/24/2024
1681073	09/20/2024	PRINTED	001334 DUKE ENERGY		65.61		
	910134027453 Sep 24		1010-LT-LT00-55040-000000-		65.61	1	09/25/2024
1681074	09/20/2024	PRINTED	000585 GRAINGER INC.		187.22		
	9244086766		1010-AD-AD00-53530-000000-		9.06	1	09/25/2024
	9244086766		1010-CD-CD00-53530-000000-		5.18		
	9244086766		2010-RD-RD00-53530-000000-		62.15		
	9244086766		2090-PD-PD00-53530-000000-		53.09		
	9237261996		1010-SV-SV99-54010-000000-		57.74		
1681075	09/20/2024	PRINTED	000753 GREAT AMERICAN FINANCIAL	470.00			
	09/20/24		1010-00-0000-22010-000000-000000		470.00		
1681076	09/20/2024	PRINTED	004263 HOLLAND SUPPLY INC	1,229.77			
	INV155387		2050-CE-CE00-54010-000000-		1,229.77		
1681077	09/20/2024	PRINTED	003333 INTERNATIONAL ASSOCIATION	25.00			

AP CHECK RECONCILIATION REGISTER

FOR CASH ACCOUNT: 9999-00-0000-10110-000000-000000

FOR: All Except Stale

CHECK #	CHECK DATE	TYPE	VENDOR NAME	UNCLEARED	CLEARED	BATCH	CLEAR DATE
	12926		2090-PD-PD00-53170-000000-		25.00		
1681078	09/20/2024	PRINTED	000344 JACKSON CONSTRUCTION INC.		315,709.50	1	09/20/2024
	INVOICE NO		ACCOUNT		AMOUNT		
	297		2040-RD-RD00-57070-RCURBS-		315,709.50		
1681079	09/20/2024	PRINTED	003445 KENWOOD DEALER GROUP INC 294909	400.30	400.30		
1681080	09/20/2024	PRINTED	004393 KEVIN SAMS Sams 09/12/24		91.40 91.40	1	09/24/2024
1681081	09/20/2024	PRINTED	002690 MEDMUTUAL LIFE		2,035.46	1	09/24/2024
	034449694-8		2040-RD-RD00-52220-000000-		164.66		
	034449694-8		2050-CE-CE00-52220-000000-		16.00		
	034449694-8		2090-PD-PD00-52220-000000-		747.20		
	034449694-8		2100-FD-FD00-52220-000000-		654.00		
	034449694-8		2110-EM-EM00-52220-000000-		38.00		
	034449694-8		2070-PI-PI00-52220-000000-		40.00		
	034449694-8		1010-AD-AD02-52220-000000-		18.40		
	034449694-8		1010-AD-AD03-52220-000000-		4.00		
	034449694-8		1010-CD-CD00-52220-000000-		52.00		
	034449694-8		1010-PK-PK00-52220-000000-		8.00		
	034449694-8		2090-DS-DS00-52220-000000-		83.20		
	034449694-8		2100-DS-DS00-52220-000000-		44.80		
	034449694-8		5080-RD-RD00-52220-000000-		8.00		
	034449694-8		1010-SV-SV00-52220-000000-		45.20		
	034449694-8		1010-AD-AD00-52220-000000-		112.00		
1681082	09/20/2024	PRINTED	002776 MIKE CASTRUCCI FORD INC 153671	638.75	638.75		
1681083	09/20/2024	PRINTED	004184 OHIO CHILD SUPPORT PAYMEN 09/20/24		2,754.10 2,754.10	1	09/24/2024
1681084	09/20/2024	PRINTED	000465 OHIO FIRE CHIEFS ASSOCIAT	6,000.00			
	76826		2100-FD-FD00-53170-000000-		125.00		
	76822		2100-FD-FD00-53170-000000-		125.00		
	79118		2100-FD-FD00-53170-000000-		125.00		
	76687		2100-FD-FD00-53170-000000-		125.00		
	78275		2100-FD-FD00-53170-000000-		100.00		
	78272		2100-FD-FD00-53170-000000-		100.00		
	78452		2100-FD-FD00-53230-000000-		5,300.00		
1681085	09/20/2024	PRINTED	000755 OHIO PUBLIC EMPLOYEES DEF oh dfrd 09/20/24		25,692.70 25,692.70	1	09/25/2024
1681086	09/20/2024	PRINTED	004300 PERFORMANCE REDEFINE CORP 20240913	49.00	49.00		

AP CHECK RECONCILIATION REGISTER

FOR CASH ACCOUNT: 9999-00-0000-10110-000000-000000

FOR: All Except Stale

CHECK #	CHECK DATE	TYPE	VENDOR NAME	UNCLEARED	CLEARED	BATCH	CLEAR DATE
1681087	09/20/2024	PRINTED	001882 DRELLISHAK & DRELLISHAK I		1,086.59	1	09/24/2024
		INVOICE NO	ACCOUNT	AMOUNT			
		INV4065	2700-PD-PD00-54720-000000-		1,086.59		
1681088	09/20/2024	PRINTED	001329 SECURITY BENEFIT GROUP		9,685.00	1	09/25/2024
	611021 09/20/24		1010-00-0000-22010-000000-000000		1,630.00		
	611021 09/20/24		1010-00-0000-22520-000000-000000		8,055.00		
1681089	09/20/2024	PRINTED	000535 SUBURBAN PROPANE	92.86			
	603857		2010-RD-RD00-54550-000000-		92.86		
1681090	09/20/2024	PRINTED	003759 UNIFIRST CORPORATION		404.08	1	09/25/2024
	1340364317		1010-PK-PK00-54550-000000-		38.59		
	1340364317		1010-PK-PK00-54720-000000-		26.93		
	1340364317		1010-SV-SV99-54720-000000-		75.29		
	1340364317		2010-RD-RD00-54550-000000-		20.41		
	1340364317		2010-RD-RD00-54720-000000-		223.78		
	1340364317		2050-CE-CE00-54720-000000-		19.08		
1681091	09/20/2024	PRINTED	000577 VERIZON WIRELESS		709.74	1	09/25/2024
	9973411035		1010-AD-AD00-55020-000000-		119.38		
	9973411035		2070-SR-SR00-55020-000000-		52.30		
	9973411035		2070-PI-PI00-55020-000000-		40.11		
	9973411035		2090-DS-DS00-55020-000000-		26.15		
	9973411035		2090-PD-PD00-55020-000000-		44.47		
	9973411035		2100-DS-DS00-55020-000000-		26.15		
	9973411035		2100-FD-FD00-55020-000000-		401.18		
1681092	09/20/2024	PRINTED	004386 WOODLAWN IAFF LOCAL 3746	360.00			
	2024-1		2100-FD-FD00-53410-000000-		360.00		
1681093	09/27/2024	PRINTED	003736 ALLGEIER & SON INC	26,823.00			
	43137		1010-CD-CD00-53210-000000-		26,823.00		
1681094	09/27/2024	PRINTED	000615 ALTA FIBER	452.29			
	755-3764 Oct 24		2090-PD-PD00-55010-000000-		175.83		
	755-3764 Oct 24		2100-FD-FD00-55010-000000-		175.84		
	755-7700 Oct 24		2100-FD-FD00-55010-000000-		100.62		
1681095	09/27/2024	PRINTED	001551 BREWPRO	1,753.50			
	126964		2040-RD-RD00-54550-IHCRCK-		1,753.50		
1681096	09/27/2024	PRINTED	004004 BUTLER COUNTY PROSECUTOR'	2,039.75			
	Case 23-2798		2620-PD-PD00-43540-BCPROS-		497.25		
	Case 23-88		2620-PD-PD00-43540-BCPROS-		386.25		
	Case 23-5143		2620-PD-PD00-43540-BCPROS-		1,156.25		
1681097	09/27/2024	PRINTED	004190 BUTLER COUNTY SHERIFF'S O	46,170.68			
	wCRange2023		2090-PD-PD00-57010-000000-		16,246.72		
	6673		2100-FD-FD00-54810-000000-		498.96		

AP CHECK RECONCILIATION REGISTER

FOR CASH ACCOUNT: 9999-00-0000-10110-000000-000000

FOR: All Except Stale

CHECK #	CHECK DATE	TYPE	VENDOR NAME	UNCLEARED	CLEARED	BATCH	CLEAR DATE
6593			2010-RD-RD00-54830-000000-		53.10		
		INVOICE NO	ACCOUNT		AMOUNT		
6593			2090-DS-DS00-54830-000000-		497.56		
6593			2090-PD-PD00-54830-000000-		101.95		
6593			2100-DS-DS00-54830-000000-		497.56		
6593			2100-FD-FD00-54830-000000-		99.83		
6592			2010-RD-RD00-54830-000000-		101.96		
6592			2090-DS-DS00-54830-000000-		955.31		
6592			2090-PD-PD00-54830-000000-		195.75		
6592			2100-DS-DS00-54830-000000-		955.31		
6592			2100-FD-FD00-54830-000000-		191.67		
6591			2010-RD-RD00-54830-000000-		99.83		
6591			2090-DS-DS00-54830-000000-		935.41		
6591			2090-PD-PD00-54830-000000-		191.67		
6591			2100-DS-DS00-54830-000000-		935.41		
6591			2100-FD-FD00-54830-000000-		187.68		
6590			2010-RD-RD00-54830-000000-		965.36		
6590			2090-DS-DS00-54830-000000-		9,045.59		
6590			2090-PD-PD00-54830-000000-		1,853.54		
6590			2100-DS-DS00-54830-000000-		9,045.59		
6590			2100-FD-FD00-54830-000000-		1,814.92		
6589			2010-RD-RD00-54830-000000-		29.75		
6589			2090-DS-DS00-54830-000000-		278.63		
6589			2090-PD-PD00-54830-000000-		57.09		
6589			2100-DS-DS00-54830-000000-		278.63		
6589			2100-FD-FD00-54830-000000-		55.90		
1681098	09/27/2024	PRINTED	004008 BUTLER COUNTY WATER & SEW	54.04			
	2060099 Sep 24		1010-PK-PK03-55030-000000-		54.04		
1681099	09/27/2024	PRINTED	000218 DELL MARKETING L.P.	1,661.50			
	10773299087		1010-AD-AD00-54810-000000-		1,661.50		
1681100	09/27/2024	PRINTED	001334 DUKE ENERGY	33,066.01			
	910117893186 Sep 24		1010-PK-PK04-55040-000000-		28.23		
	910118689401 Sep 24		1010-PK-PK04-55040-000000-		27.19		
	910127970038 Sep 24		1010-PK-PK14-55040-000000-		36.45		
	910117632260 Sep 24		2100-FD-FD00-55040-000000-		1,215.94		
	910119040434 Sep 24		2100-FD-FD00-55040-000000-		1,273.55		
	910117891887 Sep 24		1010-AD-AD00-55040-000000-		11.49		
	910117891887 Sep 24		1010-CD-CD00-55040-000000-		7.66		
	910117891887 Sep 24		2030-RD-RD00-55040-000000-		84.28		
	910117891887 Sep 24		2090-PD-PD00-55040-000000-		279.64		
	910117892010 Sep 24		1010-PK-PK03-55040-000000-		173.74		
	910117892599 Sep 24		1010-PK-PK03-55040-000000-		50.19		
	910117893326 Sep 24		1010-PK-PK11-55040-000000-		572.50		
	910117893417 Sep 24		1010-LT-LT00-55040-000000-		25.89		
	910119395751 Sep 24		1010-PK-PK12-55040-000000-		1,426.52		
	910119396140 Sep 24		2100-FD-FD00-55040-000000-		1,087.08		
	910119396190 Sep 24		2050-CE-CE00-55040-000000-		187.49		

AP CHECK RECONCILIATION REGISTER

FOR CASH ACCOUNT: 9999-00-0000-10110-000000-000000

FOR: All Except Stale

CHECK #	CHECK DATE	TYPE	VENDOR NAME	UNCLEARED	CLEARED	BATCH	CLEAR DATE
910119661924	Sep 24		2050-CE-CE00-55040-000000-		28.19		
		INVOICE NO	ACCOUNT		AMOUNT		
		910117892680	Sep 24 1010-PK-PK04-55040-000000-		105.35		
		910117632301	Sep 24 2100-FD-FD00-55040-000000-		1,158.98		
		910117891655	Sep 24 1010-AD-AD00-55040-000000-		2,840.37		
		910117891655	Sep 24 2070-PI-PI00-55040-000000-		387.32		
		910117893003	Sep 24 1010-AD-AD00-55040-000000-		1,258.47		
		910117893003	Sep 24 2070-PI-PI00-55040-000000-		179.78		
		910117893003	Sep 24 2090-DS-DS00-55040-000000-		565.02		
		910117893003	Sep 24 2100-DS-DS00-55040-000000-		565.02		
		910119396231	Sep 24 1010-AD-AD00-55040-000000-		75.19		
		910119396231	Sep 24 2050-CE-CE00-55040-000000-		25.06		
		910119396231	Sep 24 2070-PI-PI00-55040-000000-		9.81		
		910119396231	Sep 24 2090-DS-DS00-55040-000000-		34.33		
		910119396231	Sep 24 2100-DS-DS00-55040-000000-		34.33		
		910119396231	Sep 24 2100-FD-FD00-55040-000000-		3,051.53		
		910117893144	Sep 24 1010-PK-PK13-55040-000000-		682.89		
		910117892440	Sep 24 1010-AD-AD00-55040-000000-		98.76		
		910117892953	Sep 24 1010-AD-AD00-55040-000000-		396.82		
		910117892953	Sep 24 1010-CD-CD00-55040-000000-		264.53		
		910117892953	Sep 24 2030-RD-RD00-55040-000000-		2,909.88		
		910117892953	Sep 24 2090-PD-PD00-55040-000000-		9,655.55		
		910117891788	Sep 24 1010-LT-LT00-55040-000000-		508.58		
		910117893540	Sep 24 1010-LT-LT00-55040-000000-		1,742.41		
1681101	09/27/2024	PRINTED	004024 DUKE ENERGY	23,701.86			
		910117892169	Oct 24 5070-LT-LT01-55040-000000-		386.28		
		910117891134	Oct 24 5070-LT-LT01-55040-000000-		177.42		
		910117893277	Oct 24 5070-LT-LT02-55040-000000-		772.76		
		910117892218	Oct 24 5070-LT-LT04-55040-000000-		1,425.27		
		910117892911	Oct 24 5070-LT-LT05-55040-000000-		280.81		
		910117891233	Oct 24 5070-LT-LT06-55040-000000-		1,753.24		
		910117893590	Oct 24 5070-LT-LT07-55040-000000-		2,466.60		
		910119395975	Oct 24 5070-LT-LT08-55040-000000-		152.80		
		910117891366	Oct 24 5070-LT-LT09-55040-000000-		545.36		
		910117893649	Oct 24 5070-LT-LT10-55040-000000-		1,181.52		
		910117891514	Oct 24 5070-LT-LT11-55040-000000-		1,266.01		
		910117891415	Oct 24 5070-LT-LT12-55040-000000-		674.64		
		910117892250	Oct 24 5070-LT-LT12-55040-000000-		370.49		
		910117892630	Oct 24 5070-LT-LT13-55040-000000-		2,323.07		
		910119396067	Oct 24 5070-LT-LT16-55040-000000-		320.82		
		910119395800	Oct 24 5070-LT-LT16-55040-000000-		118.57		
		910119396091	Oct 24 5070-LT-LT16-55040-000000-		143.83		
		910117892490	Oct 24 5070-LT-LT17-55040-000000-		2,112.66		
		910119395686	Oct 24 5070-LT-LT19-55040-000000-		287.40		
		910117891564	Oct 24 5070-LT-LT19-55040-000000-		357.80		
		910119395892	Oct 24 5070-LT-LT19-55040-000000-		664.67		
		910117892838	Oct 24 5070-LT-LT19-55040-000000-		272.57		
		910117893053	Oct 24 5070-LT-LT19-55040-000000-		164.81		
		910117891960	Oct 24 5070-LT-LT20-55040-000000-		370.67		

AP CHECK RECONCILIATION REGISTER

FOR CASH ACCOUNT: 9999-00-0000-10110-000000-000000

FOR: All Except Stale

CHECK #	CHECK DATE	TYPE	VENDOR NAME	UNCLEARED	CLEARED	BATCH	CLEAR DATE
910117891332	Oct 24		5070-LT-LT22-55040-000000-		118.44		
		INVOICE NO	ACCOUNT		AMOUNT		
		910117892119	Oct 24 5070-LT-LT22-55040-000000-		209.75		
		910117892341	Oct 24 5070-LT-LT24-55040-000000-		198.50		
		910117892721	Oct 24 5070-LT-LT25-55040-000000-		740.91		
		910119395727	Oct 24 5070-LT-LT26-55040-000000-		105.92		
		910117152342	Oct 24 5070-LT-LT03-55040-000000-		359.24		
		910117152459	Oct 24 5070-LT-LT14-55040-000000-		335.08		
		910117801798	Oct 24 5070-LT-LT28-55040-000000-		601.89		
		910119133256	Oct 24 5070-LT-LT29-55040-000000-		350.93		
		910117152384	Oct 24 5070-LT-LT03-55040-000000-		1,209.35		
		910117152417	Oct 24 5070-LT-LT03-55040-000000-		881.78		
1681102	09/27/2024	PRINTED	004024 DUKE ENERGY	982.54			
			910117891837 Oct 24 5070-LT-LT28-55040-000000-		48.63		
			910117892549 Oct 24 5070-LT-LT28-55040-000000-		20.00		
			910117891465 Oct 24 5070-LT-LT15-55040-000000-		80.69		
			910119395933 Oct 24 5070-LT-LT16-55040-000000-		55.35		
			910119396017 Oct 24 5070-LT-LT19-55040-000000-		61.97		
			910117891605 Oct 24 5070-LT-LT22-55040-000000-		37.14		
			910117891704 Oct 24 5070-LT-LT22-55040-000000-		26.35		
			910117891928 Oct 24 5070-LT-LT22-55040-000000-		47.92		
			910117893095 Oct 24 5070-LT-LT22-55040-000000-		58.70		
			910117893491 Oct 24 5070-LT-LT22-55040-000000-		47.92		
			910117891085 Oct 24 5070-LT-LT23-55040-000000-		58.59		
			910117892789 Oct 24 5070-LT-LT22-55040-000000-		37.56		
			910117892060 Oct 24 5070-LT-LT25-55040-000000-		27.79		
			910118665792 Oct 24 5070-LT-LT25-55040-000000-		39.61		
			910117891283 Oct 24 5070-LT-LT25-55040-000000-		27.41		
			910117893467 Oct 24 5070-LT-LT25-55040-000000-		22.29		
			910117891184 Oct 24 5070-LT-LT25-55040-000000-		48.43		
			910117892391 Oct 24 5070-LT-LT27-55040-000000-		84.05		
			910118107656 Oct 24 5070-LT-LT27-55040-000000-		22.16		
			910117892888 Oct 24 5070-LT-LT27-55040-000000-		28.23		
			910118404280 Oct 24 5070-LT-LT27-55040-000000-		29.59		
			910117401978 Oct 24 5070-LT-LT27-55040-000000-		72.16		
1681103	09/27/2024	PRINTED	002792 FORCE SCIENCE LTD	545.00			
			FSI-31868 2090-PD-PD00-53410-000000-		545.00		
1681104	09/27/2024	PRINTED	002136 FYDA FREIGHTLINER CINCINN	849.39			
			C007982087:01 2010-RD-RD00-53510-000000-		849.39		
1681105	09/27/2024	PRINTED	004356 HAMILTON COUNTY CORONER	110.00			
			19950 2090-PD-PD00-53190-000000-		110.00		
1681106	09/27/2024	PRINTED	004394 HEATHER PHILLIPS	1,690.50			
			HP6769 2040-RD-RD00-54550-IHCURB-		1,690.50		
1681107	09/27/2024	PRINTED	003471 MCBRIDE DALE ASSOCIATES I	2,250.00			

AP CHECK RECONCILIATION REGISTER

FOR CASH ACCOUNT: 9999-00-0000-10110-000000-000000

FOR: All Except Stale

CHECK #	CHECK DATE	TYPE	VENDOR NAME	UNCLEARED	CLEARED	BATCH	CLEAR DATE
	4284-42		1010-CD-CD00-53190-000000-		2,250.00		
1681108	09/27/2024	PRINTED	002776 MIKE CASTRUCCI FORD INC	852.28			
	INVOICE NO		ACCOUNT		AMOUNT		
	153824		2090-PD-PD00-53510-000000-		187.27		
	153822		2090-PD-PD00-53510-000000-		665.01		
1681109	09/27/2024	PRINTED	002095 OBERER'S FLOWERS 04924063 2090-PD-PD00-56040-000000-	77.90	77.90		
1681110	09/27/2024	PRINTED	004369 THE OHIO HISTORICAL SOCIE Krutka 9/25/24 1010-AD-AD00-53410-000000-	20.00	20.00		
1681111	09/27/2024	PRINTED	004200 RONNIE SAWYER Sawyer 09/24/24 1010-PK-PK00-53410-000000-	85.11	85.11		
1681112	09/27/2024	PRINTED	003777 OLGA ONIPKO 35211 (A) 2090-PD-PD00-53190-000000- 35211 (B) 2090-PD-PD00-53190-000000-	40.00	20.00 20.00		
1681113	09/27/2024	PRINTED	004010 TREASURER OF STATE OF OHI 25L1129 2090-PD-PD00-53190-000000-	600.00	600.00		
1681114	09/27/2024	PRINTED	003759 UNIFIRST CORPORATION 1340367303 1010-PK-PK00-54550-000000- 1340367303 1010-PK-PK00-54720-000000- 1340367303 1010-SV-SV99-54720-000000- 1340367303 2010-RD-RD00-54550-000000- 1340367303 2010-RD-RD00-54720-000000- 1340367303 2050-CE-CE00-54720-000000-	404.08	38.59 26.93 75.29 20.41 223.78 19.08		
1681115	09/27/2024	PRINTED	004386 WOODLAWN IAFF LOCAL 3746 2024-2 2100-FD-FD00-53410-000000-	45.00	45.00		
148 CHECKS				CASH ACCOUNT TOTAL	749,659.86	731,748.10	

AP CHECK RECONCILIATION REGISTER

		UNCLEARED	CLEARED
148 CHECKS	FINAL TOTAL	749,659.86	731,748.10

** END OF REPORT - Generated by Felicia Krutka **

AGENDA ITEM COVER SHEET



Trustee Meeting Date:	Agenda Item Type:
October 8, 2024	Requisition Item
Submitted By:	
Larry D. Burks, Township Administrator	

Motion:
BluePaz LLC - \$25,000.00 - Purchase Peer Support training

Background:								
<p>In February 2022 the Township developed a Behavioral Health Committee to help support the mental health needs of all Township employees. The committee identified peer-to-peer support as an integral part of a successful behavioral health initiative. Peer support provides a way for employees to confidentially talk about personal/professional problems with specially trained co-workers. Peer support helps develop a sense of connectedness, reduces stigma and assists the individual in locating additional support, if needed.</p> <p>Throughout 2022 and 2023 the framework for the Township’s Peer Support Team was developed and in May 2023 participants attended a multi-day Basic Peer Support Training. In 2023, these team members provided support to their colleagues on 38 known occasions, with 34% of these contacts referred to additional resources. Today, the West Chester Township Peer Support Team is includes 16 members from across various Township departments.</p> <p>Ohio Revised Code Section 2317.023 provides guidelines relative to testimonial privilege when providing peer support services. Among other requirements, the ORC requires team members complete at least 16 hours of basic peer support training, and no less than eight hours of peer support training every two years.</p> <p>After reviewing proposals from several peer support training organizations and consulting with the Township’s First Responder Wellness provider, BluePaz LLC was selected as the preferred vendor to conduct this training. While the BluePaz proposal is more costly, this comprehensive training program covers the materials included in the other individual programs. Additionally, the BluePaz training is one week in duration and led by three trainers. The training team allows the program to be customized to the Township’s needs, including breakout sessions for more individualized training. The training includes the following topics:</p> <table border="0"> <tr> <td>Building a Comprehensive Peer Support & Wellness Program</td> <td>Advanced Peer Support</td> </tr> <tr> <td>Fundamentals of Critical Incident Stress Management (CISM)</td> <td>Group Crisis Intervention Services</td> </tr> <tr> <td>Critical Incident Stress Debrief (CISD)</td> <td>Navigating First Responder Resources & Trauma Treatment Options</td> </tr> <tr> <td>Peer Support Task Force Teams &</td> <td>Resiliency, Avoiding Compassion Fatigue & Self-Care</td> </tr> </table> <p>The BluePaz LLC five-day training is \$25,000 and includes instruction for up to 50 attendees and BluePaz travel expenses. The Township will utilize unexpended funds from the ARPA First Responder Wellness Grant Program to pay for this training. The Township received these funds September 2024 and will complete the training April 7-11, 2025.</p>	Building a Comprehensive Peer Support & Wellness Program	Advanced Peer Support	Fundamentals of Critical Incident Stress Management (CISM)	Group Crisis Intervention Services	Critical Incident Stress Debrief (CISD)	Navigating First Responder Resources & Trauma Treatment Options	Peer Support Task Force Teams &	Resiliency, Avoiding Compassion Fatigue & Self-Care
Building a Comprehensive Peer Support & Wellness Program	Advanced Peer Support							
Fundamentals of Critical Incident Stress Management (CISM)	Group Crisis Intervention Services							
Critical Incident Stress Debrief (CISD)	Navigating First Responder Resources & Trauma Treatment Options							
Peer Support Task Force Teams &	Resiliency, Avoiding Compassion Fatigue & Self-Care							

Finance	Budgeted Item:	N/A;		
	CIP #:			
	TIF Info:			
	Purchase Order:	24003057	Total Encumbrance:	\$ 25,000.00

5-DAY Peer Support Training AGENDA
Presented by BluePaz First Responder Services

Critical Incident Stress Management – Group Crisis Intervention

DAY 1:

0800-0900 hours

- **Welcome & Introductions**

0900-1000 hours

- **Fundamentals of Critical Incident Stress Management (CISM)**

1000-1530 hours

- **Group Crisis Intervention Services**
 - Relevant Research Findings & Recommendations for Practice
 - Incident Assessment
 - Strategic Intervention Planning
 - “Resistance, Resilience, Recovery” Continuum

1130-1230 hours

- **Lunch**

1530-1600 hours

- **Discussion & Wrap-up**

DAY 2:

0800-0830 hours

- **Welcome & Discussion**

0830-1500 hours

- **Group Crisis Intervention Services (continued)**
 - Large Group & Small Group Crisis Interventions
 - Adverse Outcome Associated w/ Crisis Intervention & Reducing Risks
- **Critical Incident Stress Debrief (CISD)**
- **Overview of SAFER Model**

1130-1230 hours

- **Lunch**

1500-1600 hours

- **Discussion & Wrap Up**

Building A Comprehensive Peer Support & Wellness Program / Advanced Peer Support Training

DAY 3:

0800-0900 hours

- **Welcome & Introductions**

0900-1030 hours

- **“Helping Our Own” Presentation**

1030-1200 hours

- **First Responder Mindset, Challenges & Peer Support Assistance**

1200-1300 hours

- **Lunch**

1300-1530 hours

- **Building Components of a Comprehensive Peer Support & Wellness Program**
 - Agency Buy-In
 - Identify Team Function
 - Determine Team Structure Model (Self-Sustaining vs. Task Force Team)
 - Selection of Team Members
 - Mental Health Advisor Oversight
 - Provide Team Training
 - Create Community Partnerships
 - Sustain & Analyze Team
 - Implement Resource Networking & Coordination
 - Incorporate Wellness Initiatives & Support Programs
- **Peer Support Task Force Teams & Regional Responses**

1530-1600 hours

- **Discussion & Wrap-up**

DAY 4:

0800-0900 hours

- **Welcome & Discussion**

0900-1100 hours

- **Active Peer Support Communications & Responses**

1100-1200 hours

- **SI, PTS & Grief**

1200-1300 hours

- **Lunch**

1300-1530 hours

- **Best Practice Guidelines for Peer Support Responses**
 - Critical Incident/OIS Callout Response
 - Contact AFTER Critical Incident
 - Long-term Injury/Illness
 - Employee Hospitalizations
 - Department Investigations/Disciplinary Actions
 - Employee Substance Response
 - Employee Crisis Intervention
 - Officer Retirement Support
 - LODD***

1530-1600 hours

- **Discussion & Wrap-up**

DAY 5:

0800-0830 hours

- **Welcome & Discussion**

0830-1000 hours

- **Navigating First Responder Resources & Trauma Treatment Options**

1000-1100 hours

- **Resiliency, Avoiding Compassion Fatigue & Self-Care**

1100-1200 hours

- **Next Steps & Wrap Up**

From
BluePaz, LLC
7000 N 16th St Ste.120 #158
Phoenix, AZ 85020-5524



Quote

Bill To
Attn: Kellie Byrd

Quote
#1790

Client
West Chester/ Cincinnati Ohio

Provider
BluePaz, LLC
Tax ID: 83-0831402
NPI: #1043727167
(602) 345-1425
Psychologists@dr.com

Responsible Party
Attn: Kellie Byrd
kbyrd@westchesteroh.org

Date	Description	Amount
07/12/2024	Peer Support Certification & Training (December 2nd- 6th, 2024; up to 50 participants; Certification in Basic ICISF CISD and in BluePaz advanced Peer Support Training)	\$25,000.00
	Subtotal	25,000.00
	Total	25,000.00
	Amount Paid	0.00
	Balance	\$25,000.00

Notes

Thank you for the opportunity to be of service!

Vicki Hixson, M.Ed.
Critical Incident Consulting Inc., Owner
vicki@criticalconsulting.com



Vicki Hixson owns and operates Critical Incident Consulting, LLC; a public safety peer support and wellness consulting firm. Vicki contracts and consults with various public safety agencies in Arizona to design and implement tailored wellness programs for employees while being cognizant of each employers' varied needs. The firm focuses on customized practices such as the building of peer support teams and comprehensive wellness programs, resiliency and advanced peer support training, resource vetting and coordination with community mental health partners, identifying preventative employee care strategies, as well as the developing of written policy. She is also well versed in individual employee crisis situations to include collaborative resource solutions for these often highly complex and dynamic return-to-work circumstances.

She is the co-creator and co-host of the Ride Along Chronicles podcast. A social podcast focusing on the unique challenges of first responder families told through confidential storytelling.

Vicki has been in law enforcement for over 25 years. She retired as a Mesa, AZ Police Detective in 2018. Although Vicki is still currently working as a sworn police detective in a smaller police agency, it is during her tenure with the Mesa Police Department where she developed a unique skillset focused on the mental health and wellness of first responders.

While at Mesa PD she worked as a Patrol Officer, Major Crimes Detective, and Financial Crimes Detective. She was also a Policy and Procedures Detective responsible for the research of industry best practices, policy and procedure development, and writing of policy for almost 4 years. During that time, she also served as a part-time peer support member for 10 years before being selected as the full-time Peer Support and Wellness Coordinator in 2013.

As the Peer Support and Wellness Coordinator, Vicki managed a team of over 40 part-time Peer Support Team members who provided peer support and wellness services to over 1200 public safety employees. She enhanced Mesa PD's program and elevated it to be recognized as top-tier within the state. She facilitated crisis management interventions, conducted post-critical incident debriefs, provided resource identification, treatment coordination, and follow-up employee care. She facilitated and taught a research-based resiliency training program to all sworn and professional staff members within the department and outside agencies. She built employee partnerships with mental health providers, behavioral health/substance treatment facilities, and financial resources. She also designed and implemented a return-to-work program for first responders who experienced a critical incident or crisis event. Vicki created collaborative partnerships with other public safety agencies to enhance their agencies' wellness programs. She is regarded as a Subject Matter Expert in first responder stress and wellness in Arizona.

Vicki holds a Bachelor of Science in Criminal Justice and Women Studies from Rutgers University, and a master's degree in Education from Northern Arizona University. She has been an Executive Board Member for the Arizona Public Safety Peer Support Association for over 10 years and has been integral in assisting individuals and agencies throughout the state. She has been married to a police officer for over 25 years and has three adult children.

Kelley Meshirer



Kelley has served Public Safety since 2012 through various non-profit avenues and has experience, leadership, and training in areas including critical incidents, suicide prevention/intervention, peer support, and mental health. She has been a first responder spouse to a 26-and-a-half-year veteran of federal law enforcement since 2004. She has navigated several critical incidents and line-of-duty injuries throughout her husband's career. The most life-changing in 2018 when he was involved in a line-of-duty shooting incident and survived. She attributes her wellness to hard work and the support they received from her husband's agency, friends, family, community, and primarily her faith. She also greatly recognizes the benefit her family received from the counseling of a trauma specialist. Kelley is an honors graduate from Liberty University with a Master's in Addiction Counseling and is currently a doctoral student seeking her Ph.D. in Psychology focused on Trauma. She practices at Thrive with Chaos and is an ICISF Instructor for Critical Incident Stress Management. She trains on several other subjects including suicide prevention, resiliency, post-traumatic growth, the nervous system and stress response, and first responder couples. She lives in Southern Arizona with her family.

Dara N. Rampersad, Ph.D., LPC, NCC



Dr. Dara Rampersad is a First Responder and Forensic psychologist who is licensed in both Arizona and Hawaii. He is certified in Crisis Intervention Teams (CIT) as a CIT Coordinator, and is trained in Critical Incident Stress Management (CISM) and FBI- Crisis Negotiator Teams (CNT). In addition, Dr. Rampersad is licensed as a professional counselor in Colorado, and is nationally board certified in counseling, with over 25 years of experience in the mental health field.

Dr. Rampersad owns and operates BluePaz First Responder Services, which hosts annual first responder health and wellness conferences and provides counseling, consulting, coaching, critical incident stress debriefings, and training to first responders and their departments on resiliency, stress management and other pertinent topics.

Dr. Rampersad helped to start the world's first hospital-based CIT program, and he currently serves as the Security Special Operations Senior Director of Crisis Services for a large multi-state hospital system. He is also a Professor of Practice at Arizona State University where he is creating a first of its kind program to teach counselors how to treat First Responders. In addition, he is an instructor at the Naval Postgraduate School- Executive Leadership Program training law enforcement agencies, fire departments, hospital staff, paramedics, and other first responders on Crisis Response, PTSD, Resiliency and Mental Health Tactical Intervention (MHTI).

Dr. Rampersad is a founding member and first President of the Arizona CIT Association. He also served on the CIT International board of directors and is an active board member of EMSHelp, Mesa Police Department mental health advisory board, and Phoenix Fire Department paramedic training advisory board.

Dr. Rampersad works with the Peoria Police and other departments as a member of their peer support team, and was also involved as a team leader for an International Association of Chiefs of Police (IACP) policy group, revising policies and procedures for how law enforcement assist people in mental health crisis.

Dr. Rampersad helped to launch Maui County Police Department's and the State of Hawaii's very first CIT program aimed to improve first responder service delivery to people living with mental illness. During this time, he was also able to assist in starting Maui County's first felony/circuit court mental health court, and he was selected by CIT International as an international behavioral health practitioner of the year.

Dr. Rampersad has appeared on multiple television and radio programs to speak on law enforcement response to mental health, violence risk assessment, homelessness, and other mental health issues. He has also served as an expert witness in complex judicial cases involving involuntary hospitalization and fitness to proceed issues.

Dr. Rampersad has been given letters of commendation by the Governor of Hawaii and the Mayor and Chief of Police of Maui County for his pioneering work in the field of mental health. He was also lauded by and received commendations from the Phoenix Police Department for his assistance in selecting their CIT detective squads, and for his ongoing work in assisting law enforcement as a first responder psychologist.

AGENDA ITEM COVER SHEET



Trustee Meeting Date:	Agenda Item Type:
October 8, 2024	Requisition Item
Submitted By:	
Larry D. Burks, Township Administrator	

Motion:
The Wonder Within LLC - \$20,000.00 - Purchase quarterly wellness sessions

Background:
<p>In June 2022, the Board of Trustees approved the Township’s application for the American Rescue Plan Act (ARPA) First Responder Wellness, Recruitment, Retention, and Resiliency Grant. This grant is administered by the Ohio Department of Public Safety and provides funding for first responder wellness, hiring, and retention for police officers, firefighters, and communication officers. In November 2022, the Township was awarded \$179,200 for First Responder Wellness (the remaining portions of the grant are under review by a different board). The Township’s First Responder Wellness Program provides annual mental health check-ins for all first responders, which includes all personnel from the Police, Fire/EMS, and Communications Departments.</p> <p>The Township would like to supplement the First Responder Wellness Program with the holistic services provided by The Wonder Within (TWW). TWW programs address the unique physical, mental and emotional needs of first responders, veterans and front line personnel. TWW recognizes that these individuals work in high-stress and sometimes traumatic situations, which can take a toll on their overall health and well-being.</p> <p>The Township requested quotes from TWW and other like-providers. TWW provided the most responsive and cost-effective proposal. TWW program will include quarterly wellness sessions to promote mental, emotional and physical wellbeing. Their holistic approach to treating the mind and body will significantly benefit Township personnel. Quarterly programming includes: Leading Mindfully, Resiliency, Rest and Digest, and Injury Prevention and Treatment. These quarterly sessions will be held at each of the Township’s fire stations and available to all Township personnel.</p> <p>The Township will utilize unexpended funds from the original ARPA First Responder Wellness Grant Program proposal. The Township received these funds September 2024 for services provided through December 31, 2025. A \$2,000 contingency has been included incase additional wellness services need to be provided to our employees.</p>

Finance	Budgeted Item:	N/A;		
	CIP #:			
	TIF Info:			
	Purchase Order:	24003047	Total Encumbrance:	\$ 20,000.00

The Wonder Within
6835 Township Road 91
Mount Gilead, OH 43338 US
thewonderwithinllc@gmail.com



Quote

ADDRESS

West Chester Township

QUOTE # 1094

DATE 07/22/2024

ACTIVITY	QTY	RATE	AMOUNT
West Chester Quarterly Wellness Session Our on-site wellness sessions are meticulously designed to support the continuous mental, physical, and emotional well-being of participants, aiming to prevent overwhelm, stress, and suicide. Each session is tailored to address your team's unique needs, providing tools for personal and professional thriving. **Leading Mindfully:** This workshop helps participants evaluate and enhance their coping mechanisms, identifying stressors and triggers to improve self-awareness and well-being. Ideal for those in service careers, it emphasizes the importance of self-care. **Relate/Resiliency 101:** Specifically for veterans and first responders, this session focuses on self-awareness, resilience-building, and effective communication, improving personal and professional relationships through stronger self-connection. **Rest & Digest:** Participants will learn to optimize sleep patterns and adopt mindful relaxation techniques, promoting sustained vitality and balanced lifestyles through quality rest and rejuvenation. **Injury Prevention & Treatment:** This interactive workshop teaches Tune-Up therapy ball techniques for preventing and treating minor aches and injuries, enhancing physical resilience and performance. Quarterly sessions will be held at five fire	15	1,200.00	18,000.00

ACTIVITY	QTY	RATE	AMOUNT
----------	-----	------	--------

stations in West Chester, running for three consecutive weeks on Wednesdays: November 6, 13, 20, 2024; February 5, 12, 19, 2025; May 7, 14, 21, 2025; August 6, 13, 20, 2025; and November 5, 12, 19, 2025. Each 45-minute session will include mobility exercises, yoga, IREST, myofascial massage, breathwork, and sleep training. Our team will conduct five back-to-back sessions at all five West Chester fire stations, beginning at 8 AM, 9 AM, 10 AM, 11 AM, and 12 PM. These services will be billed at a quarterly rate.

Thank you for your business.	SUBTOTAL	18,000.00
	TAX	0.00
	TOTAL	\$18,000.00

Accepted By

Accepted Date

AGENDA ITEM COVER SHEET



Trustee Meeting Date:	Agenda Item Type:
October 8, 2024	Requisition Item
Submitted By:	
Larry D. Burks, Township Administrator	

Motion:
MP Digital LLC - \$10,290.00 - Purchase user licenses

Background:
<p>Laserfiche is an enterprise content management (ECM) and workflow automation platform widely used by West Chester Township to streamline various processes.</p> <p>Currently, Laserfiche is applied to several key workflows: Agenda Management, Online Plan Submittal, Incident and Injury Reporting, and Park Reservations.</p> <p>These workflows improve the efficiency of township operations and ensure compliance, accountability, and easier document retrieval.</p> <p>Approval is requested for forty-one Laserfiche User Licenses totaling \$10,290.00.</p> <p>Thank you for your consideration.</p>

Finance	Budgeted Item:	Yes; Operational		
	CIP #:			
	TIF Info:			
	Purchase Order:	24003069	Total Encumbrance:	\$ 10,290.00



ESTIMATE

MP Digital LLC
P.O.Box 573
Worthington, Ohio 43085
United States

Mobile: (614) 563-9729
www.mpecm.com

BILL TO
West Chester Township
West Chester Township

info@westchesterOH.org

Estimate Number: 02082036

Estimate Date: September 10, 2024

Valid Until: October 18, 2024

Estimate Total (USD): **\$32,439.23**

Product/Service	Quantity	Price	Amount
Laserfiche LSAP Year 1	1	\$10,290.00	\$10,290.00
Laserfiche LSAP Year 2	1	\$10,804.50	\$10,804.50
Laserfiche LSAP Year 3	1	\$11,344.73	\$11,344.73

Total: \$32,439.23

Estimate Total (USD): **\$32,439.23**

Notes / Terms

Current Laserfiche Deployment
Avante Server for MS SQL
Import Agent
Forms Portal
Forms Professional
Records Management Module
Participant Users - Four (4)
Named Full Users with Web Client - Forty One (41)

Thank you for the opportunity!

Powered by  wave

AGENDA ITEM COVER SHEET



Trustee Meeting Date:	Agenda Item Type:
October 8, 2024	Requisition Item
Submitted By:	
Dennis Dick, Director of Communications and Information Technology	

Motion:
Strategic Sourcing, Inc. - \$28,910.00 - Replace mobile computers for EMS patient care reporting (CIP 1892)

Background:
<p>Request approval for replacement of seven mobile computers for EMS patient care reporting.</p> <p>The current devices are no longer under warranty and have exceeded useful life. These devices are used by EMS staff on all runs involving treatment of patients and are critical to creating an electronic patient care record. These records are used by hospitals, patient billing, and to comply with state and/or federal reporting requirements.</p> <p>This purchase includes a five year extended "bumper to bumper" warranty which has a proven return on investment with past units due to the extreme environment and conditions these units are utilized in.</p> <p>Thank you for your consideration.</p>

Finance	Budgeted Item:	Yes; CIP		
	CIP #:	1892		
	TIF Info:			
	Purchase Order:	24002978	Total Encumbrance:	\$ 28,910.00



6145 Scherers Place
 Suite A
 Dublin, Ohio 43016
 p. 614-760-3990
 f. 614-961-3598
www.stratsourcing.com

Quotation

Quote #	62271
Terms	NET 30
Contact	Hector Ortiz hortiz@westchesteroh.org +1 513-777-1133
Quote Date	9/11/2024
Expires	12/10/2024

Sales Rep: Howard Mandel
hmandel@stratsourcing.com
 p. 513 310 5411

Customer

West Chester Fire
 Hector Ortiz
 9119 Cincinnati Dayton Road
 West Chester, OH 45069
 UNITED STATES
 +1 513-777-1133
hortiz@westchesteroh.org

Bill To

West Chester Fire
 Accounts Payable
 9119 Cincinnati Dayton Road
 West Chester, OH 45069
 UNITED STATES
 +1 513-777-1133
ddick@westchesteroh.org

Ship To

West Chester Fire
 9119 Cincinnati Dayton Road
 West Chester, OH 45069
 UNITED STATES
 +1 513-777-1133

Description	Customer PO	Contract	Ship Via
West Chester FD - Getac V110 Quote - 9 11 24			FedEX Ground

Item	Mfg	Part #	Qty	Description	Price	Extended Price
1	Getac, Inc	VSCP6PJAB4BE	7	Getac V110G7 Fully Rugged Convertible Laptop - Intel Core i5 12th Gen i5-1235U Processor, 11.6" Touch Screen + Sunlight Viewable + Full HD Display, Windows 11 Pro, 16 Gb Memoery, 256 Gb SSD Hard Drive, WIFI, Bluetooth, 4G Cellular (First Net Compliant), GPS, Psss Thru, Backlit Keyboard, Hard Handle, 1D/2D Bar Code Reader, USB Type A X 2, USB Type C X 1, 3 Year Bumper to Bumepw Warranty	\$3,580.00	\$25,060.00
2	Getac, Inc	GE-SVTBNFX5Y	7	Getac 5 Year Extended Bumper to Bumper Warranty (Optional)	\$550.00	\$3,850.00

Sub Total: \$28,910.00
 Shipping and Handling: \$0.00
 Tax Rate: (0.000000) \$0.00
Total \$28,910.00

Totals may not include appropriate Taxes or Shipping Fees.
 All prices are subject to change without notice. Supply subject to availability.
 All Quotes and Pricing are Proprietary and Confidential.

AGENDA ITEM COVER SHEET

Trustee Meeting Date:	Agenda Item Type:
October 8, 2024	Requisition Item
Submitted By:	
Rick L. Prinz, Fire Chief	

Motion:
Vogelpohl Fire Equipment, Inc. - \$11,399.40 - Purchase fire hose (CIP 1633)

Background:
<p>CIP 1633 is created each year to purchase needed fire attack and supply hose for the department. Recognizing the needs to have reserve supply at each of our five stations to allow the response vehicles to remain in their district and minimize response time, BC Tully has created allotment levels for the stations, as well as headquarters. To maintain these levels and have hose for all eight allotted fire apparatus, the fire department is in need of the hose listed in the page "Hose Request for 2024". Three quotes have been obtained and Vogelpohl is the lowest quote, at a cost of \$11,399.40, which includes shipping.</p> <p>Please approve PO 24002992 to fulfill CIP 1633 and ensure proper amounts of hose are ready for fire extinguishment.</p>

Finance	Budgeted Item:	Yes; Operational, CIP		
	CIP #:	1633		
	TIF Info:			
	Purchase Order:	24002992	Total Encumbrance:	\$ 11,399.40

24002992

QUOTE



**VOGELPOHL
FIRE EQUIPMENT**

2770 Circleport Drive Erlanger, KY 41018
www.vogelpohlfire.com

Quote #: Q011152
Date: Sep 20, 2024
Expiration: Oct 18, 2024
Contact: Mike Rust
Cell: 859-653-0183
Email: mike.rust@vogelpohlfire.com

ISSUED TO
Brandon Tully
West Chester Fire Dept
9119 Cinti-Dayton Road
West Chester OH 45069

Qty	Description	Payment Terms	Freight	Each	Extended
		Net Due in 15 Days	Not Included		
7	Key Hose, RC50-450, 5" x 100' PRO-FLOW LDH, Rubber Covered Supply Line with Storz Aluminum couplings, color is YELLOW			\$843.60	\$5,905.20
6	Key Hose, DP20-1000, 2" x 2.5" x 50 Combat Ready Attack Line With 2.5" Aluminum NST Couplings, treated, color is GREEN			\$393.30	\$2,359.80
8	Key Hose, DP18-800-FDNY, 1.75" x 50' Big 10 Attack Line with Aluminum NST Couplings , treated, color is WHITE			\$195.90	\$1,567.20
4	Key Hose, DP18-800-FDNY, 1.75" x 50' Big 10 Attack Line with Aluminum NST couplings, treated, color is RED			\$195.90	\$783.60
4	Key Hose, DP18-800-FDNY, 1.75" x 50' Big 10 Attack Line with Aluminum NST Couplings, treated, color is ORANGE			\$195.90	\$783.60
1	FREIGHT-S: Freight for Equipment, NO Charge			\$.00	\$.00
					\$11,399.40

Thank you for the opportunity to provide you with this proposal.



NAFECO

(/)

☰ ALL CATEGORIES

29

Fall Uniform Sale Going On Now (/Uniforms)

(/) Shopping Cart

Shopping Cart

Subtotal: \$11,803.00 (29 items)



Key Fire Hose, Big-10 Hose 1.75" x Length, DJ, 1.5" NH 50 Feet of Hose Red 1.75" x Length, DJ, 1.5" NH 50 Feet of Hose Red (/products/key-fire-hose/DP17-800-XX)
Item #DP17X50R15N

\$229.00 ea.

tot. \$916.00



Key Fire Hose, Big-10 Hose 1.75" x Length, DJ, 1.5" NH 50 Feet of Hose Orange (/products/key-fire-hose/DP17-800-XX)
Item #DP17X50O15N

\$229.00 ea.

tot. \$916.00



Key Fire Hose Big-10 Hose FDNY 1.75" x Length, DJ, 1.5" NH 50 Feet of Hose White (/products/key-fire-hose-big-10-hose-fdny-1-75-x-length/DP18-800-FDNY-XX)
 Item #DP18-800-FDNYX50W

\$254.00 ea.

tot. \$2,032.00



Key Fire Hose, Pro-Flow 4.0" x Length, 4" Storz 100 Feet of Hose yellow 4.0" x Length, 4" Storz 100 Feet of Hose yellow (/products/key-fire-hose/RC40-500-XX)
 Item #RC40X100Y40S

\$907.00 ea.

tot. \$6,349.00



Key Fire Hose, ECO-10 Hose 2.5" x Length, DJ, 2.5" NH 50 Feet of Hose Green 2.5" x Length, DJ, 2.5" NH 50 Feet of Hose Green (/products/key-fire-hose/DP25-800ECO-XX)
 Item #DP25GX50-800ECO

\$265.00 ea.

tot. \$1,590.00



Estimate Shipping Cost

Enter Zip Code

Subtotal \$11,803.00

Tax \$0.00

Shipping \$0.00

Tax and shipping calculated in checkout.

Total **\$11,803.00**

[Checkout \(/Checkout/Shipping\)](#)

[Subscribe To Our Mailing List \(/Pages/JoinMailingList\)](#)



NAFECO

(/)



Corporate Mailing Address:
P.O. Box 2928
Decatur, AL 35602-2928



Toll-Free: (800) 628-6233 (tel:1-800-628-6233)



Email Us:
info@nafeco.com (mailto:info@nafeco.com)



Normal Operating Hours:
M-F 8:00AM - 5:00PM CT



Your shopping cart includes the below emergency vehicle parts or equipment. Please review your cart and proceed to checkout if everything is in order!

PRODUCT NAME	QUANTITY	TOTAL	DELETE
FDNY SPEC HOSE	<input type="text" value="8"/>	\$1,852.48	×
FDNY SPEC HOSE	<input type="text" value="4"/>	\$926.24	×
FDNY SPEC HOSE	<input type="text" value="4"/>	\$926.24	×
KEY ECO-10 ATTACK HOSE	<input type="text" value="6"/>	\$1,441.86	×

PRODUCT NAME	QUANTITY	TOTAL	DELETE
HY-FLOW LDH SUPPLY HOSE	<input type="text" value="7"/>	\$6,991.25	×

[APPLY COUPON](#)
[UPDATE CART](#)

CART TOTALS

SUBTOTAL	\$12,138.07
SHIPPING	Calculate shipping
TAX	\$0.00
TOTAL	\$12,138.07

[PROCEED TO CHECKOUT](#)

firelineequipment.com		2024-09-25	
Secure Checkout	Verified Business	Certified Secure	No Malware

Thank You For Your Business!

The Fire Line Store

Hose request for 2024

Failed 4 sections of 5"

Would like to request the following hose for 2024

7 sections of 5" to replace the Four that were broken and to have sufficient hose for new engine

6 sections of green 2" to have adequate reserve and enough for the new engine

8 sections of white 1.88" Hose to have adequate reserve and have enough for a white line on the new engine

4 sections of red 1.88" for new line on reserve engine

4 sections of orange to have adequate reserve and have enough for apartment load for new engine.

AGENDA ITEM COVER SHEET



Trustee Meeting Date:	Agenda Item Type:
October 8, 2024	Requisition Item
Submitted By:	
Rick L. Prinz, Fire Chief	

Motion:
John Dsuban Spring Service - \$10,367.03 - Repair rear axle on Vehicle 1118

Background:
<p>Vehicle 1118 is one of the two primary Ladder/Engines in the West Chester Fire Department and is a 2018 E-One with 58,136 miles currently. The West Chester mechanics found the rear axle bushings were worn out. Attached is the estimate from Dsuban for the parts and labor needed to replace the rear bushings for the rear axle of the truck, as well as the torque rods. No competitive quotes are included, as the truck needed disassembled to properly assess the repairs needed.</p> <p>Please approve PO 24003093 for \$10,367.03.</p>

Finance	Budgeted Item:	Yes; Operational	
	CIP #:		
	TIF Info:		
	Purchase Order:	24003093	Total Encumbrance:



OPEN ESTIMATE
OF
REPAIRS

Dsuban SS Inc.
4830 Duff Dr.
Cincinnati, Oh. 45246
phone (513) 860-1200
fax (513) 860-1213

Date: 10/03/24	Open Estimate of Repairs
Customer: Westchester Fire	Vehicle: Fire Apparatus
	Make: E-One
Attention: don or doug	Model:
	Year: Nov-18
	Truck #: Ladder #75
	VIN: 4EN6ABA82J1001752
	PT code

Line	Item	Part Price	Body Labor Units	Refinish Labor Units	Mech/ Frame Labor units
1	Remove both rear beams to rebush				12
2	PARTS FOR BEAM REBUSH	\$ 5,761.92			
3	Reshim sway bar & replace bolts/washers	\$ 75.00			1
4	R/R side to side torque rod				1.25
5	R/R front to back torque rod	\$ 128.94			1.25
6	Check and adjust drive axle	\$ 173.67			2.75
7					
8	misc. parts /bolts if needed	\$ 125.00			
9	shop supplies	\$ 91.25			
10					
11	may have to order parts could take 6-7 days				
12	after approval, Plus shipping				
13	unable to EST shipping until ordered.	open			
	labor hour totals		0	0	18.25
	SubTotal	\$ 6,355.78	\$ -	\$ -	\$ 3,011.25
	SubTotal				9,367.03
	Tax				
	Total	\$			9,367.03

Estimate prepared by: Jacob I

Note: This is an open estimate only based on inspection & does not cover additional parts or labor that may be required after work has begun. Quotations on parts & labor are subject to change.

estimate is only good for 15 days due to rising parts prices

If estimate doesn't include tax it will still be applied after work is complete unless tax - exempt.

+1,000 shipping
10,367.03

AGENDA ITEM COVER SHEET



Trustee Meeting Date:	Agenda Item Type:
October 8, 2024	Requisition Item
Submitted By:	
Arun Hindupur, Director of Public Works/Community Services	

Motion:
Neyra Construction - \$57,636.93 - Resurface driveway at Voice of America (CIP 1260)

Background:
<p>Due to the condition of the driveway at Voice of America Museum, the Community Services Department created a 2024 CIP to resurface the driveway. The museum also plans to resurface their parking lot this year and we plan to coordinate so it will be done at the same time.</p> <p>The total amount is \$57,636.93 - breaking down the total, Alternate 2 is the Crosley Milling and Asphalt which totals \$35,426.05. The remaining amount is for the pave gravel areas on Crosley for \$16,971.16. Once you add the 10% contingency of \$5,239.72 the total will show as \$57,636.93</p>

Finance	Budgeted Item:	Yes; CIP		
	CIP #:	1260		
	TIF Info:			
	Purchase Order:	24002748	Total Encumbrance:	\$ 57,636.93

NEYRA PAVING

Neyra Paving, Inc.
10750 Evendale Drive
Cincinnati, OH 45241
513-733-1001

www.neyrapaving.com





Neyra Paving, Inc.
10750 Evendale Drive
Cincinnati, OH 45241
513-733-1001

www.neyrapaving.com

*****ALTERNATE 2*****

Description	Quantity	Unit	Unit Price	Total
ALT 2 - 1.5" MILLING	2,255	SY	\$4.95	\$11,162.25
ALT 2 - INSTALL 1.5" ASPHALT SURFACE	2,255	SY	\$10.76	\$24,263.80
Total Project Cost				\$35,426.05



Neyra Paving, Inc.
10750 Evendale Drive
Cincinnati, OH 45241
513-733-1001

www.neyrapaving.com

WEST CHESTER TOWNSHIP - VOICE OF AMERICA DRIVE

Date: 07/10/2024

Labor Type: STANDARD WAGES

Tax Exempt: TAXABLE

Plans: ATTACHED IMAGES

Dear Mr. Owens,

Neyra Paving is pleased to submit our proposal for the above referenced project. Please review the following specs. Please do not hesitate to contact [Justin Neyra](#) with any questions.

MILL ASPHALT TRANSITIONS

- a. Grind necessary butt joints to ensure a smooth transition and uniform Asphalt thickness between the old & new surfaces.

LEVEL AND RESURFACE

- a. Apply ODOT 407 Tack Coat.
- b. Furnish and install 0.5" leveling course as needed.
- c. Furnish and install 1.5" compacted, of ODOT 448 Asphalt surface.

MOBILIZATION

- a. Cost to mobilize men and Equipment



Neyra Paving, Inc.
10750 Evendale Drive
Cincinnati, OH 45241
513-733-1001

www.neyrapaving.com

Description	Quantity	Unit	Unit Price	Total
MILL ASPHALT TRANSITIONS	75	LF	\$9.57	\$717.75
LEVEL AND RESURFACE	2,255	SY	\$12.69	\$28,615.95
MOBILIZATION	1	EA	-----	Included
Total Project Cost				\$29,333.70



Neyra Paving, Inc.
10750 Evendale Drive
Cincinnati, OH 45241
513-733-1001

www.neyrapaving.com

*****ALTERNATE 1*****

ALT 1 - 4" PATCHING

- a. Excavate as required. Dispose of material offsite, as directed.
- b. Furnish and install 2" compacted, of ODOT 301 Asphalt base.
- c. Furnish and install 2" compacted, of ODOT 448 Asphalt surface.



Neyra Paving, Inc.
10750 Evendale Drive
Cincinnati, OH 45241
513-733-1001

www.neyrapaving.com

*****ALTERNATE 1*****

Description	Quantity	Unit	Unit Price	Total
ALT 1 - 4" PATCHING	57	SY	\$66.58	\$3,795.06
Total Project Cost				\$3,795.06



Neyra Paving, Inc.
10750 Evendale Drive
Cincinnati, OH 45241
513-733-1001

www.neyrapaving.com

*****ALTERNATE 2*****

ALT 2 - 1.5" MILLING

- a. Mill to a depth of 2" required. Dispose of material offsite, as directed.

ALT 2 - INSTALL 1.5" ASPHALT SURFACE

- a. Apply ODOT 407 Tack Coat.
- b. Level as required.



Neyra Paving, Inc.
 10750 Evendale Drive
 Cincinnati, OH 45241
 513-733-1001

www.neyrapaving.com

Notes:

- All work is to be completed in a workmanlike manner according to standard practices as weather permits. All work is warranted for a period of one year from date of completion. Neyra will not be responsible for cracks caused by weather conditions or ground movements, worn sealer, paving and concrete that is subjected to premature traffic.
- Neyra is not liable for water that does not drain properly on asphalt surfaces with less than 2% slope.
- Neyra is not liable for any existing surface damage that occurs due to normal construction traffic while work is being performed.
- Neyra is not responsible for damage to underground utilities.
- If Additional Mobilizations are required Neyra will add \$2,000.00 per additional requested mobilization.
- Subgrade to be provided to Neyra Paving at +/- .5" when others are performing earthwork or excavation.
- Any testing required by Neyra Paving will be an added charge.
- Project Schedule: the above proposal is based on scheduling our work Monday – Saturday.
- This proposal may be withdrawn if not accepted within 7 days. Our Suppliers have indicated to us that due to the instability of the world oil market pricing precautions need to be taken. Therefore, contracts issued after 7 days of the quote date will need to be confirmed and approved in conjunction with our suppliers.
- Any permits and/or inspection fees required by governmental agencies will be billed extra, at cost.
- Proposal excludes "staged" construction. Any maintenance and/or repairs of temporary base and/or asphalt pavement used by construction traffic will be an extra to the contract.
- All work is to be completed in a workmanlike manner according to standard practices as weather permits. All work is guaranteed to be installed as specified and is warranted for a period of one year from date of completion.
- Our work and workers are fully insured.
- Terms Net 30 days. There is a 1 1/2% per month service charge on all past due amounts.
- Neyra Paving is a Certified MBE with the Southern Ohio Minority Business Council.
- Due to fuel pricing instability fuel surcharges will apply over \$4.00 per gallon.

Exclusions: (unless included in line item pricing)

Permits	Core Samples	Testing	Bid Bound	Signage	Pipes / Utilities
Underdrain	Integral Sidewalks	Prime Coat	Performance Bond	Asphalt Patching	Fence posts & foundations
Undercuts	Geotechnical Engineer	Staking/Layout	Geotextile Fabrics	Brick Pavers	Excess Cleaning of Asphalt
Excavation			Thermoplastic Striping		Utility Location other than OUPS

Very truly yours,

Justin Neyra

NEYRA PAVING

ACCEPTANCE OF PROPOSAL - the above or attached prices and specifications are satisfactory and are hereby accepted. You are authorized to do the work as specified.

Accepted Dollar Amount

\$

Signature

Name (Please Print)

Date

/ /

V.O.A. = PAVE GRAVEL AREAS @ CROSLLEY DRIVE





Neyra Paving, Inc.
10750 Evendale Drive
Cincinnati, OH 45241
513-733-1001

www.neyrapaving.com

Description	Quantity	Unit	Unit Price	Total
MILL ASPHALT TRANSITIONS	410	LF	\$5.92	\$2,427.20
3" ASPHALT SURFACE	634	SY	\$22.94	\$14,543.96
MOBILIZATION	1	EA	-----	Included
Total Project Cost				\$16,971.16

** FIGURED TO BE COMPLETED WITH THE PAVING OF THE ENTIRE DRIVE LANE.

Neyra Paving, Inc.
 10750 Evendale Drive
 Cincinnati, OH 45241
 513-733-1001

www.neyrapaving.com

Notes:

- All work is to be completed in a workmanlike manner according to standard practices as weather permits. All work is warranted for a period of one year from date of completion. Neyra will not be responsible for cracks caused by weather conditions or ground movements, worn sealer, paving and concrete that is subjected to premature traffic.
- Neyra is not liable for water that does not drain properly on asphalt surfaces with less than 2% slope.
- Neyra is not liable for any existing surface damage that occurs due to normal construction traffic while work is being performed.
- Neyra is not responsible for damage to underground utilities.
- If Additional Mobilizations are required Neyra will add \$2,000.00 per additional requested mobilization.
- Subgrade to be provided to Neyra Paving at +/- .5" when others are performing earthwork or excavation.
- Any testing required by Neyra Paving will be an added charge.
- Project Schedule: the above proposal is based on scheduling our work Monday – Saturday.
- This proposal may be withdrawn if not accepted within 7 days. Our Suppliers have indicated to us that due to the instability of the world oil market pricing precautions need to be taken. Therefore, contracts issued after 7 days of the quote date will need to be confirmed and approved in conjunction with our suppliers.
- Any permits and/or inspection fees required by governmental agencies will be billed extra, at cost.
- Proposal excludes "staged" construction. Any maintenance and/or repairs of temporary base and/or asphalt pavement used by construction traffic will be an extra to the contract.
- All work is to be completed in a workmanlike manner according to standard practices as weather permits. All work is guaranteed to be installed as specified and is warranted for a period of one year from date of completion.
- Our work and workers are fully insured.
- Terms Net 30 days. There is a 1 1/2% per month service charge on all past due amounts.
- Neyra Paving is a Certified MBE with the Southern Ohio Minority Business Council.
- Due to fuel pricing instability fuel surcharges will apply over \$4.00 per gallon.

Exclusions: (unless included in line item pricing)

Permits	Core Samples	Testing	Bid Bound	Signage	Pipes / Utilities
Underdrain	Integral Sidewalks	Prime Coat	Performance Bond	Asphalt Patching	Fence posts & foundations
Undercuts	Geotechnical Engineer	Staking/Layout	Geotextile Fabrics	Brick Pavers	Excess Cleaning of Asphalt
Excavation			Thermoplastic Striping		Utility Location other than OUPS

Very truly yours,

Justin Neyra

NEYRA PAVING

ACCEPTANCE OF PROPOSAL - the above or attached prices and specifications are satisfactory and are hereby accepted. You are authorized to do the work as specified.

Accepted Dollar Amount \$

Signature

Name (Please Print)

Date / /



Neyra Paving, Inc.
10750 Evendale Drive
Cincinnati, OH 45241
513-733-1001

www.neyrapaving.com

WEST CHESTER TOWNSHIP - VOICE OF AMERICA DRIVE

Date: 09/20/2024

Labor Type: STANDARD WAGES

Tax Exempt: TAXABLE

Plans: ATTACHED IMAGES

Dear Mr. RANDY OWENS

Neyra Paving is pleased to submit our proposal for the above referenced project. Please review the following specs. Please do not hesitate to contact [Justin Neyra](#) with any questions.

MILL ASPHALT TRANSITIONS

- a. Grind necessary butt joints to ensure a smooth transition and uniform Asphalt thickness between the old & new surfaces.

ASPHALT SURFACE

- a. Apply ODOT 407 Tack Coat.
- b. Level as required.

MOBILIZATION

- a. Cost to mobilize men and Equipment

AGENDA ITEM COVER SHEET



Trustee Meeting Date:	Agenda Item Type:
October 8, 2024	Requisition Item
Submitted By:	
Arun Hindupur, Director of Public Works/Community Services	

Motion:
Emcor Facilities Services, Inc. - \$52,334.34 - Install parking lot lights at Muhlhauser Barn (CIP 1455)

Background:
<p>To improve safety for renters of the Muhlhauser barn, the Community Services Department created a 2024 CIP to add parking lot lights. Two additional LED lights will be added and the current light will be replaced to match the new lights.</p> <p>The Community Services Department requests a PO in the amount of \$52,334.34 which includes a 10% contingency of \$4,757.67.</p>

Finance	Budgeted Item:	Yes; CIP, TIF		
	CIP #:	1455		
	TIF Info:			
	Purchase Order:	24003009	Total Encumbrance:	\$ 52,334.34



EMCOR Facilities Services, Inc.
9655 Reading Road
Cincinnati, OH 45215
513-948-8469

September 19, 2024

Proposal # 1786

West Chester
98558 Beckett Rd
West Chester, Ohio 45069

RE: Muhlhauser barn add Streetlamps

Ms. Hayes,

EMCOR Facilities Services, Inc. has determined that our scope of activities is to be as follows.

SCOPE OF WORK:

- Provide labor and material to install two new streetlamps to match existing as close as possible. Two Poles, Type Lumec SM6F-18-BRTX, two brackets Lumec MM-2-R4-BRTX, two Anchor Bolt Lumec 3/4"-10 12-DEC and four Luminaire Lumec DMS50-72W32LED4K-G3-ACDR-LE3A-120-DMG-BRTX.
- Labor and material will include digging holes per the spec on old drawing attached, 60" deep, 24" in diameter 36" above ground exposed, pulling #8 AWG wire and conduit from existing quanzite box to one pole then to the other 18" deep. Forming and pouring concrete pole bases per spec. Set light poles, run wiring up the poles to the new heads, test and verify operation. Underground detective will be called prior to digging. Back fill and re-seed ground area where disturbed.

Material & Subs \$36,977.78
Labor \$6,174.86
Total \$43,152.64

Addendum:

- Provide labor to remove existing older head from existing pole and replace with two new heads to match the above, two Luminaire Lumec DMS50-72W32LED4K-G3-ACDR-LE3A-120-DMG-BRTX

Material & Subs \$4,029.89
Labor \$394.14
Total \$4,424.03

Total for new Poles and addendum \$47,576.67

QUALIFICATION

1. All work to be performed during normal business hours.
2. Building permits and stamped drawings are not included.
3. The price does not include any unforeseen underground issues.
4. Permitting notification and removal and/or abatement of any hazardous material are not included and shall be the responsibility of the owner. This condition could cause a stoppage of work until removal is complete and the area is certified to be free of all hazardous contaminants.
5. EMCOR Facilities Services, Inc. are not responsible for hidden conditions.
6. No other work is implied or covered.
7. This quote is valid for thirty- (30) days.
8. Tax is not included.

Thank you for the opportunity to bid on your project. If you have any questions or concerns, please contact me at 513-325-2366

Sincerely,
Jim Matthews
EMCOR Facilities Service
jmatthewsjr@emcor.net

Approved by: _____ Date: _____ PO #: _____
(PRINT NAME)
Signature: _____

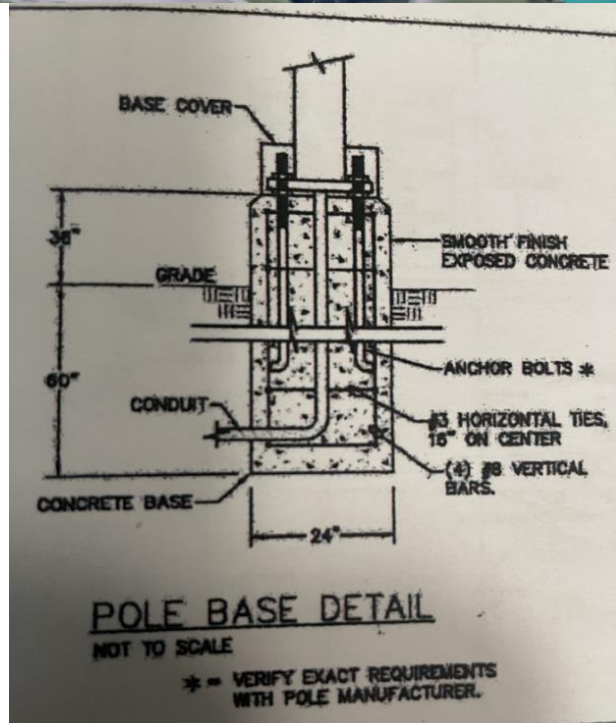
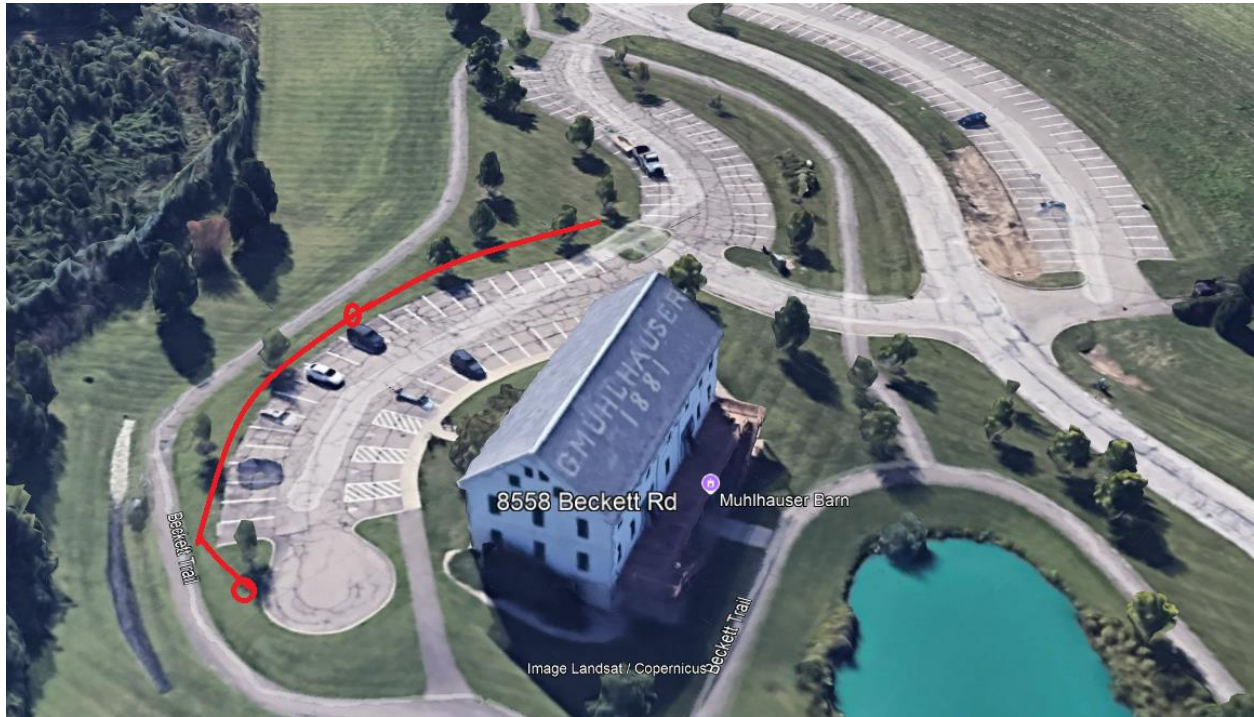

LUMEC
by Signify

Outdoor

Poles and Brackets

SM6
Round Steel Bottleneck Pole

Made from a one-piece, 4" round (102 mm) high-tensile carbon steel shaft sealed by a rolled and flattened vertical weld seam and welded over and in a 6-5/8" round (168 mm) high-tensile carbon-steel pole base. The assembly is welded to both the top and bottom of a steel anchor plate. A 4-1/2" by 10" (114 by 254 mm) maintenance opening is complete with cover and copper ground lug.

Project: _____
 Location: _____
 Cat. No: _____
 Type: _____
 Lamps: _____ Qty: _____
 Notes: _____

Ordering guide

example: SM6-F-8-DE-BE2TX

Pole Family	Wall Thickness	Nominal Height	Options	Finish	
SM6	F	20 18		BRTX	
SM6	F 0.12"	8 8'	DE Pole base buried 5' (1524 mm) in the ground	BE2TX Midnight Blue Textured	
		10 10'	LS Provision for loudspeaker outlet	BE6TX Ocean Blue Textured	
		12 12'	PH7 Button-type photoelectric cell (specify operating voltage)	BE8TX Royal Blue Textured	
		14 14'	PH8 Quarter-turn type photoelectric cell (specify operating voltage)	BG2TX Sandstone Gold Textured	
		15 15'	PH9 Shorting cap for single phase only	BKTX Black Textured	
		16 16'	DR Duplex receptacle (120V line voltage only)	BRTX Bronze Textured	
		18 18'	GFI DR with common ground fault interrupter (120V line voltage only)	GM4TX Blue Green Textured	
		20 20'	BA Banner arm	GM6TX Forest Green Textured	
		N 0.188"	8 8'	PS Plant support	GN8TX Dark Forest Green Textured
			10 10'	MPL Mid-pole luminaire	GNTX Green Textured
	12 12'			GY3TX Medium Grey Textured	
	14 14'			RD2TX Burgundy Textured	
	15 15'			RD4TX Scalet Textured	
	16 16'			WHTX White Textured	
	18 18'			GR Gray Sandtex	
	20 20'			NP Natural Alum.	
	V 0.25"		15 15'		TG Hammer-tone
			16 16'		TS Hammer-tone Silver
		18 18'			
		20 20'			

Note: The recommended method for calculating EPA (Effective Projected Area) is in accordance with AASHTO 2001 standards; for three seconds, the pole is tested in wind gusts equivalent to the strongest winds on record over the past 50 years, and with a 50 pound load (22.7 kg) placed at 1 foot (305 mm) above its center.

Outdoor Poles and Brackets

SM6 – Round Steel Bottleneck Pole

Pole Data

Pole Family	Catalog Number	Nominal Height (ft)	Nominal Height (m)	Tenon Section (in)	Tenon Section (mm)	Wall Thickness (in)	Wall Thickness (mm)	Weight (lbs)	Weight (kg)	EPA Rating 90 MPH (sq. ft.)	EPA Rating 110 MPH (sq. ft.)	EPA Rating 120 MPH (sq. ft.)	EPA Rating 150 MPH (sq. ft.)	Anchor Bolts (in)	Anchor Bolts (mm)
SM6	SM6F-8	8	2.44	4	102	0.12	3.2	85	39	30	25.3	21.31	13.78	3/4-20	19-508
SM6	SM6N-8	8	2.44	4	102	0.188	4.8	99	45	30	30	30	20.32	3/4-20	19-508
SM6	SM6F-10	10	3.05	4	102	0.12	3.2	95	43	27.44	18.5	15.53	9.98	3/4-20	19-508
SM6	SM6N-10	10	3.05	4	102	0.188	4.8	115	52	30	27.41	23.09	14.9	3/4-20	19-508
SM6	SM6F-12	12	3.66	4	102	0.12	3.2	105	48	21.2	14.12	11.79	7.52	3/4-20	19-508
SM6	SM6N-12	12	3.66	4	102	0.188	4.8	180	59	30	21.2	17.8	11.45	3/4-20	19-508
SM6	SM6F-14	14	4.27	4	102	0.12	3.2	115	52	16.82	11.04	9.13	5.79	3/4-20	19-508
SM6	SM6N-14	14	4.27	4	102	0.188	4.8	145	66	25.22	16.86	14.08	9.01	3/4-20	19-508
SM6	SM6F-15	15	4.57	4	102	0.12	3.2	120	54	15.08	9.81	8.07	5.06	3/4-20	19-508
SM6	SM6N-15	15	4.57	4	102	0.188	4.8	153	69	22.76	15.14	12.61	8.04	3/4-20	19-508
SM6	SM6V-15	15	4.57	4	102	0.25	6.4	182	83	30	20.9	17.5	11.24	3/4-20	19-508
SM6	SM6F-16	16	4.88	4	102	0.12	3.2	125	57	13.62	8.75	7.16	4.46	3/4-20	19-508
SM6	SM6N-16	16	4.88	4	102	0.188	4.8	161	73	20.71	13.67	11.35	7.21	3/4-20	19-508
SM6	SM6V-16	16	4.88	4	102	0.25	6.4	192	87	28.34	19.01	15.89	10.18	3/4-20	19-508
SM6	SM6F-18	18	5.49	4	102	0.12	3.2	135	61	10.83	6.75	5.43	3.3	3/4-27	19-686
SM6	SM6N-18	18	5.49	4	102	0.188	4.8	176	80	16.78	10.88	8.95	5.61	3/4-27	19-686
SM6	SM6V-18	18	5.49	4	102	0.25	6.4	212	96	23.17	15.36	12.76	8.13	3/4-27	19-686
SM6	SM6F-20	20	6.1	4	102	0.12	3.2	145	66	8.64	5.14	4.03	2.37	3/4-27	19-686
SM6	SM6N-20	20	6.1	4	102	0.188	4.8	191	87	13.7	8.68	7.05	4.35	3/4-27	19-686
SM6	SM6V-20	20	6.1	4	102	0.25	6.4	232	105	19.12	12.49	10.3	6.49	3/4-27	19-686

Specifications

Joint cover

Made from two pieces of cast aluminum mechanically fastened to the junction with stainless steel hardware.

Base cover

Decorative base cover made from cast-aluminum pieces mechanically assembled together with stainless steel hardware around base of the pole.

Finish

Color to be in accordance with the AAMA 2603 standard. Application of polyester powder coat paint (4 mils/100 microns) with ± 1 mils/24 microns of tolerance. The Thermosetting resins provides a discoloration resistant finish in accordance with the ASTM D2244 standard, as well as luster retention in keeping with the ASTM D523 standard and humidity proof in accordance with the ASTM D2247 standard.

Outdoor Poles and Brackets

SM6 – Round Steel Bottleneck Pole

Dimensions

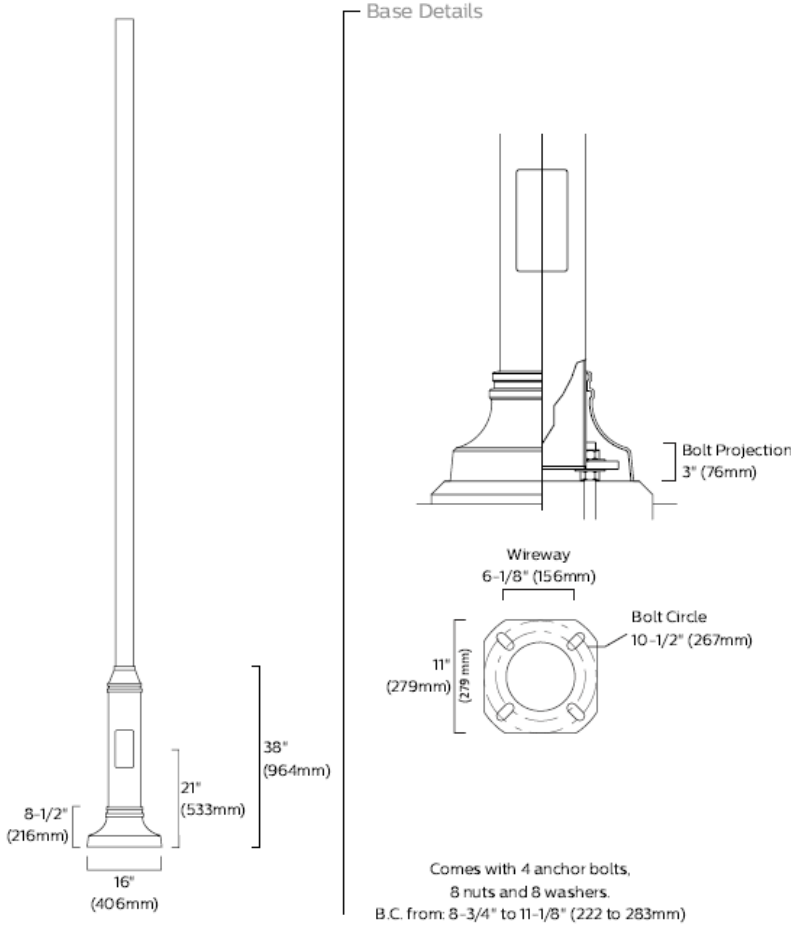

MM / MR / MT / UM > MEDIUM REACH BRACKETS

MM

EPA: 2.32 sq.ft. Weight: 22.0 lbs. (10.0 kg)

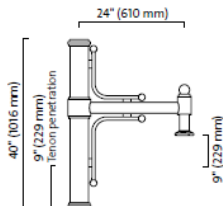

Specifications:

The **MM** mounting arm features a 2 3/8" round (60 mm) extruded-aluminum arm welded to an aluminum central pole adaptor.

The mounting arm includes two decorative cast-aluminum bent rods.

The luminaire adaptor will accept a luminaire equipped with Lumec's four-bolt mounting system.

The aluminum central pole adaptor slip-fits 9" (229 mm) over a 4" (102 mm), 5" (127 mm) or 5 9/16" (141 mm) O.D. pole or tenon.

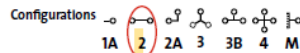



Domus 50 is one of the most versatile luminaires offered by Lumecc. This classic shape was one of the first in a line of pioneering Lumecc designs. **Domus** offers a subtly refined design that balances shape, dimension and proportion.

Project: _____
Location: _____
Cat. No: _____
Type: _____
Lamps: _____ Qty: _____
Notes: _____

Ordering guide

Example: DMS50-90W80LED4K-T-ACDR-LE3F-120-DMG-SMB-RCD-PH8-BKTX

Series	LED module	Gen	Globe material	Optical system	Voltage	Driver options
DMS50	72W32LED4K	G3	ACDR	LE3A	120	DMG
DMS50 Domus	4000K 3000K 35W32LED4K 35W32LED3K 55W32LED4K 55W32LED3K 55W48LED4K 55W48LED3K 70W64LED4K 70W64LED3K 72W32LED4K 72W32LED3K 80W48LED4K 80W48LED3K 90W80LED4K 90W80LED3K 108W48LED4K 108W48LED3K 110W64LED4K 110W64LED3K 135W80LED4K 135W80LED3K 145W64LED4K 145W64LED3K 180W80LED4K 180W80LED3K	G3	ACDR Acrylic globe	Globe LE2A ⁶ Type II (ASYM) with globe LE3A ⁶ Type III (ASYM) with globe LE4A ⁶ Type IV (ASYM) with globe Sag lens LE2S Type II (ASYM) Sag glass lens LE3S Type III (ASYM) Sag glass lens LE4S Type IV (ASYM) Sag glass lens LE5S ¹ Type V (SYMM) Sag glass lens Flat lens LE2F Type II (ASYM) Flat glass lens LE3F Type III (ASYM) Flat glass lens LE4F Type IV (ASYM) Flat glass lens LE5F ¹ Type V (SYMM) Flat glass lens	120 120V 208 208V 240 240V 277 277V 347 347V 480 480V	AST ³ Pre-set, progressive start-up CLO ³ Pre-set, manage lumen depreciation DALI ³ Pre-set, compatible with the DALI control system OTL ³ Pre-set to signal end of life of the lamp DMG 0-10V CDMGE25 ³ 8 hrs. 25% reduction CDMGE50 ³ 8 hrs. 50% reduction CDMGE75 ³ 8 hrs. 75% reduction CDMG25 ³ 6 hrs. 25% reduction CDMG50 ³ 6 hrs. 50% reduction CDMG75 ³ 6 hrs. 75% reduction CDMG525 ³ 4 hrs. 25% reduction CDMG550 ³ 4 hrs. 50% reduction CDMG575 ³ 4 hrs. 75% reduction SRD ³ Sensor ready driver, standard configuration SRD1 ³ Sensor ready driver, alternate configuration

Ordering guide (continued)

Adaptors	Luminaire options	Poles & Brackets	Finish
<input type="checkbox"/>	<input type="checkbox"/>	<input type="checkbox"/>	BRTX
MA1 1 1/4" NPT threaded hole adaptor MA2 1 1/2" NPT threaded hole adaptor SMA ⁷ Decorative retro side-mounted cast-	BO Bridge and Overpass DE1 Decorative deflector HS House side shield PH7 Photoelectric cell, bottom type PH8 ^{2,4} Photoelectric cell	Consult signify.com/outdoorluminaires for details and the complete line of Signify	BE2TX Textured midnight blue BE6TX Textured ocean blue BE8TX Textured royal blue BG2TX Textured Sandstone BKTX Textured black BRTX Textured bronze

Footnotes

1. Not available with HS option.
2. SMA or SMB adaptors is required for this option.
3. Not available 347-480 volt.
4. Luminaire option RC, RCD or RCD1 is required with this options.

DMS50 Domus LED Pendant

Urban Luminaire

Dimensions

EPA: 1.35 ft² max.
 Weight: 42 lbs (19.1kg) max.

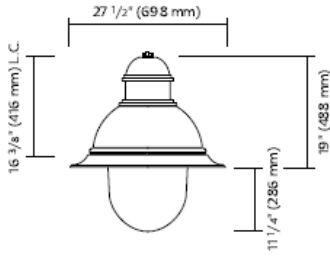

DMS50 - A optics
 Long drop globe

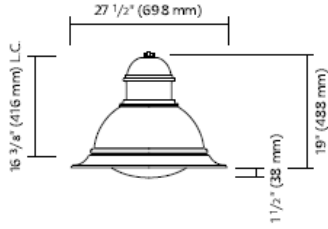

DMS50 - S optics
 Sag lens

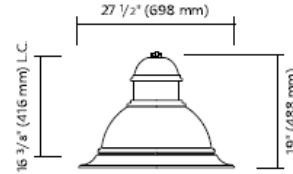

DMS50 - F optics
 Flat lens

Predicted Lumen Depreciation Data

Predicted performance derived from LED manufacturer's data and engineering design estimates, based on IESNA LM-80 methodology. Actual experience may vary due to field application conditions. L₇₀ is the predicted time when LED performance depreciates to 70% of initial lumen output. Calculated per IESNA TM21-11. Published L₇₀ hours limited to 6 times actual LED test hours.

Ambient Temperature °C	Driver mA	Calculated L ₇₀ Hours	L ₇₀ per TM-21	Lumen Maintenance % at 60,000 hrs
35°C	700 mA	>100,000 hours	>60,000 hours	>86%

DMS50 Domus LED Pendant

Urban Luminaire

LED Wattage and Lumen Values: for DMS55 @ 4000K

Ordering Code:	Total LEDs	LED current (mA)	Average System Wattage (W)	Lumen Output	BUG Rating	Efficacy (LPW)	Lumen Output	BUG Rating	Efficacy (LPW)	Lumen Output	BUG Rating	Efficacy (LPW)	Lumen Output	BUG Rating	Efficacy (LPW)
Flat Lens 4000K															
				LE2F			LE3F			LE4F			LE5F		
35W32LED4K-G3-x	32	350	37	5304	143	B1-U0-G1	5241	141	B1-U0-G1	5201	140	B1-U0-G1	5171	139	B3-U0-G1
55W32LED4K-G3-x	32	530	55	7627	139	B2-U0-G1	7537	137	B2-U0-G2	7479	136	B1-U0-G2	7436	135	B3-U0-G2
72W32LED4K-G3-x	32	700	72	9602	133	B2-U0-G1	9488	132	B2-U0-G2	9416	131	B2-U0-G2	9362	130	B3-U0-G2
55W48LED4K-G3-x	48	350	54	7933	148	B2-U0-G2	7839	146	B2-U0-G2	7779	145	B2-U0-G2	7734	144	B4-U0-G2
80W48LED4K-G3-x	48	530	80	11347	142	B2-U0-G2	11213	140	B2-U0-G2	11128	139	B2-U0-G2	11063	138	B4-U0-G2
108W48LED4K-G3-x	48	700	105	14251	136	B3-U0-G2	14082	134	B2-U0-G2	13975	133	B2-U0-G2	13894	132	B4-U0-G2
70W64LED4K-G3-x	64	350	69	10316	149	B3-U0-G2	10194	147	B2-U0-G2	10117	146	B2-U0-G2	10058	145	B4-U0-G2
110W64LED4K-G3-x	64	530	105	14788	140	B3-U0-G2	14613	139	B3-U0-G2	14502	138	B2-U0-G2	14418	137	B4-U0-G2
145W64LED4K-G3-x	64	700	138	18579	135	B3-U0-G2	18359	133	B3-U0-G2	18219	132	B2-U0-G2	18114	131	B4-U0-G2
90W80LED4K-G3-x	80	350	86	12877	150	B3-U0-G2	12724	148	B3-U0-G2	12628	147	B3-U0-G3	12555	146	B4-U0-G2
135W80LED4K-G3-x	80	530	131	18395	141	B3-U0-G3	18177	139	B3-U0-G2	18039	138	B3-U0-G3	17935	137	B5-U0-G3
180W80LED4K-G3-x	80	700	174	22958	132	B3-U0-G3	22686	130	B3-U0-G3	22514	129	B3-U0-G3	22384	128	B5-U0-G3
Sag Lens 4000K															
				LE2S			LE3S			LE4S			LE5S		
35W32LED4K-G3-x	32	350	37	5370	145	B1-U0-G1	5322	143	B1-U0-G1	5315	143	B1-U0-G1	5358	144	B3-U0-G1
55W32LED4K-G3-x	32	530	55	7721	140	B2-U0-G1	7653	139	B1-U0-G2	7643	139	B1-U0-G2	7704	140	B3-U0-G2
72W32LED4K-G3-x	32	700	72	9721	135	B2-U0-G1	9634	134	B2-U0-G2	9623	134	B2-U0-G2	9699	135	B4-U0-G2
55W48LED4K-G3-x	48	350	54	8031	150	B2-U0-G2	7960	149	B2-U0-G2	7950	148	B1-U0-G2	8013	149	B3-U0-G2
80W48LED4K-G3-x	48	530	80	11488	144	B2-U0-G2	11386	142	B2-U0-G2	11372	142	B2-U0-G2	11462	143	B4-U0-G2
108W48LED4K-G3-x	48	700	105	14427	137	B3-U0-G2	14299	136	B2-U0-G2	14281	136	B2-U0-G2	14395	137	B4-U0-G2
70W64LED4K-G3-x	64	350	69	10444	150	B3-U0-G2	10351	149	B2-U0-G2	10338	149	B2-U0-G2	10421	150	B4-U0-G2
110W64LED4K-G3-x	64	530	105	14971	142	B3-U0-G2	14838	141	B2-U0-G2	14819	141	B2-U0-G2	14937	142	B4-U0-G2
145W64LED4K-G3-x	64	700	138	18809	136	B3-U0-G2	18642	135	B2-U0-G2	18619	135	B3-U0-G3	18767	136	B5-U0-G3
90W80LED4K-G3-x	80	350	86	13037	152	B3-U0-G2	12921	151	B3-U0-G3	12905	150	B2-U0-G2	13007	152	B4-U0-G2
135W80LED4K-G3-x	80	530	131	18623	143	B3-U0-G3	18457	141	B3-U0-G3	18435	141	B3-U0-G3	18581	142	B4-U0-G2
180W80LED4K-G3-x	80	700	174	23243	133	B3-U0-G3	23036	132	B3-U0-G3	23008	132	B3-U0-G4	23190	133	B5-U0-G3
Prism Globe 4000K															
				LE2A			LE3A			LE4A					
35W32LED4K-G3-x	32	350	37	5335	144	B1-U3-G1	5294	143	B1-U3-G2	5309	143	B1-U3-G2	--	--	--
55W32LED4K-G3-x	32	530	55	7672	139	B2-U3-G2	7613	138	B2-U3-G2	7635	139	B2-U3-G2	--	--	--
72W32LED4K-G3-x	32	700	72	9658	134	B2-U3-G2	9585	133	B2-U3-G2	9612	134	B2-U3-G3	--	--	--
55W48LED4K-G3-x	48	350	54	7979	149	B2-U3-G2	7919	148	B2-U3-G2	7941	148	B2-U3-G2	--	--	--
80W48LED4K-G3-x	48	530	80	11414	143	B2-U3-G2	11327	142	B2-U3-G3	11359	142	B2-U3-G3	--	--	--
108W48LED4K-G3-x	48	700	105	14334	137	B3-U3-G3	14225	135	B3-U3-G3	14265	136	B2-U3-G3	--	--	--
70W64LED4K-G3-x	64	350	69	10377	150	B2-U3-G2	10298	148	B2-U3-G2	10327	149	B2-U3-G3	--	--	--
110W64LED4K-G3-x	64	530	105	14874	141	B3-U3-G3	14761	140	B3-U3-G3	14803	140	B2-U3-G3	--	--	--
145W64LED4K-G3-x	64	700	138	18688	135	B3-U3-G3	18546	134	B3-U3-G3	18598	135	B3-U3-G4	--	--	--
90W80LED4K-G3-x	80	350	86	12952	151	B3-U3-G3	12854	150	B2-U3-G3	12890	150	B2-U3-G3	--	--	--
135W80LED4K-G3-x	80	530	131	18503	142	B3-U3-G3	18362	141	B3-U3-G3	18413	141	B3-U3-G4	--	--	--
180W80LED4K-G3-x	80	700	174	23093	133	B3-U3-G3	22917	132	B3-U3-G3	22981	132	B3-U3-G4	--	--	--

Actual performance may vary due to installation variables including optics, mounting/ceiling height, dirt depreciation, light loss factor, etc.; highly recommended to confirm performance with a layout - contact Applications at signify.com/outdoorluminaire.
Note: Some data may be scaled based on tests of similar. But not identical luminaires.

DMS50 Domus LED Pendant

Urban Luminaire

Specifications:

LED engine

LED type: Lumileds LUXEON T. Composed of high-performance white LEDs. Color temperature as per ANSI/NEMA bin Neutral White, 4000 Kelvin nominal (3985K +/- 275K or 3710K to 4260K) or Warm white, 3000 Kelvin nominal (3045K +/- 175K or 2870K to 3220K), CRI 70 Min. 75 Typical.

Lens

LExF/LExS: Made of soda lime tempered glass lens, mechanically assembled and sealed onto the lower part of the heat sink.

LExA (Globe): Made of one-piece seamless injection-molded impact-resistant (DR) acrylic having an inner prismatic surface. The globe is mechanically assembled and sealed onto the lower part of the heat sink.

Heat sink

Made of cast aluminum optimizing the LEDs efficiency and life. Product does not use any cooling device with moving parts (only passive cooling device).

Driver

Driver comes standard with dimming compatible 0-10V. High power factor of 95%. Electronic driver, operating range 50/60 Hz. Auto adjusting universal voltage input from 120 to 277 VAC rated for both application line to line or line to neutral, Class I, THD of 20% max. Maximum ambient operating temperature from 40F(40C) to 130F(55C) degrees. Certified in compliance to UL1310 cULus requirement. Dry and damp location. Assembled on a unitized removable tray with Tyco quick disconnect plug resisting to 221F(105C) degrees. The current supplying the LEDs will be reduced by the driver if the driver experiences internal overheating as a protection to the LEDs and the electrical components. Output is protected from short circuits, voltage overload and current overload. Automatic recovery after correction. Standard built in driver surge protection of 2.5kV (min).

Optical system

Composed of high performance optical grade PMMA acrylic refractor lenses to achieve desired distribution optimized to get maximum spacing, target lumens and a superior lighting

Prismatic globe: IP66 rated optical system, composed of individual pre-oriented lens to achieve desired distribution, assembled with globe having an inner prismatic surface permanently sealed onto the lower part of the heat sink.

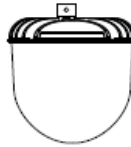

LE2A - Type II (ASYM) with globe (ACDR)
LE3A - Type III (ASYM) with globe (ACDR)
LE4A - Type IV (ASYM) with globe (ACDR)

Sag lens: IP66 rated optical system, composed of individual pre-oriented lens to achieve desired distribution, assembled with a tempered-glass sag lens permanently sealed onto the lower part of the heat sink.



LE2S - Type II (ASYM) Sag glass lens
LE3S - Type III (ASYM) Sag glass lens
LE4S - Type IV (ASYM) Sag glass lens
LE5S - Type V (SYMM) Sag glass lens

Flat lens: IP66 rated optical system, composed of individual pre-oriented lens to achieve desired distribution, assembled with a tempered-glass flat lens permanently sealed onto the lower part of the heat sink.



LE2F - Type II (ASYM) Flat glass lens
LE3F - Type III (ASYM) Flat glass lens
LE4F - Type IV (ASYM) Flat glass lens
LE5F - Type V (SYMM) Flat glass lens

DMG: Dimmable driver 0-10V.

CDMG: Dynadimmer standard dimming functionalities including pre-programmed scenarios to suit many applications and needs from safety to maximum energy savings.

Ordering Code	Scenario	Dimming Time	Dimming Level
CDMGS25	Safety	4 hours	25% power
CDMGS50	Safety	4 hours	50% power
CDMGS75	Safety	4 hours	75% power
CDMGM25	Median	6 hours	25% power
CDMGM50	Median	6 hours	50% power
CDMGM75	Median	6 hours	75% power
CDMGE25	Economy	8 hours	25% power
CDMGE50	Economy	8 hours	50% power
CDMGE75	Economy	8 hours	75% power

SRD: Sensor Ready Driver including SR communication (used for dimming and other functionalities), 24V auxiliary supply and a logical signal input (LSI) connected to the top NEMA twist lock receptacle.

SRD1: Sensor Ready Driver including SR communication (used for dimming and other functionalities) but with 24V auxiliary supply and a logical signal input (LSI) not connected to the top NEMA twist lock.

Surge protector

Surge protector tested in accordance with ANSI/IEEE C62.45 per ANSI/IEEE C62.41.2 Scenario I Category C High Exposure 10kV/10kA waveforms for Line Ground, Line Neutral and Neutral Ground, and in accordance with U.S. DOE (Department of Energy) MSSLC (Municipal Solid State Street Lighting Consortium) model specification for LED roadway luminaires electrical immunity requirements for High Test Level 10kV / 10kA. **SP2** 20kV/20kA optional.

Luminaire adaptor

MAI: The luminaire is suspended by means of a mounting adaptor with a 1/2" (32mm) NPT threaded hole accepting a threaded tube from the mounting. Retrofit adaptor for existing mounting



AGENDA ITEM COVER SHEET



Trustee Meeting Date:	Agenda Item Type:
October 8, 2024	Business Item
Submitted By:	
LtC. Brian Rebholz, Interim Chief of Police	

Motion:
Motion not to object to a new D3 liquor permit for Pho Pham LLC dba Tasty Pho 7741 Tylers Place Boulevard

Background:

Finance	Budgeted Item:	N/A;		
	CIP #:			
	TIF Info:			
	Purchase Order:		Total Encumbrance:	\$.00

**NOTICE TO LEGISLATIVE
AUTHORITY**

OHIO DIVISION OF LIQUOR CONTROL
 6406 TUSSING ROAD, P.O. BOX 4005
 REYNOLDSBURG, OHIO 43088-9005
 (614)844-2380 FAX(614)644-3168

TO

6878299		NEW	PHO PHAM LLC DBA TASTY PHO 7741 TYLERS PLACE BLVD WEST CHESTER TWP WEST CHESTER OH 45069
PERMIT NUMBER		TYPE	
08 14 2024			
ISSUE DATE			
09 948 A		E26197	
PERMIT CLASSES		RECEIPT NO.	
TAX DISTRICT			

FROM 08/30/2024

PERMIT NUMBER		TYPE
ISSUE DATE		
FILING DATE		
PERMIT CLASSES		
TAX DISTRICT		RECEIPT NO.



MAILED 08/30/2024

RESPONSES MUST BE POSTMARKED NO LATER THAN. 09/30/2024

IMPORTANT NOTICE

PLEASE COMPLETE AND RETURN THIS FORM TO THE DIVISION OF LIQUOR CONTROL
WHETHER OR NOT THERE IS A REQUEST FOR A HEARING.

REFER TO THIS NUMBER IN ALL INQUIRIES A NEW 6878299

(TRANSACTION & NUMBER)

(MUST MARK ONE OF THE FOLLOWING)

WE REQUEST A HEARING ON THE ADVISABILITY OF ISSUING THE PERMIT AND REQUEST THAT
 THE HEARING BE HELD IN OUR COUNTY SEAT. IN COLUMBUS.

WE DO NOT REQUEST A HEARING.

DID YOU MARK A BOX? IF NOT, THIS WILL BE CONSIDERED A LATE RESPONSE.

PLEASE SIGN BELOW AND MARK THE APPROPRIATE BOX INDICATING YOUR TITLE:

(Signature)

(Title)- Clerk of County Commissioner

(Date)

Clerk of City Council

Township Fiscal Officer

WEST CHESTER TOWNSHIP TRUSTEE
 ATTN TOWNSHIP FISCAL OFFICER
 9113 CINCINNATI DAYTON RD
 WEST CHESTER OHIO 45069



WEST CHESTER POLICE DEPARTMENT LIQUOR PERMIT INVESTIGATION

[Handwritten Signature]
08/20/24

Date application received: <u>9/17/24</u>		Report date: <u>9/19/24</u>	
6878299 Liquor Permit Number		NEW Type of Permit Requested	
Applicant 1: <u>Tu Ha Pham</u> Name <u>4624 Hastings Dr.</u> Address <u>Dayton OH 45440</u> City, State, Zip Code		Local law enforcement history: No local history	
Applicant 1: <u>Vy Trang Nguyen</u> Name <u>4624 Hastings Dr.</u> Address <u>Dayton OH 45440</u> City, State, Zip Code		Local law enforcement history: No local history	
Applicant 1: _____ Name _____ Address _____ City, State, Zip Code		Local law enforcement history:	
Applicant 1: _____ Name _____ Address _____ City, State, Zip Code		Local law enforcement history:	

Description of projected location: **7741 Tylers Place Blvd is located on the North West corner of Tylers Place Blvd and Tylers Corner Dr. The location is in a strip of businesses.**

Diagram/Map attached: Yes

Description of projected business operation: **According to Mr. Pham, Tasty Pho will continue as an Asian inspired restaurant and will continue to offer/serve beer, wine and spirits (when all the required permits are obtained) as part of their menu.**

Handwritten initials/signature

Public institutions within 500 feet of projected site (May object to permit issue) ex. Schools, Churches, Libraries, Public Playgrounds and Township Parks Additional Institutions should be listed in the investigator's narrative.	
1. N/A	
Name of Institution	Distance
2.	
Name of Institution	Distance
3.	
Name of Institution	Distance

Impact on surrounding business: **No impact projected on the surrounding area.**

Investigator's narrative: **I spoke to Tu Pham one of the owners and liquor permit applicants. He was polite and forthcoming with information. He explained he recently took over from the previous owner and originally had transferred their permit through the State. He then became aware that he failed to renew and the permit lapsed. He was required to file for a new permit but the D3 is the only permit available at this time. He plans on adding to that in the future. The restaurant will continue to operate exactly the way it has for that last several years. It will feature an Asian inspired menu. The maximum occupancy remains 104 and the square footage is 3109 sq. ft. Roughly ten employees will work there. None of which are under 21 years old. The hours of operation are still seven days a week 11am-9pm. He does not have other similar businesses or liquor permits.**

There are no concerns that the approval of this permit will have an adverse effect on public safety efforts. I see no reason to object to this application for D3 (Spirituous liquor for on premises consumption only until 1:00am) liquor permit.

Objecting to Liquor Permit? No If yes, please explain reason for objection:

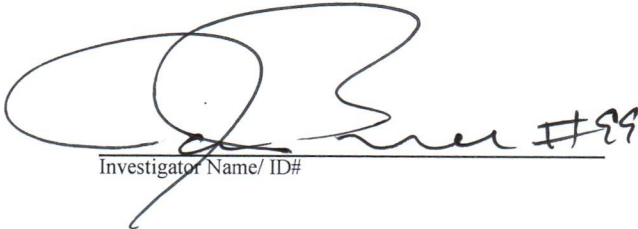
Investigator Name/ ID#

§ 4303.292. Grounds for refusal to issue, transfer or renew permit

(A) The division of liquor control may refuse to issue, transfer the ownership of, or renew, and shall refuse to transfer the location of any retail permit issued under this chapter if it finds:

(1) That the applicant, any partner, member, officer, director, or manager thereof, or any shareholder owning ten per cent or more of its capital stock:

(a) Has been convicted at any time of a crime which relates to fitness to operate a liquor establishment;

(b) Has operated liquor permit businesses in a manner that demonstrates a disregard for the laws, regulations, or local ordinances of this state or any other state;

(c) Has misrepresented a material fact in applying to the division for a permit;

(d) Is in the habit of using alcoholic beverages or dangerous drugs to excess, or is addicted to the use of narcotics.

(2) That the place for which the permit is sought:

(a) Does not conform to the building, safety, or health requirements of the governing body of the county or municipality in which the place is located. As used in division (A)(2)(a) of this section, "building, safety, or health requirements" does not include local zoning ordinances. The validity of local zoning regulations shall not be affected by this section.

(b) Is so constructed or arranged that law enforcement officers and duly authorized agents of the division are prevented from reasonable access to rooms within which beer or intoxicating liquor is to be sold or consumed.

(c) Is so located with respect to the neighborhood that substantial interference with public decency, sobriety, peace, or good order would result from the issuance, renewal, transfer of location, or transfer of ownership of the permit and operation thereunder by the applicant.

(d) Has been declared a nuisance pursuant to Chapter 3767. of the Revised Code since the time of the most recent issuance, renewal, or transfer of ownership or location of the liquor permit.

(B) The division of liquor control may refuse to issue or transfer the ownership of, and shall refuse to transfer the location of any retail permit issued under this chapter if it finds:

(1) That the place for which the permit is sought is so situated with respect to any school, church, library, public playground, or hospital that the operation of the liquor establishment will substantially and adversely affect or interfere with the normal, orderly conduct of the affairs of those facilities or institutions.

(2) That the number of permits already existent in the neighborhood is such that the issuance or transfer of location of a permit would be detrimental to and substantially interfere with the morals, safety, or welfare of the public, and, in reaching a conclusion in this respect, the division shall consider, in light of the purposes of Chapters 4301., 4303., and 4399. of the Revised Code, the character and population of the neighborhood, the number and location of similar permits in

the neighborhood, the number and location of all other permits in the neighborhood, and the effect the issuance or transfer of location of a permit would have on the neighborhood.

(C) The division of liquor control shall not transfer the location or transfer the ownership and location of a permit under division (B)(3)(b) of section 4303.29 of the Revised Code unless the permit is transferred to an economic development project.

(D) The division of liquor control shall refuse to issue, renew, transfer the ownership of, or transfer the location of a retail permit under this chapter if the applicant is or has been convicted of a violation of division (C)(1) of section 2913.46 of the Revised Code.

(E) The division of liquor control shall refuse to transfer the ownership of or transfer the location of a retail permit under this chapter while criminal proceedings are pending against the holder of the permit for a violation of division (C)(1) of section 2913.46 of the Revised Code. The department of job and family services shall notify the division of liquor control whenever criminal proceedings have commenced for a violation of division (C)(1) of section 2913.46 of the Revised Code.

(F) The division shall refuse to issue, renew, or transfer the ownership or location of a retail permit under this chapter if the applicant has been found to be maintaining a nuisance under section 3767.05 of the Revised Code at the premises for which the issuance, renewal, or transfer of ownership or location of the retail permit is sought.

Tasty Pho, 7741 Tylers Place Blvd.



Tasty Pho, 7741 Tylers Place Blvd.

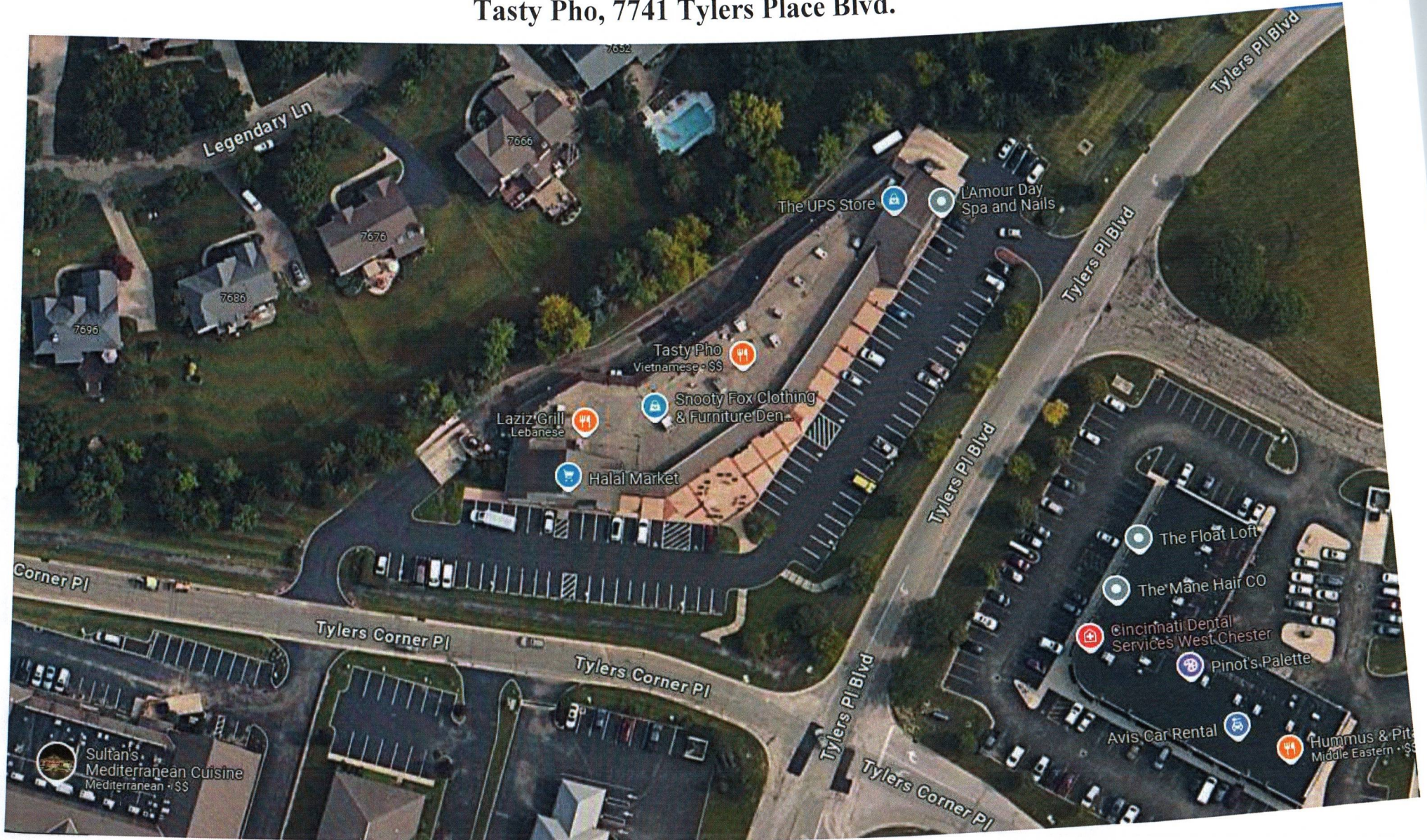

AGENDA ITEM COVER SHEET



Trustee Meeting Date:	Agenda Item Type:
October 8, 2024	Resolution Item
Submitted By:	
Katy Kanelopoulos, Director of Community Development	

Motion:
Resolution 38-2024 approving Major Change for Case #MC 05-24 The Gateway of West Chester; Site D

Background:
The applicant is requesting a Major Change to the PUD to include a 4,824 s.f. fuel station/convenient store and a 3600 s.f. multi-tenant building with outdoor seating on 4.131 acres located along Imagination Blvd. Parcel #: M5620-027-000-112

Finance	Budgeted Item:	N/A;	
	CIP #:		
	TIF Info:		
	Purchase Order:		Total Encumbrance:

RESOLUTION NO. 38-2024

Resolution approving a Major Change to the North Point-Streets North - The Gateway of West Chester SP-PUD (Special Purpose Planned Unit Development District) and Preliminary Development Plan for Site D Case #MC 05-24

WHEREAS, on September 22, 2021, the West Chester Township Board of Trustees approved a Zoning Map Amendment from CBD (Central Business District) to SP-PUD (Special Purpose Planned Unit Development District) and a Preliminary Development Plan (15-2021) for approximately 497,000 square feet of commercial use, 870 multi-family units, and a 140 room hotel (Sites A-O) on approximately 98.6 acres; and,

WHEREAS, on November 21, 2022, the West Chester Township Zoning Commission recommended denial for a Phase 2, Final Development Plan (22-13) (Site D) for a 6,369 square foot fueling station and convenience store and a 3,500 square foot carwash on 4.13 acres; and,

WHEREAS, on April 17, 2023, the West Chester Township Zoning Commission recommended denial for a Phase 2, Final Development Plan (23-4) (Site D) for a 6,369 square foot fueling station and convenience store and a 3,500 square foot carwash on 4.13 acres; and,

WHEREAS, both of the aforementioned applications were withdrawn prior to the Board of Trustees hearings based on the previous recommendations; and,

WHEREAS, on June 17, 2024, the West Chester Township Zoning Commission recommended denial for a Major Change and Preliminary Development Plan for the previously approved Site D (24-11) for a 4,650 square foot fueling station and convenience store on 2.42 acres and a 2,300 square foot drive-thru restaurant with outdoor seating on 1.71 acres; and,

WHEREAS, the aforementioned application was withdrawn prior to the Board of Trustees hearings based on the previous recommendations; and,

WHEREAS, on July 15, 2024, United Properties Development, LLC. submitted an application requesting a Major Change and Preliminary Development Plan for the previously approved Site D for a 4,824 square foot fueling station and convenience store on 2.42 acres and a 3,600 square foot, multi-tenant retail building with outdoor seating on 1.71 acres; and,

WHEREAS, on August 13, 2024, the Butler County Planning Commission conducted a public hearing for the aforesaid application and recommended approval; and,

WHEREAS, on August 19, 2024, the West Chester Township Zoning Commission conducted a public hearing for the aforesaid application recommended approval; and,

WHEREAS, by advertisement, a public hearing for the aforesaid application was conducted before the West Chester Township Board of Trustees on September 9, 2024, as applied for by United Properties Development, LLC; and,

WHEREAS, the West Chester Township Board of Trustees passed a motion to continue the public hearing to October 8, 2024; and,

WHEREAS, by advertisement, a public hearing for the aforesaid application was conducted before the West Chester Township Board of Trustees on October 8, 2024, as applied for by United Properties Development, LLC; and,

WHEREAS, all those present for the hearing who wished to be heard voiced their opinions with respect thereto; and,

NOW THEREFORE, BE IT RESOLVED that on the basis of the above actions and findings, the West Chester Township Board of Trustees hereby approve the Major Change to the existing SP-PUD (Special Purpose Planned Unit Development District) and Preliminary Development Plan with the following conditions:

SECTION 1. If not specifically conditioned with an approval of this Major Change and PDP, all subsequent Final Development Plan (FDP) applications shall otherwise remain subject to the conditions as previously and last approved (Trustee Resolution 15-2021).

SECTION 2. With the recommended approval of an additional multi-tenant retail/ restaurant use on the subject site, previously approved Site D, only two (2) more sites on the previously approved Sites H, I and J shall be permitted to be retail/ drive-thru restaurant uses.

SECTION 3. Detailed site civil engineering plans, including grading plans and stormwater drainage plans and calculations, shall be coordinated with the BCEO at the FDP stage to include the following:

- a.) Vehicular access to both lots will only be permitted from Imagination Way;
- b.) A truck-turning template will need to be used to ensure maneuverability of larger trucks;
- c.) A sight distance study will be required along the cross-access way and Imagination Way;
- d.) Consideration should be given for a direct outlet of the drive-thru to the proposed cross-access way; and
- e.) Clarification is required for any proposed work in the right-of-way.

SECTION 4. Detailed water and sanitary sewer main installation and sanitary lateral plans shall be coordinated with the Butler County Water and Sewer Department at the FDP stage.

SECTION 5. The applicant shall coordinate with the West Chester Township Fire Department (WCTFD) at the permitting stage in regard to access ways and internal roadways; connections and locations of fire hydrants; fire lane requirements; and all other applicable building and fire codes, to specifically include the following:

- a.) All permits, testing and inspection of underground fuel tanks shall go through the State Fire Marshall's Bureau (BUSTR);
- b.) Applicant shall confirm 24-hour operations and attendance of fuel station pumps, to determine if a canopy fire suppression system is needed;
- c.) "No Parking" fire lanes shall be coordinated with the FD;
- d.) Underground fire main will be required to be looped through the site; and
- e.) All drive aisles will need to meet safety service vehicle turning radius requirements.

SECTION 6. The Any relocation of street lights (and associated cost) to accommodate the development will be the responsibility of the developer/contractor.

SECTION 7. The site perimeter sidewalks/ crosswalks located within the public right-of-way shall be constructed as required by the BCEO, in regard to the public design standards and for materials and compaction.

SECTION 8. Any amplified sound is prohibited from the outdoor seating area.

SECTION 9. Internally-illuminated building signage shall be prohibited from any north building wall or canopy side.

SECTION 10. One (1) ground-mounted monument sign shall be permitted on each lot at a maximum of eight (8) foot in height and forty-eight (48) square feet of display area and subject to all other requirements of Article 20 standards for ground signs.

SECTION 11. A landscaping plan, which illustrates consistency with the preliminary landscaping plan shall be illustrated on the FDP.

SECTION 12. The property owner shall be responsible for keeping all common features and elements well maintained and free from trash and litter; maintaining the private road; all drainage ways to ensure the detention areas perform the designated function; and all landscaping shall be well maintained in good condition and all major landscaping shall be irrigated with a permanent system prior to a final zoning inspection.

SECTION 13. The temporary construction access and vehicle staging area shall be coordinated with the BCEO and WCT prior to the issuance of a zoning certificate, which shall be designed to support all construction traffic in all weather conditions. All roadways to access the site shall be maintained free of any dirt, debris, dust, etc., due to the construction of the site.

Adopted this _____ day of _____, 2024.

Lee Wong, Chair Yes/No

Mark Welch, Vice Chair Yes/No

ATTEST:

Ann Becker Yes/No

Bruce Jones, Fiscal Officer

APPROVED AS TO FORM:

Scott D. Phillips, Law Director

PROPOSED



WCT Board of Trustees Staff Report

October 8, 2024

CASE No. MC 05-24

NORTH POINTE – STREETS NORTH – THE GATEWAY OF WEST CHESTER; SITE D

CASE HISTORY:

The West Chester Township Board of Trustees approved a Zoning Map Amendment from CBD (Central Business District) to SP-PUD (Special Purpose Planned Unit Development District) and a Preliminary Development Plan (15-2021) on September 22, 2021 for approximately 497,000 square feet of commercial use, 870 multi-family units, and a 140 room hotel (Sites A-O) on approximately 98.6 acres.

The West Chester Township Zoning Commission recommended denial for a Final Development Plan on preliminary Site D for a 6,369 square foot retail/ fueling station and a 3,500 square foot carwash on 4.13 acres on November 21, 2022 (22-13) and April 17, 2023 (23-4). Both of which were withdrawn prior to a hearing with Board of Trustees.

The West Chester Township Zoning Commission recommended denial for a Major Change and Preliminary Development Plan for the previously approved Site D (24-11) on June 17, 2024 for a 4,650 square foot fueling station and convenience store on 2.42 acres and a 2,300 square foot drive-thru restaurant with outdoor seating on 1.71 acres.

REQUEST: Major Change to a PUD

PROPERTY OWNER: Brooks Creek Development, LLC.

APPLICANT: Jamie Pollock, United Properties Development, LLC.

LOCATION:

The site is located along Imagination Boulevard and Union Centre Boulevard. (Parcel M5620027000112 - Section 33, Town 3, Range 2)

SITE DESCRIPTION:

The site consists of a newly platted parcel totaling 4.13 acres on planned Site D. The site is characterized as generally flat and vacant open space, which slightly slopes down to the east property line.

SITE VICINITY:

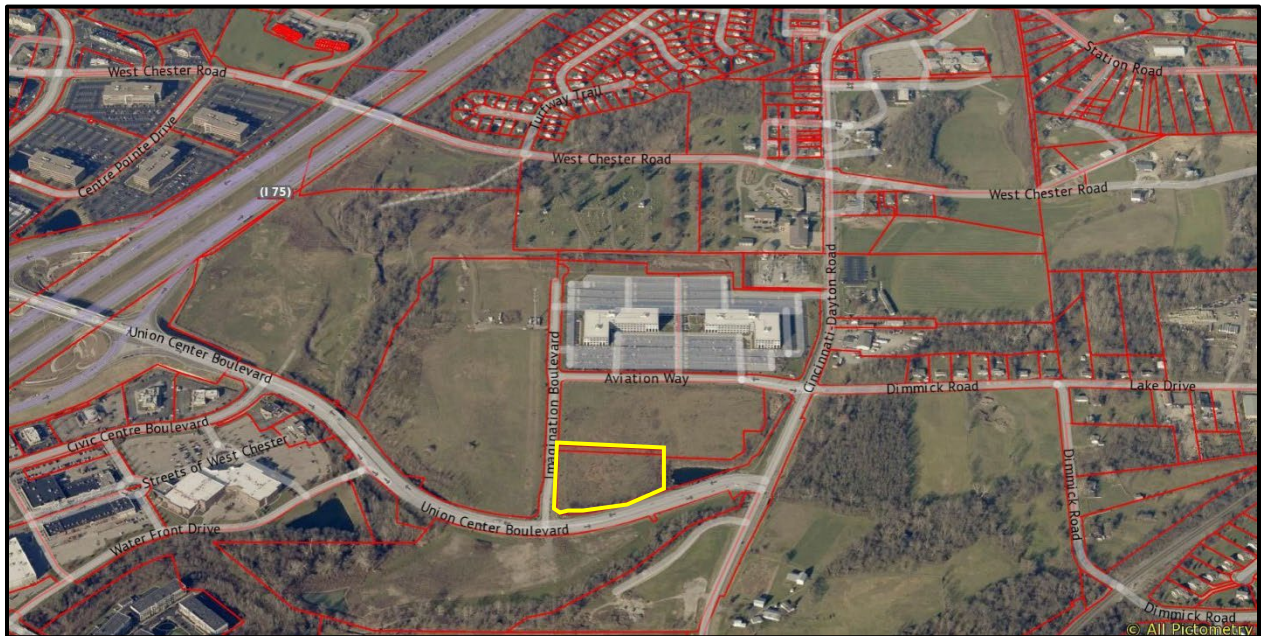

APPLICANT'S PROPOSAL:

The applicant is proposing a re-plat, which would split the existing lot into two parcels for two proposed commercial uses.

Fueling Station/ Convenience Store	4,824 sf
Fueling Station Parking/ Staging	
39 parking spaces provided	33 parking spaces required
Multi-tenant retail w/ outdoor seating	3,600 sf/ 14 outdoor seats
Drive-thru Parking & Stacking	
21 parking spaces provided	12 parking spaces required
Open Space	
38% & 75% open space provided	20% open space required

**STAFF
CONSIDERATIONS:**

The previously approved Preliminary Development Plan (15-2021) established the permitted uses, site layout, density and intensity, access and circulation patterns, design standards, and all common elements and features. The proposed Major Change has been revised from previous submissions in order to be more consistent and meet the original intent of the preliminary approval in regard character, design standards and intensity of uses.

The use of a fuel station was permitted on the subject site. However, in order to obtain approval, the site layout was illustrated on a smaller scale and the fuel station's accessory use was described as a neighborhood retail use that would most likely just include an ice cream parlour and some outdoor seating. The applicant has followed staff's advisement on the orientation of the fuel station in order to maintain the original character and foresight given to the streetscape design standards. Therefore, the only remaining major consideration is the scope of the site.

Giving full consideration to the overall PUD district and adopted design standards, the previous approval permitted three (3) retail/ drive-thru restaurant sites on the previously approved Sites H, I and J at a total of 11,500 square feet. Based on the approved design standards within Article Two, Section 1, the applicant

has the ability to “realign uses from one location... to another...” Therefore, an approval of the subject site, previously approved Site D (fuel station), with the addition of a 3,600 square foot, multi-tenant retail building use would subtract from the previous Sites H, I and J total of area.

Finally, in consideration of the scope of the subject site in comparison to the previous preliminary plans. The Board did not have the opportunity to hear from the property owner and his reasons for how and why the site was altered in relation to the previously approved site F, to the north, which was under separate ownership. Therefore, consideration should be given to the property owners testimony at the hearing.

In regard to minor considerations, the application narrative and site plan data table will need to be revised to match current proposal and submitted to the WCTCDD staff within 30 days of an approval. Additionally, streetscape elements, such as benches, trash cans, etc., as recommended in the site design standards Article Four, Section 2, B (b) will need to be submitted at the Final Development Plan (FDP) stage.

The Butler County Engineer’s Office (BCEO) has indicated all detailed site civil plans will need to be coordinated at the FDP stage, to specifically include the following at this time:

- a.) Vehicular access to both lots will only be permitted from Imagination Way;
- b.) A truck-turning template will need to be used to ensure maneuverability of larger trucks;
- c.) A sight distance study will be required along the cross-access way and Imagination Way;
- d.) Consideration should be given for a direct outlet of the drive-thru to the proposed cross-access way; and
- e.) Clarification is required for any proposed work in the right-of-way.

The Butler County Water and Sewer Department (BCWSD) has indicated all detailed site civil plans will need to be coordinated at the FDP stage, to specifically include the following:

- a.) Each lot shall be accessible to public water and sewer connections; and
- b.) A food plan approval will need to be acquired before plumbing permits are granted.

The West Chester Fire Department has indicated the applicant will need to coordinate and meet all applicable fire code requirements at the subsequent stages, to specifically include the following:

- a.) All permits, testing and inspection of underground fuel tanks shall go through the State Fire Marshall's Bureau (BUSTR);
- b.) Applicant shall confirm 24 hour operations and attendance of fuel station pumps, to determine if canopy fire suppression system is needed;
- c.) "No Parking" fire lanes shall be coordinated with the FD;
- d.) Underground fire main will be required to be looped through the site; and
- e.) All drive aisles will need to meet safety service vehicle turning radius requirements.

The West Chester Community Services Department has indicated that any relocation of street lights (and associated cost) to accommodate the development will be the responsibility of the developer/contractor.

The Butler County Health District has indicated any food facilities will need to submit food plans for review before building permits will be issued.

Contrary to requesting any variances for an increase in the typical requirements for accessory structures or signage, the applicant has agreed with staff that one (1) monument sign at a maximum of eight (8) foot in height and forty-eight (48) square feet of display area would be sufficient for each site. However, further consideration should be given to prohibit any internally-illuminated building/canopy signs to be directed to the north into the residential district.

A landscaping plan has been provided this time, which provides an adequate streetscape design and a buffer between the sounds and odors of the uses and anyone utilizing the hiker/biker path located along the both frontages.

The Butler County Planning Commission held a public hearing on August 13th and recommended approval. The Township Zoning Commission held a public hearing on August 19th and given all considerations in regard to the existing conditions; the proposed use in relation to the surrounding character; and the overall general welfare of the County and Township, the Zoning Commission recommended approval of the zoning map amendment.

All other requirements in regard to detailed engineering, building elevations and floor plans, interior amenities, lighting, trash collection, signage, landscaping plans, etc. will be addressed further at the FDP stage, unless the applicant cannot provide adequate information or adequately address any of the Board members concerns at the public hearing.

ACTION: The Board of Trustees may now approve, approve with modifications, or deny the submitted Major Change, unless additional information is deemed necessary to make an informed decision.

APPLICATION FOR A MAJOR CHANGE
TO A PUD DISTRICT
WEST CHESTER TOWNSHIP COMMUNITY DEVELOPMENT DEPARTMENT
9577 Beckett Road, Suite 100, West Chester, Ohio 45069
Telephone: (513) 777-4214

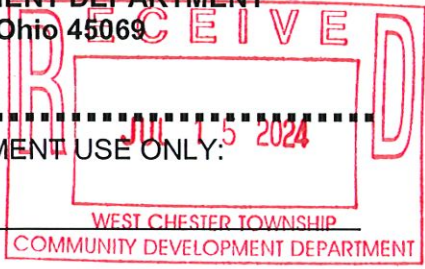

FOR WEST CHESTER COMMUNITY DEVELOPMENT DEPARTMENT USE ONLY:

CASE # MC 05-24
The Gateway of WC's Sites
FEE RECEIPT # _____

DATE RECEIVED: _____
RECEIVED BY: BKW

THIS APPLICATION MUST BE TYPEWRITTEN - USE ADDITIONAL SHEETS IF NECESSARY

NAME OF APPLICANT Jamie Pollock - United Properties Development, LLC

ADDRESS 1331 17th St, Suite 604

CITY/STATE/ZIP Denver, CO 80202

PHONE NO. 763-360-7854 FAX NO. _____

EMAIL jamie.pollock@uproperties.com

NAME, ADDRESS & PARCEL NUMBER OF EACH PROPERTY OWNER OF RECORD
WITHIN THE PROPERTY WHICH IS REQUESTED FOR THE MAJOR CHANGE:

- M5620-02.000-112 - Imagination Boulevard West Chester, OH 45069. Brooks Creek Development LLC
- _____
- _____

REQUEST RE-DESIGNATION OF AREA FROM _____ TO _____

TOTAL ACRES 4.131

LOCATION OF PROPERTY FOR MAJOR CHANGE:

SECTION 27 TOWN 3 RANGE 2
PARCEL (S) _____

PROPERTY ADDRESS _____

CITY/STATE/ZIP West Chester, OH 45069

(MY) (OUR) INTEREST IN THE PROPERTY TO BE RECLASSIFIED IS AS:

OWNER _____ AGENT LESSEE _____ OPTIONEE _____

APPLICANT Jamie Pollock 1331 17th St, Suite 604 Denver, CO 80202 303-667-3358
Signature Address/City/ST/Zip Phone Number

OWNER (S) Brooks Creek Development, LLC
B. Smith 8160 Corp Park Dr. Cincinnati, OH 45242 (513) 678-2138
Signature Address/City/ST/Zip Phone Number

DESCRIPTION OF REQUEST AND REASONS FOR MAJOR CHANGE TO PUD DISTRICT
WEST CHESTER TOWNSHIP COMMUNITY DEVELOPMENT DEPARTMENT
9577 Beckett Road, Suite 100, West Chester, Ohio 45069
Telephone: (513) 777-4214

FOR WEST CHESTER COMMUNITY DEVELOPMENT DEPARTMENT USE ONLY:

CASE # MC 05-24
The Gateway of KC; Site D

DATE RECEIVED:

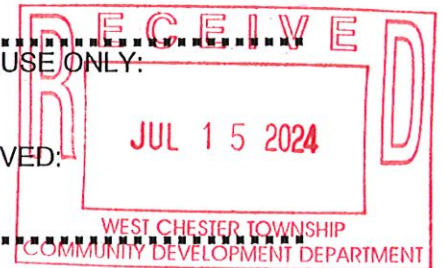

NOTE: THIS APPLICATION SHOULD BE TYPEWRITTEN

The area of land sought to be changed contains approximately 4.131 acres, having frontage of approximately 520 feet located (1) along the north side of Union Centre Boulevard approximately 410 feet east of Imagination Or (2) at the _____ corner of the intersection of _____ and Boulevard.

THE APPLICANT SHOULD PREPARE DEFINITIVE STATEMENTS REGARDING THE FOLLOWING: (USE ADDITIONAL SHEETS IF NECESSARY)

- 1) What are the specific changes in the character and conditions of the area, which have occurred to make the property no longer suitable or appropriate for the existing PUD classification or to make the property appropriate for the proposed PUD district?
The SP-PUD that was approved in August 2021 proposed a 5,000 SF fuel station on the corner of Imagination Boulevard and Union Centre Boulevard. The applicant is now proposing a 4,650 SF fuel station on the western portion of the site, along with a drive through 2,365 SF cafe / coffee shop on the eastern portion of the site. The addition of the coffee shop was driven by the size of the site and priority to have a use that would be valued by the residents living in neighborhood.
- 2) What is the benefit that the neighborhood or community as a whole will derive from this change?
The main change that the applicant is proposing is the addition of a cafe / coffee shop to the east of the proposed gas station that was previously stipulated in the approved SP-PUD. Our goal was to create a use that would be viewed as an amenity by residents living in North Pointe. We believe a coffee user would be a valued addition to the neighborhood and a use that residents can walk to and enjoy year round. The inclusion of outdoor seating in both proposed uses will also serve as gathering spaces for the community.
- 3) Will the site be accessible from public roads, which are adequate to carry the traffic that will be imposed upon them if the change is granted, or will road improvements be required?
The property is accessible from two main public roadways: Union Centre Boulevard and Imagination Boulevard. The site plan calls for an addition of a private road that would provide access to the proposed cafe / coffee shop on the eastern portion of the site. The applicant will work with the Butler County Engineers Office (BCEO) to ensure roadway access and design are acceptable and approved by BCEO.
- 4) Has this change been discussed with regard to traffic design with the Butler County Engineer's office? When? Who? Yes, the applicant had a call with BCEO on 5/17/24. Eric Pottenger, Matthew Loeffler, and Christopher Palmer were all present for that meeting and they did not note any issues with the proposed site plan or access points.
- 5) Is the property currently or can it be serviced by public sewer and water and can proper drainage be provided?
Yes - there is an existing 8" sanitary sewer line along the west side of Imagination Boulevard and an existing water line along the east side of Imagination Boulevard that can serve the property.

6) What is the anticipated proposed use of the property and character (architectural treatment) of the development?

There are two proposed uses for the property - 1) Gas Station & 2) Coffee Shop / Cafe (Starbucks). It was a priority to maintain the connectivity to the sidewalks that run along Union Centre Boulevard and Imagination Boulevard that connect to the trail system along the East Fork of the Mill Creek. Another important component is the focus on the landscaped frontage and outdoor seating component for residents in the community which are shown on both proposed uses. It will also be important to design the facades of the building to achieve the look of a cohesive urban village. As mentioned in the design standards, we will look to use differing building materials such as brick, pre-cast masonry, stucco, and wood to maintain a unified development within North Pointe.

PROPERTY OWNER'S AFFIDAVIT

STATE OF OHIO
COUNTY OF BUTLER

I (we) Peter Mather, Manager Brooks Creek Dev.
hereby certify that we are all of the owners of the real estate which is the subject of the pending zoning application; that we hereby consent to the Board of Trustees of West Chester Township approving a Major Change to a PUD for the subject real estate; that we understand that our application will be considered and processed in accordance with the regulations as set forth by the West Chester Township Community Development Department and Zoning Resolution; that we agree to accept, fulfill and abide by those regulations and all stipulations and conditions attached to the Major Change to the PUD plan. I (we) authorize West Chester Township to place a Public Meeting notification sign on the property. I (we) authorize West Chester Township staff and board members to enter and inspect the property. The statements and attached exhibits are in all respects true and correct to the best of my/our knowledge and belief.

Peter Mather
Signature

Peter Mather
Printed Name

8160 Corporates Park Dr.
Mailing Address

Cincinnati, OH 45242
City / State / Zip

513-678-2138
Phone

Subscribed and sworn to before me this 15 day of July 2024

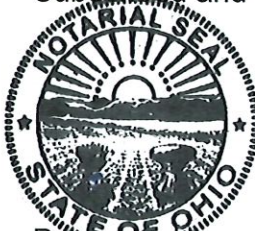

GOLDIE SHARP
Notary Public, State of Ohio
My Commission Expires 08-15-2024

Goldie Sharp
Notary Public

Persons to be contacted for details, other than signatory:

Name	Address/City/St/Zip	Phone Number
------	---------------------	--------------

Z:\project\Butler\WestChester\wp\BUT-WCH-2404\SIRGasStationSite\BUTWCH2404_Concept7.dwg 12-Jul-24 7:12 AM

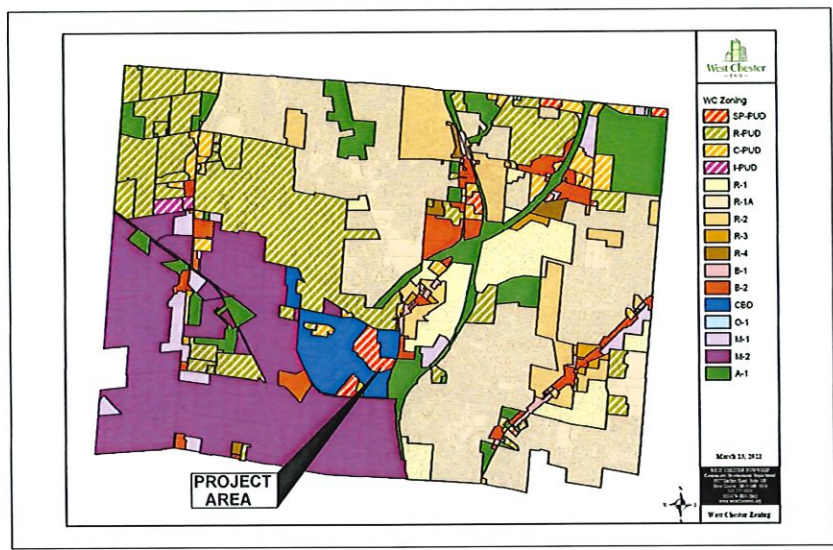
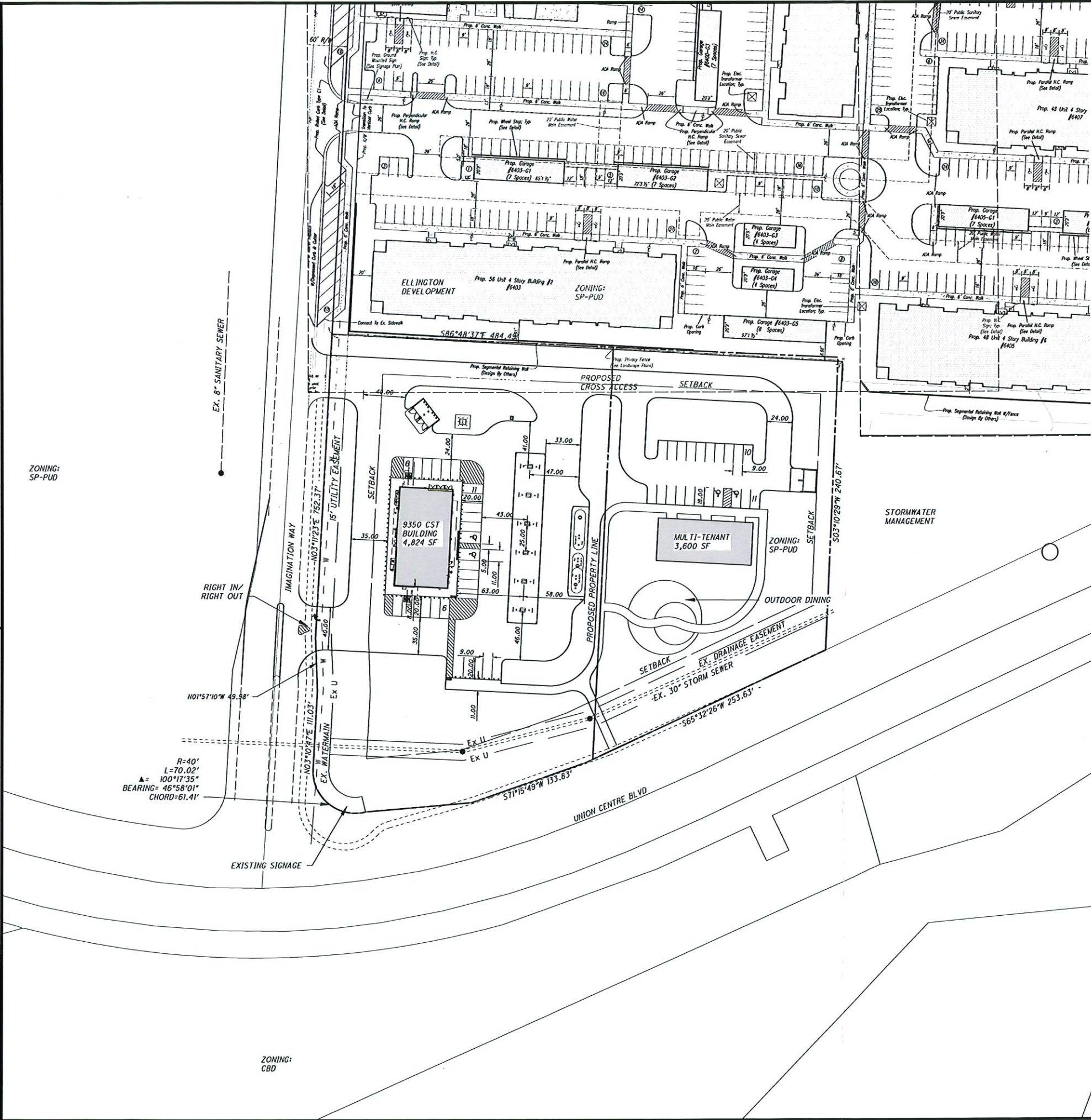

ZONING MAP

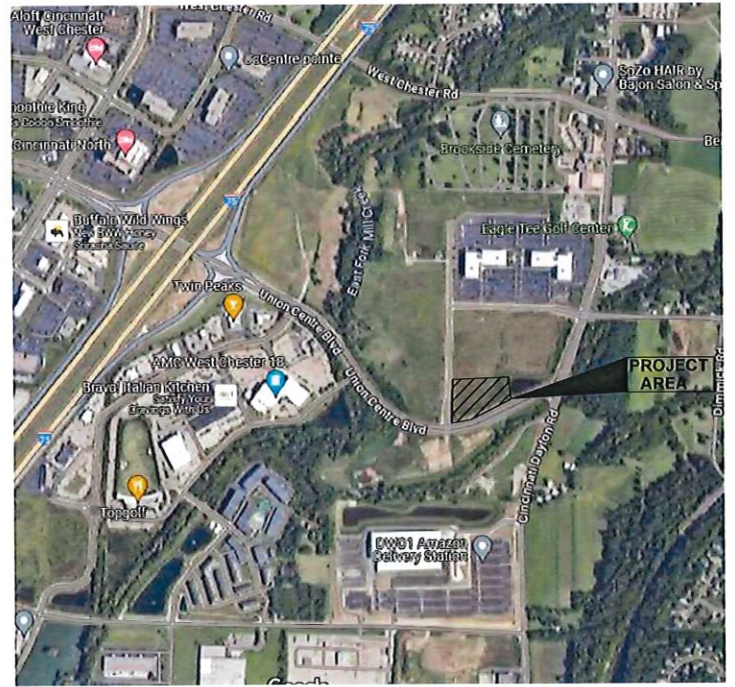

VICINITY MAP

APPLICANT:
 UNITED PROPERTIES
 303 COLORADO STREET SUITE 1500
 AUSTIN, TX 78701

OWNER:
 BROOKS CREEK DEVELOPMENT LLC
 8160 CORPORATE PARK DR STE 300
 CINCINNATI, OH 45242

SUMMARY TABLE:

TOTAL SITE AREA: 4.131 Ac.

PROPOSED USE: GAS STATION
 PARKING SPACES: 39
 PARKING SPACES REQUIRED: 31
 FLOOR AREA: 4,650 SF

PROPOSED USE: RESTAURANT AND DRIVE THROUGH
 PARKING SPACES: 20
 PARKING SPACES REQUIRED: 15
 FLOOR AREA: 2,300 SF
 INDOOR SEATING: 25
 OUTDOOR SEATING: 14

DEVELOPMENT DATA:
 PARCEL NUMBER:
 M5620027000112

CURRENT ZONING: SP-PUD
 CURRENT USE: VACANT

*CONTOURS BASED ON COUNTY GIS

SCHEDULE TO BE DETERMINED UPON ZONING APPROVAL.

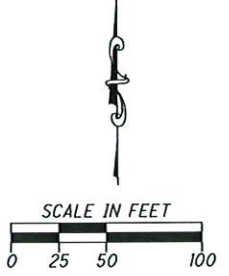

REVISIONS:

FILE NAME	POP
DRAWN BY	JLH
CHECKED BY	RJL
PROJECT No.	BUTWCH2404
DATE	07-08-2024
SHEET NUMBER	1 OF 3

Z:\project\Butler\WestChester\tp\BUT-WCH-2404SIRGasStationSite\BUTWCH2404_Concept7.dwg 12-Jul-24 7:12 AM

SIR WEST CHESTER GAS STATION AND STARBUCKS
CITY OF WEST CHESTER
PRELIMINARY DEVELOPMENT PLAN - TRAFFIC

REVISIONS:

FILE NAME	POP TURN
DRAWN BY	JLH
CHECKED BY	RJL
PROJECT No.	BUTWCH2404
DATE	07-08-2024
SHEET NUMBER	2 OF 3

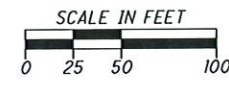
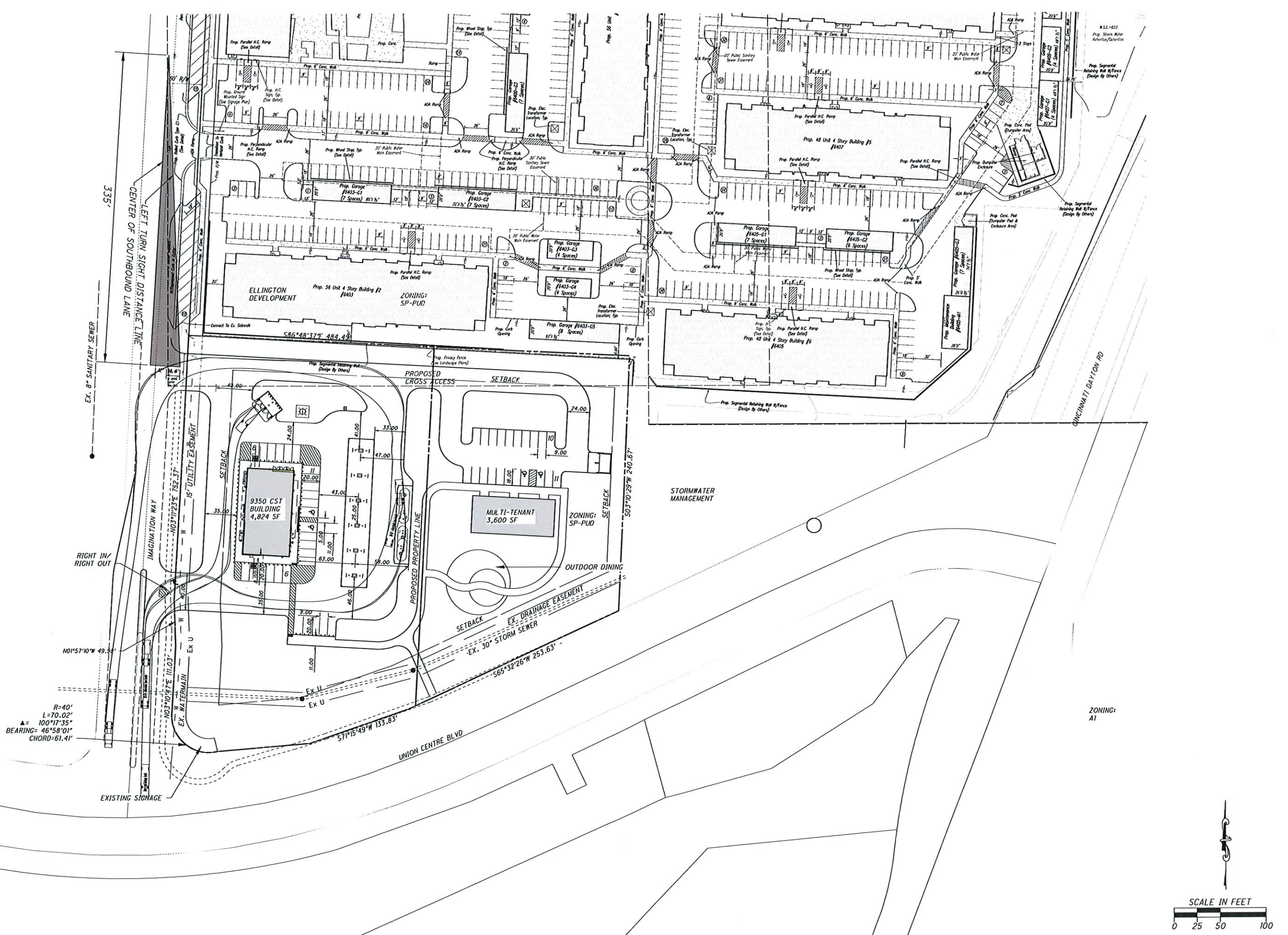

ZONING: SP-PUD

ZONING: SP-PUD

ZONING: A1

Z:\project\Butler\WestChester\BUT-WCH-2404\SIRGasStationSite\BUTWCH2404_Concept7.dwg 12-Jul-24 7:12 AM

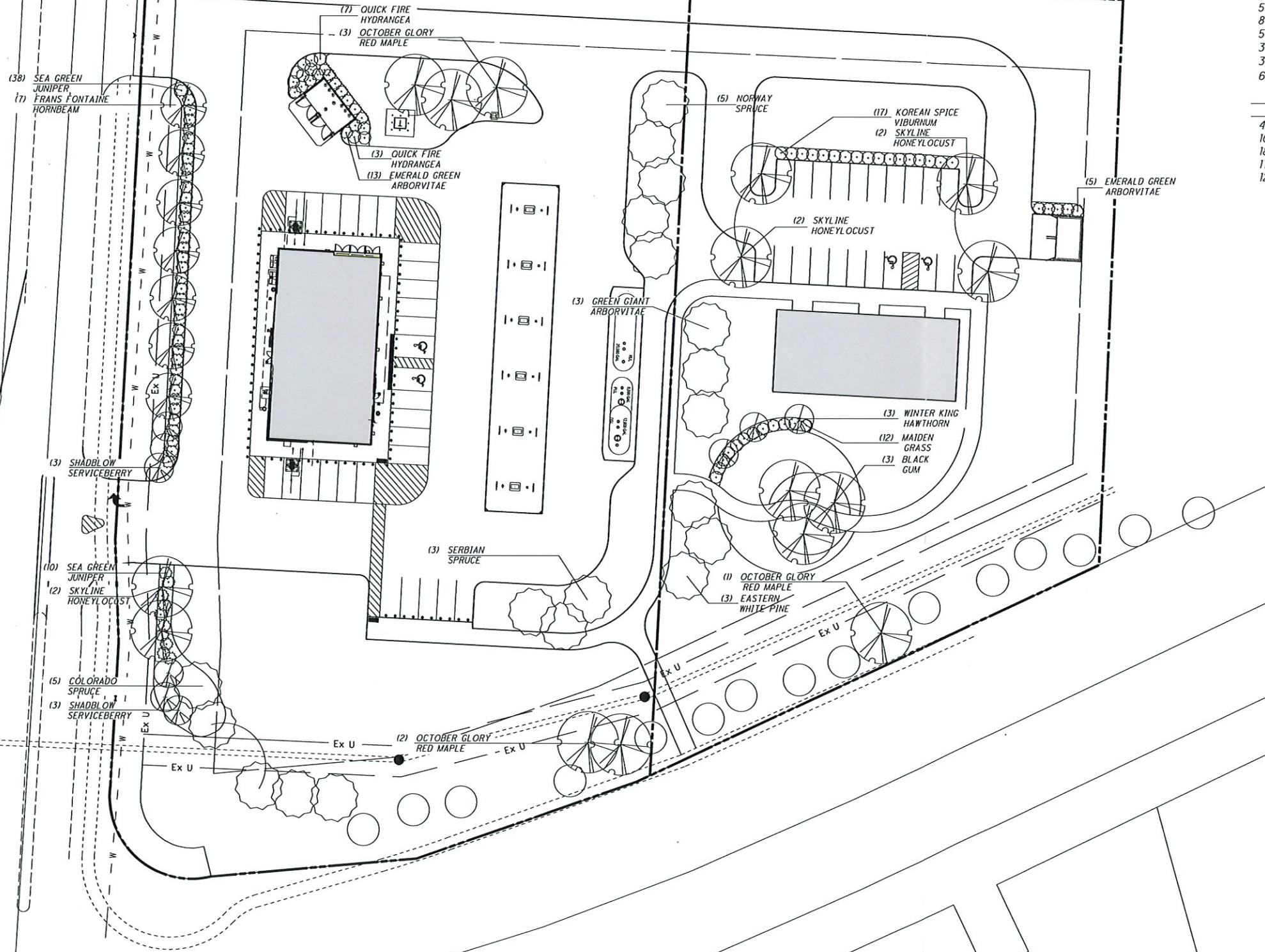

PLANTING SCHEDULE

QTY.	COMMON NAME	BOTANICAL NAME	SIZE	ROOT
TREES				
7	FRANS FONTAINE HORNBEAM	CARPINUS BETULUS 'FRANS FONTAINE'	2" CAL.	B&B
6	SHADBLow SERVICEBERRY	AMELANCHIER CANADENSIS	1.5" CAL.	B&B
6	SKYLINE HONEYLOCUST	GLEDITSIA T. I. 'SKYLINE'	2" CAL.	B&B
3	WINTER KING HAWTHORN	CRATAEGUS V. 'WINTER KING'	2" CAL.	B&B
3	BLACK GUM	NYSSA SYLVATICA	2" CAL.	B&B
5	COLORADO SPRUCE	PICEA PUNGENS	7' HGT.	B&B
8	GREEN GIANT ARBORVITAE	THUJA P. 'GREEN GIANT'	7' HGT.	B&B
5	NORWAY SPRUCE	PICEA ABIES	7' HGT.	B&B
3	EASTERN WHITE PINE	PINUS STROBUS	7' HGT.	B&B
3	SERBIAN SPRUCE	PICEA OMORIKA	7' HGT.	B&B
6	OCTOBER GLORY RED MAPLE	ACER R. 'OCTOBER GLORY'	2" CAL.	B&B
SHRUBS				
48	SEA GREEN JUNIPER	JUNIPERUS CH. 'SEA GREEN'	24" SPR.	B&B
10	QUICK FIRE HYDRANGEA	HYDRANGEA P. 'QUICK FIRE'	18" SPR.	NO. 3 CONT.
18	EMERALD GREEN ARBORVITAE	THUJA O. 'SMARAGD'	6' HGT.	B&B
17	KOREAN SPICE VIBURNUM	VIBURNUM CARLESII	24" SPR.	NO. 5 CONT.
12	MAIDEN GRASS	MISCANTHUS SINENSIS	CLUMP	NO. 2 CONT.

LANDSCAPING REQUIREMENTS

FRONTAGE LANDSCAPING:
TREES: 1.5 PER 40' OF FRONTAGE

IMAGINATION BLVD: 448
REQUIRED: 448 / 40 * 1.5 = 17 TREES
PROVIDED: 17 TREES

UNION CENTRE BLVD: 500 LF
REQUIRED: 500 / 40 * 1.5 = 19 TREES
EXISTING: 13 TREES
PROVIDED: 6 TREES

INTERIOR LANDSCAPE:
20 SF FOR EVERY 1,000 SF OF IMPERVIOUS SURFACE
REQUIRED: 84,000 * 0.02 = 1,680 SF
PROVIDED: 3,834 SF

PARKING LANDSCAPE:
5 SF FOR EVERY 100 SF OF PARKING AREA
REQUIRED: 10,244 / 0.05 = 512 SF
PROVIDED: 1,102 SF
1 TREE PER 5,000 SF OF IMPERVIOUS SURFACE
REQUIRED: 10,244 / 5,000 = 3 TREES
PROVIDED: 4 TREES

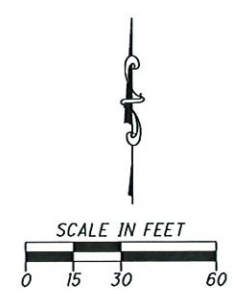

REVISIONS:

FILE NAME	POP-LANDSCAPE
DRAWN BY	JLH
CHECKED BY	RJL
PROJECT No.	BUTWCH2404
DATE	07-08-2024
SHEET NUMBER	3 OF 3

AGENDA ITEM COVER SHEET



Trustee Meeting Date:	Agenda Item Type:
October 8, 2024	Resolution Item
Submitted By:	
Katy Kanelopoulos, Director of Community Development	

Motion:
Resolution 39-2024 approving Major Change for Case #ZMA 06-24 EnterTRAINment Junction; Place of Worship Redevelopment

Background:
The applicant is requesting a Zoning Map Amendment from SP-PUD (Special Purpose Planned Unit Development) to C-PUD (Commercial Planned Unit Development) for commercial alteration to an 80,000 s.f. building for a place of worship on six acres located at 7379 Squire Court. Parcel #: M5620-172-000-017

Finance	Budgeted Item:	N/A;		
	CIP #:			
	TIF Info:			
	Purchase Order:		Total Encumbrance:	\$.00

RESOLUTION NO. 39-2024

Resolution approving a Zoning Map Amendment from SP-PUD (Special Purpose Planned Unit Development District) to C-PUD (Commercial Planned Unit Development District) and Preliminary Development Plan for Entertainment Junction; Place of Worship Redevelopment, Case #ZMA 06-24

WHEREAS, on June 27, 2006, the West Chester Township Board of Trustees approved a Zoning Map Amendment from M-1 (Light Industrial District) to SP-PUD (Special Purpose Planned Unit Development District) and a Preliminary Development Plan (26-2006) for a redevelopment of the existing building for a railroad-themed museum and entertainment center on approximately 6 acres; and,

WHEREAS, on August 16, 2024, Michael Spillane, on behalf of Tri-State Umiya Dharma, submitted an application requesting a Zoning Map Amendment from SP-PUD (Special Purpose Planned Unit Development District) to C-PUD (Commercial Planned Unit Development District) and Preliminary Development Plan for the redevelopment of the existing 80,000 square foot building for the use of a place of worship and corresponding accessory uses on approximately 6 acres; and,

WHEREAS, on September 10, 2024, the Butler County Planning Commission conducted a public hearing for the aforesaid application and recommended approval; and,

WHEREAS, on September 16, 2024, the West Chester Township Zoning Commission conducted a public hearing for the aforesaid application recommended approval; and,

WHEREAS, by advertisement, a public hearing for the aforesaid application was conducted before the West Chester Township Board of Trustees on October 8, 2024, as applied for by Michael Spillane; and,

WHEREAS, all those present for the hearing who wished to be heard voiced their opinions with respect thereto; and,

NOW THEREFORE, BE IT RESOLVED that on the basis of the above actions and findings, the West Chester Township Board of Trustees hereby approve the Zoning Map Amendment from SP-PUD (Special Purpose Planned Unit Development District) to C-PUD (Commercial Planned Unit Development District) and Preliminary Development Plan with the following conditions:

SECTION 1. The permitted uses shall only include the principle use of a place of worship and those accessory uses as approved on the Preliminary Development Plan (PDP), which include the following:

- a.) A principle worship facility, including auditorium/ temple, kitchen, dining, office and recreational activity areas; excluding public/private elementary schools, high schools, and universities; and
- b.) An accessory office facility for church staff and related accessory uses;

SECTION 2. Any outdoor recreational area shall be subject to the West Chester Township Zoning Resolution (WCTZR), Article 22.0212.

SECTION 3. Outdoor audio speakers shall be prohibited.

SECTION 4. All recommendations of the preliminary traffic study and requirements of the Butler County Engineer's Office (BCEO) and West Chester Township (WCT) shall be incorporated into the FDP.

SECTION 5. It shall be the responsibility of the property owner to coordinate with West Chester Township Community Development Department (WCTCDD) and the West Chester Township Police Department in order to make the appropriate accommodations for high traffic volume times and during major events, to include the following:

- a.) Provide additional personnel and resources to facilitate movement of on-site traffic movement and parking; and
- b.) Provide off-duty law enforcement to facilitate traffic movement and access to the site from the Kingsgate Way and Squire Court public right-of-ways during major events; and
- c.) Provide for off-duty law enforcement to facilitate traffic movement and access to the site from the Kingsgate Way and Squire Court public right-of-ways, at which time deemed necessary by WCT agencies; and
- d.) All parking in connection with the site shall be contained within the site.

SECTION 6. All All access ways and internal roadways; connections and locations of fire hydrants; fire lane signage; and all other applicable building and fire codes shall be coordinated with the WCTCDD and the WCTFD and shall be incorporated into the FDP phase to ensure the site accommodates emergency services. Fire hydrants shall not be physically or visually obstructed.

SECTION 7. Detailed grading plans, stormwater drainage plans and calculations, and water and sanitary utility plans addressing all preliminary review requirements shall be provided at the FDP stage and shall meet all requirements of WCT and all other applicable reviewing agencies.

SECTION 8. Detailed floor plans and building elevations shall be provided at the FDP stage.

SECTION 9. Dumpster and donation enclosure locations and details shall be provided at each FDP stage. The enclosures shall comply with the provisions of the West Chester Township Zoning Resolution (WCTZR), Articles 10.031 and 20.043 and shall be consistent with the high-quality building materials of the principle building. Dumpster enclosures shall be located in a manner to reduce detrimental impacts to the adjacent residential subdivision.

SECTION 10. A detailed landscaping plan shall be provided at the FDP stage, which shall illustrate adequate screening elements along the south property line, determined by the WCTCDD staff to be necessary, to include an adequate tree plantings along the frontage of the site.

SECTION 11. The property owner or a recorded property owners' association shall be responsible for keeping all common features and elements well maintained and free from trash and litter; maintaining all drainage ways to ensure the detention areas perform the designated function; and all landscaping shall be well maintained in good condition and all major landscaping shall be irrigated with a permanent system prior to the issuance of a zoning certificate.

SECTION 12. All signs shall be pursuant to the WCTZR Article 17, excluding ground sign locations and internally-illuminated building signs. Internally-illuminated building signs shall be prohibited on the south building wall elevation. All sign structures shall be consistent with the exterior building materials of the principle building.

Adopted this _____ day of _____, 2024.

ATTEST:

Bruce Jones, Fiscal Officer

APPROVED AS TO FORM:

Scott D. Phillips, Law Director

_____ Lee Wong, Chair	_____ Yes/No
_____ Mark Welch, Vice Chair	_____ Yes/No
_____ Ann Becker	_____ Yes/No



WCT Board of Trustees Staff Report

October 8, 2024

CASE NO. ZMA 06-24

ENTERTRAINMENT JUNCTION; PLACE OF WORSHIP REDEVELOPMENT

CASE HISTORY:

The West Chester Township Board of Trustees approved a Zoning Map Amendment from M-1 (Light Industrial District) to SP-PUD (Special Purpose Planned Unit Development District) and a Preliminary Development Plan (26-2006) on June 27, 2006 for a redevelopment of the existing building for a railroad-themed museum and entertainment center on approximately 6 acres.

The West Chester Township Zoning Commission approved a Final Development Plan (06-40) on October 16, 2006 for a for a railroad-themed museum and entertainment center on approximately 6 acres.

A Revised Final Development Plan (10-02) was approved for an outdoor train ride on the south and west sides of the building.

REQUEST: Zoning Map Amendment - District Reclassification

FROM: SP-PUD (Special Purpose Planned Unit Development District)
TO: C- PUD (Commercial Planned Unit Development District)

PROPERTY OWNER: Squire Road Property, LLC.

APPLICANT: Michael Spillane, on behalf of Tri-State Umiya Dharma

LOCATION:

The site is located along Squire Court. (Parcel M5620172000017- Section 17, Town 3, Range 2)

SITE DESCRIPTION:

The site consists of 6 acres. The site is characterized as flat and consists of an existing 80,000 square foot building and a mature tree line along the south property line.

CURRENT ZONING:



**SURROUNDING
CONDITIONS:**

Existing Zoning

North: M-1 Light Industrial District

East: M-1 Light Industrial District

South: R-4 Multiple Family District

West: I-75

Proposed Land Use Map:

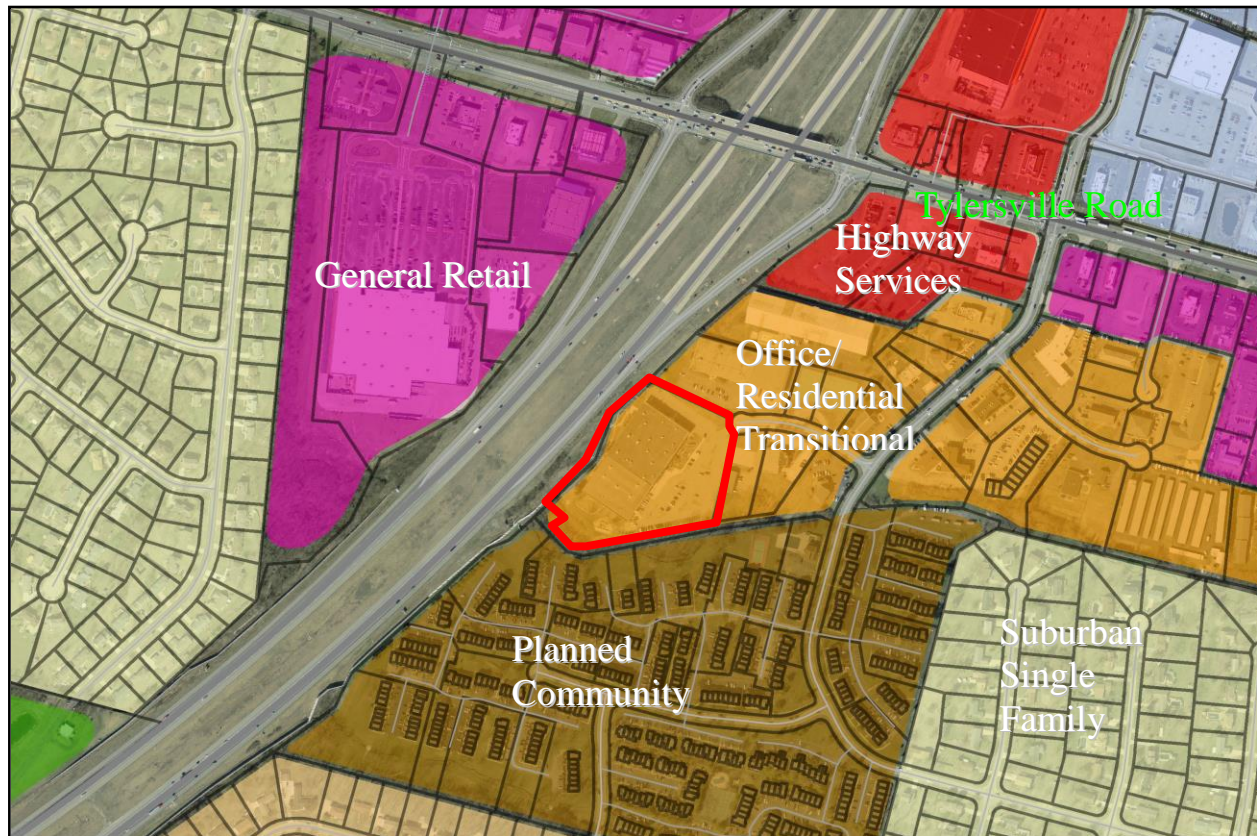

The West Chester Township Comprehensive Land Use Plan (CLUP) proposes Office/ Residential Transitional as the adopted land use recommendation for the subject site.

- **Office/ Residential Transitional** – “Medium density detached or attached housing, low-intensity office uses and related compatible uses that provide a transition between single-family residential uses and other types of development.

General Location and Development Characteristics:

- Excludes industrial uses and retail, except low-intensity retail that adds a neighborhood amenity;
- Densities consistent with surrounding uses, but not exceeding five dwelling units per acre;

- Residential characteristics - Limited to single story standalone or duplexes with pitched roofs and attached garages, or neo traditional design;
- Near major road corridor;
- Professional office uses;
- Landscaped buffers and berms;
- Parking in rear of buildings – screened from adjacent residential uses; and
- Access points consolidated with adjacent developments to minimize curb-cuts along main corridors.

APPLICANT'S PROPOSAL:

Total Area	80,000 sf
<i>Aditorium</i>	27,000 sf / 400 seats
<i>Accessory activity space</i>	53,000 sf
Total Parking	
167 parking spaces provided	134 parking spaces required
<i>Worship use</i>	
50 parking spaces provided	50 parking spaces required (1/ 8 seats)
<i>Office use</i>	
117 parking spaces provided	132 parking spaces required (1/ 400 sf)
Open Space	
27% open space provided	20% open space required

STAFF CONSIDERATIONS:

The subject site is consistent with the intent and purpose of the West Chester Township Comprehensive Land Use Plan's (CLUP) recommended Office/ Residential Transitional land use classification by achieving compatibility with the surrounding land uses. The site is located along Squire Court in close proximity to the I-75 interchange, Kingsgate Way and Tylersville Road. While the commercial alteration to the existing museum/ neighborhood retail use will not include a residential character, the use for place of worship should be considered a compatible use that would provide a transition from the higher intensity commercial uses along Tylersville Road and the Residential district to the south.

The principle use, the proposed place of worship, includes an auditorium, kitchen, dining, office, and recreational activity areas. The area labeled “Temple” has been specified and has been calculated into the parking requirements.

The Butler County Engineer’s Office (BCEO) has indicated coordination will need to occur to address all concerns of the traffic study, which will be required to be incorporated into the Final Development Plan.

Butler County has not had any comments to address in regard to Preliminary grading plans, stormwater drainage plans and calculations, and water and sanitary plans at this time.

In consideration of reducing any detrimental impacts to the adjacent residential subdivision, any dumpster or donation enclosures should be located an appropriate distance from the residential subdivision and trash pick-up times should occur at an appropriate time during the day.

Further consideration of reducing any detrimental impacts to the adjacent residential subdivision should include a photometric analysis, which demonstrates that adequate light levels are being maintained and are limited to 0.02 foot candles along the south property line. Also, appropriate light fixtures should be utilized that provide shielding of the light bulb and protect from glare and spillover.

A landscaping plan has not been provided at the preliminary stage. The mature tree-line along the south property line should be maintained to ensure proper buffering and screening of the residential district to the south. Furthermore, additional tree plantings should be provided within along the frontage of the site to enhance the transitional character.

Preliminary sign type and locations were provided, but defined locations and details of the signs were not provided. In order to remain consistent with a transitional area, consideration should be given to only permit signage that would be subject to the WCTZR, Article 17 and any ground sign structures should be consistent with the materials of the principle building.

The Butler County Planning Commission held a public hearing on September 10th and recommended approval. The Township Zoning Commission held a public hearing on September 16th and given all considerations in regard to the existing conditions; the proposed use in relation to the surrounding character; and the overall general welfare of the County and Township, the Zoning Commission recommended approval of the zoning map amendment.

ACTION: The Board of Trustees may now approve, approve with modifications, or deny the submitted Zoning Map Amendment and Preliminary Development Plan, unless additional information is deemed necessary to make an informed decision.



Application for a

ZONING MAP AMENDMENT TO A PUD DISTRICT



WEST CHESTER COMMUNITY DEVELOPMENT DEPARTMENT
9577 BECKETT ROAD • SUITE 100 • WEST CHESTER, OHIO 45069-5014

A. APPLICANT INFORMATION NAME: <u>Michael Spillane</u> PHONE: (513) <u>771 - 2444</u> ADDRESS: <u>123 Boggs Lane</u> CITY/ST/ZIP: <u>Cincinnati, OH 45246</u> EMAIL: <u>mspillane@cmrs-law.com</u> APPLICANT IS THE: <input type="checkbox"/> PROPERTY OWNER <input type="checkbox"/> AGENT <input checked="" type="checkbox"/> OPTIONEE	 CASE # <u>2019 06-24</u> <u>EnterTRAINment Junction</u> <u>Application for Zoning Amendment</u>
B. PROPERTY INFORMATION PROPERTY ADDRESS (IF ANY): <u>7379 Squire Court</u> CITY/ST/ZIP: <u>West Chester, OH 45069</u> SECTION: <u>17</u> TOWN: <u>3</u> RANGE: <u>2</u> PARCEL #: <u>M 562- 017 -200 - 0017</u> CURRENT USE OF PROPERTY (CHECK ALL THAT APPLY): <input checked="" type="checkbox"/> COMMERCIAL <input type="checkbox"/> RESIDENTIAL <input type="checkbox"/> AGRICULTURAL <input checked="" type="checkbox"/> OTHER	
C. PROPERTY ZONING CURRENT ZONING OF PROPERTY: <u>SP-PUD</u> REQUESTED ZONING OF PROPERTY: <input checked="" type="checkbox"/> C-PUD <input type="checkbox"/> R-PUD <input type="checkbox"/> I-PUD <input type="checkbox"/> SP-PUD TOTAL ACRES OF PROPERTY TO BE REZONED: <u>6.00</u>	PAYMENT INFORMATION FEE AMOUNT: <u>\$800.00</u> RECEIPT #: <u>3706</u> RECEIVED BY: <u>JF</u>
D. PROPERTY OWNER INFORMATION (LIST ALL PARCELS AND PROPERTY OWNERS THAT ARE INCLUDED WITH THIS APPLICATION) 1. PARCEL #: <u>M 562 - 017 -200 - 0017</u> NAME: <u>Squire Road Property, LLC</u> PHONE: (513) <u>383 - 8167</u> ADDRESS: <u>7379 Squire Court, West Chester, OH 45069</u> 2. PARCEL #: <u>M - - - -</u> NAME: _____ PHONE: () _____ ADDRESS: _____ 3. PARCEL #: <u>M - - - -</u> NAME: _____ PHONE: () _____ ADDRESS: _____ 4. PARCEL #: <u>M - - - -</u> NAME: _____ PHONE: () _____ ADDRESS: _____	
E. DESCRIPTION OF REQUEST <u>Rezoning of the current special attraction property containing EnterTRAINment Junction to a commercial planned unit development for the operation of a religious facility and their associated activities.</u>	

As the Applicant, I do hereby agree that I am the Property Owner, or I am submitting this application on behalf of the Property Owner with their knowledge and understanding. Furthermore, I hereby certify that the information and statements provided on this application, drawings and specifications are true and correct to the best of my knowledge and belief. I understand that all information submitted with this application will be assumed to be correct and the Applicant shall assume responsibility for any errors and/or inaccuracies resulting in an improper application.

Applicant Signature: [Signature] Date: 8/14/24
Printed Name: Michael S. Spillane



Submission Instructions and Requirements for a
ZONING MAP AMENDMENT TO A PUD DISTRICT



DESCRIPTION OF REQUEST AND REASONS FOR ZONING MAP AMENDMENT FORM

THE APPLICANT SHOULD PREPARE DEFINITIVE STATEMENTS REGARDING THE FOLLOWING:

1. WHAT ARE THE SPECIFIC CHANGES IN THE CHARACTER AND CONDITIONS OF THE AREA WHICH HAVE OCCURRED TO MAKE THE PROPERTY NO LONGER SUITABLE OR APPROPRIATE FOR THE EXISTING ZONING CLASSIFICATION OR TO MAKE THE PROPERTY APPROPRIATE FOR THE PROPOSED ZONE DISTRICT?

Current SP-PUD zoning is specific to the operation of the model train themed attraction known as EnterTRAINment Junction which includes signage, facade, and outdoor display areas; this facility has announced that they will cease operation early 2025. The proposed zoning will allow for ownership of the existing property by a religious tenant.

2. WHAT IS THE BENEFIT THAT THE NEIGHBORHOOD OR COMMUNITY AS A WHOLE WILL DERIVE FROM THIS ZONE CHANGE?

Existing properties to the east and north are currently zoned M-1, properties to the south are zoned R-4 and future land use identifies this area as office/residential transitional area. Rezoning of the area for a religious facility will help to accomplish the residential transitional area.

3. WILL THE SITE BE ACCESSIBLE FROM PUBLIC ROADS WHICH ARE ADEQUATE TO CARRY THE TRAFFIC THAT WILL BE IMPOSED UPON THEM IF THE REZONING IS GRANTED, OR WILL ROAD IMPROVEMENTS BE REQUIRED?

Road improvements are not anticipated at this point in time and preliminary discussions are happening with Butler County Engineers Office. The proposed facility will have specific days and times of operation and is not expected to be as busy as the current EnterTRAINment Junction facility.

4. HAS THIS REZONING BEEN DISCUSSED WITH REGARD TO TRAFFIC DESIGN WITH THE BUTLER COUNTY ENGINEER'S OFFICE? WHEN? WHO?

Discussions have been started with Matt Loeffler of the Butler County Engineers Office and are currently ongoing.

5. IS THE PROPERTY CURRENTLY OR CAN IT BE SERVICED BY PUBLIC SEWER AND WATER AND CAN PROPER DRAINAGE BE PROVIDED?

The property is currently served by public water and sewer and has adequate drainage provisions.

6. WHAT IS THE ANTICIPATED PROPOSED USE PROPERTY AND CHARACTER (ARCHITECTURAL TREATMENT) OF THE DEVELOPMENT?

The proposed use of the property will be for Religious facility with associated activities, the existing building is intended to remain and consists of concrete panels with minor architectural features. Expansion of the roof is anticipated and parapet heights are requested at 50' above finished floor. Entry features are being added to the driveway and exterior attraction areas are being opened up and converted to play activity areas.

Property Owner	Tax Mailing Address	Parcel
FORLON CORP	CORT FURNITURE RENTAL ATTN: REAL ESTATE DEPARTMENT 14850 CONFERENCE CENTER DR #110 CHANTILLY VA 20151	M5620172000009
7373 KINGSGATE WAY OH WCO LLC	7373 KINGSGATE WAY OH WCO LLC WITH STUDIOS INC 401 BROADWAY FL 18 NEW YORK NY 10013	M5620172000010
7373 KINGSGATE WAY OH WCO LLC	7373 KINGSGATE WAY OH WCO LLC WITH STUDIOS INC 401 BROADWAY FL 18 NEW YORK NY 10013	M5620172000011
LAM SQUIRE COURT LLC	LAM SQUIRE COURT LLC 9005 INDIAN RIDGE LN CINCINNATI OH 45243	M5620172000018
LAM SQUIRE COURT LLC	LAM SQUIRE COURT LLC 9005 INDIAN RIDGE LN CINCINNATI OH 45243	M5620172000019
7419 KINGSGATE WAY	7419 KINGSGATE WAY ENTERPRISE LLC 7419 KINGSGATE WAY WEST CHESTER OH 45069 2449	M5620172000020
KINGSGATE CONDO ASSOCIATION		M5620168000261
SAMAD HASAN A & BASHIR MARIAM	HASAN A SAMAD & MARIAM BASHIR 4787 HAMPTON POND LN MASON OH 45040	M5620168000142
ALEXANDER ROUSH	ALEXANDER ROUSH 7513 OLD ENGLISH DR WEST CHESTER OH 45069 2326	M5620168000141
HARINDERJIT S & MANDEEP K DHILLON	HARINDERJIT S & MANDEEP K DHILLON 4622 WYNDTREE DR WEST CHESTER OH 45069 2326	M5620168000140
ANASTASIA SAMORODSKI	ANASTASIA SAMORODSKI 7517 OLD ENGLISH DR WEST CHESTER OH 45069 2326	M5620168000139

Property Owner	Tax Mailing Address	Parcel
NOAH KEATING ADAMS	NOAH KEATING ADAMS 7519 OLD ENGLISH DR UNIT 219 WEST CHESTER OH 45069 2326	M5620168000138
EDWARD CHRISTMAN	EDWARD CHRISTMAN 7512 OLD ENGLISH DR WEST CHESTER OH 45069 2327	M5620168000136
SHA WANG & LEI WEI	SHA WANG & LEI WEI 3840 WINNING STAKES WAY MASON OH 45040	M5620168000135
LINDA C KREINER	LINDA C KREINER 7516 OLD ENGLISH CT UNIT 215 WEST CHESTER OH 45069 2327	M5620168000134
RICHARD D & LORRAINE FITE	RICHARD D & LORRAINE FITE 7518 OLD ENGLISH DR WEST CHESTER OH 45069 2327	M5620168000133
MARIELA E CABADA-FLORES	MARIELA E CABADA-FLORES 7520 OLD ENGLISH DR UNIT 213 WEST CHESTER OH 45069 2327	M5620168000132
BARB & MARVIN R ANDERSON	BARB & MARVIN R ANDERSON 211 BURKE DR MASON OH 45040	M5620168000131
KEVIN BRUCE TRIBBE	KEVIN BRUCE TRIBBE 7105 WILLOWOOD DR WEST CHESTER OH 45069 2347	M5620168000130
JAN E GORDON	JAN E GORDON 7491 DOVER DR WEST CHESTER OH 45069 2347	M5620168000129
GHAITH R YASEEN & DIANA YASIN	GHAITH R YASEEN & DIANA YASIN 7493 DOVER DR #209 WEST CHESTER OH 45069 2347	M5620168000128
DEBRA CARTER	DEBRA CARTER 7495 DOVER DR #208 WEST CHESTER OH 45069 2347	M5620168000127

Property Owner	Tax Mailing Address	Parcel
FRAZIER HOMES LLC	FRAZIER HOMES LLC 4565 E GALBRAITH RD CINCINNATI OH 45236	M5620168000126
PETER G AND JULIE A STEARNS	PETER G AND JULIE A STEARNS 3925 LUKE LN CARROLLTON TX 75007	M5620168000094
LYNNE M THOMAS	LYNNE M THOMAS 7513 BLACKSTONE CT UNIT 162 WEST CHESTER OH 45069 2351	M5620168000095
LDMD LLC	LDMD LLC 10530 HOPEWOODS CT CINCINNATI OH 45249	M5620168000096
PATRICIA BERTEL	PATRICIA BERTEL 7514 BLACKSTONE CT WEST CHESTER OH 45069 2352	M5620168000093
MATTHEW D AND MICHELLE L MIRANDA	MATTHEW D AND MICHELLE L MIRANDA 5893 NATURE TRL LIBERTY TWP OH 45011	M5620168000085
DEENA BERTRAM	DEENA BERTRAM 7503 PARLIAMENT CT WEST CHESTER OH 45069 2324	M5620168000086
DOUGLAS MUJEYE & CHRISTINE MAZHATA	DOUGLAS MUJEYE & CHRISTINE MAZHATA 8006 LOGANS RIDGE DR WEST CHESTER OH 45069 2324	M5620168000087
TD KINGSGATE REALTY LLC	TD KINGSGATE REALTY LLC 5640 GLEN OAK MASON OH 45040	M5620168000088

7379 SQUIRE COURT REZONE

WESTCHESTER TOWNSHIP, BUTLER COUNTY, OHIO

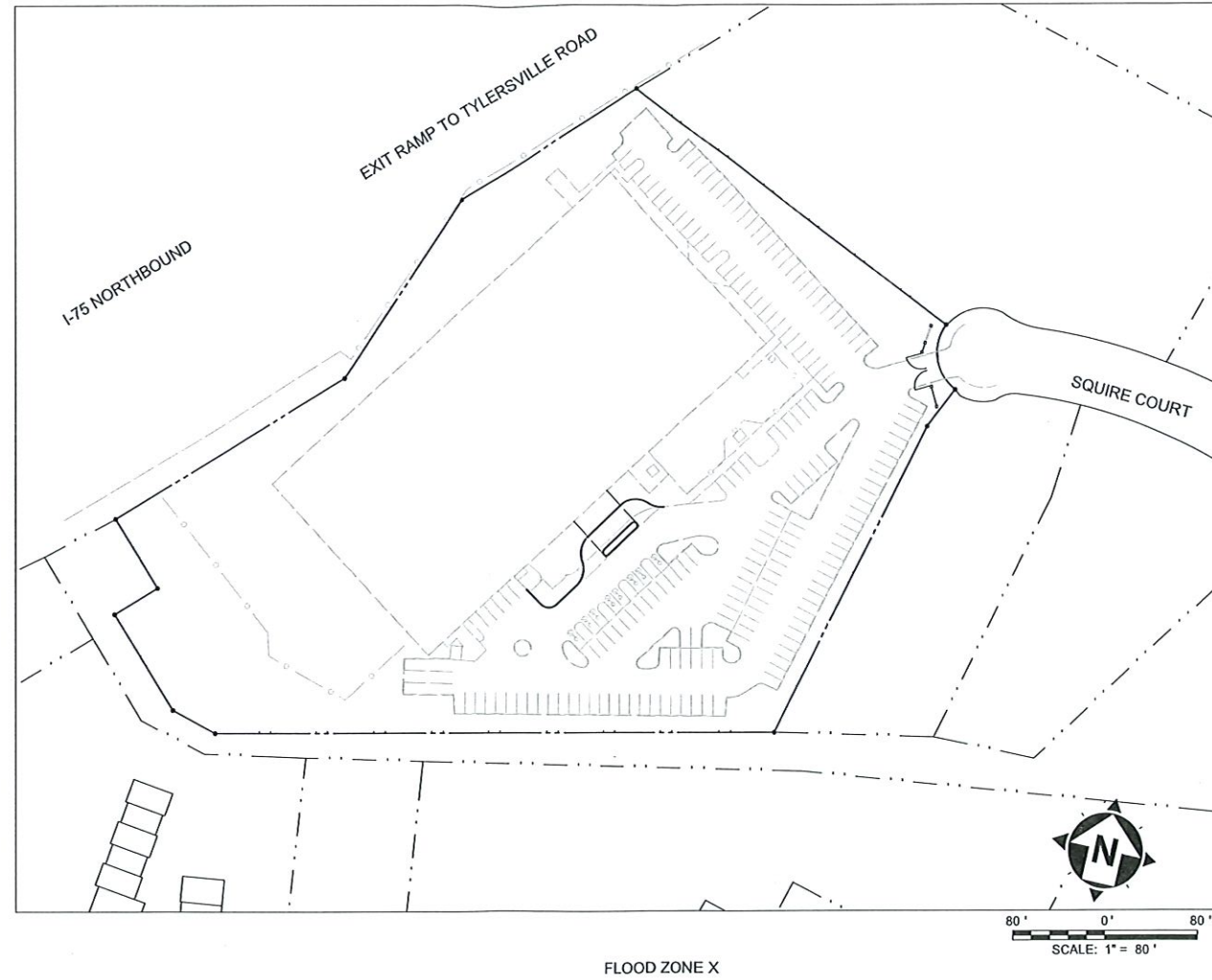

INDEX OF SHEETS	
No.	Title
C01	TITLE SHEET
C02	EXISTING CONDITIONS
C03	DEMOLITION PLAN
C04	PUD LAYOUT
A1.04	FIRST FLOOR PLAN
A2.02	EXTERIOR ELEVATIONS

OWNER
SQUIRE ROAD PROPERTIES LLC
7379 SQUIRE COURT
WEST CHESTER, OH 45069
513 383 8167

OPTIONEE
TRI-STATE UMIYA DHARMA
123 BOGGS LN
CINCINNATI, OH 45246
513 771 2444

ENGINEER - ARCHITECT
CT CONSULTANTS
4420 COOPER ROAD SUITE 200
CINCINNATI, OH 45242
MLACHNIET@CTCONSULTANTS.COM
513 792 8410



ISSUED FOR: PUD SUBMITTAL	ISSUE DATE:	SCALE:	DESIGNED BY:	DRAWN BY:	CHECKED BY:
	08/19/24	AS SHOWN	MLAC	MLAC	MLAC

NO	REVISION	DATE

**7379 SQUIRE COURT
REZONE**
7379 SQUIRE COURT, WEST CHESTER, OH 45069

TITLE SHEET



PROJECT NO.	242140
DISCIPLINE	CIVIL
SHEET NAME	C01
SHEET	1
OF	4

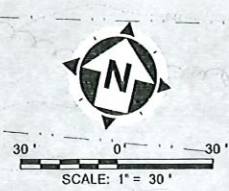
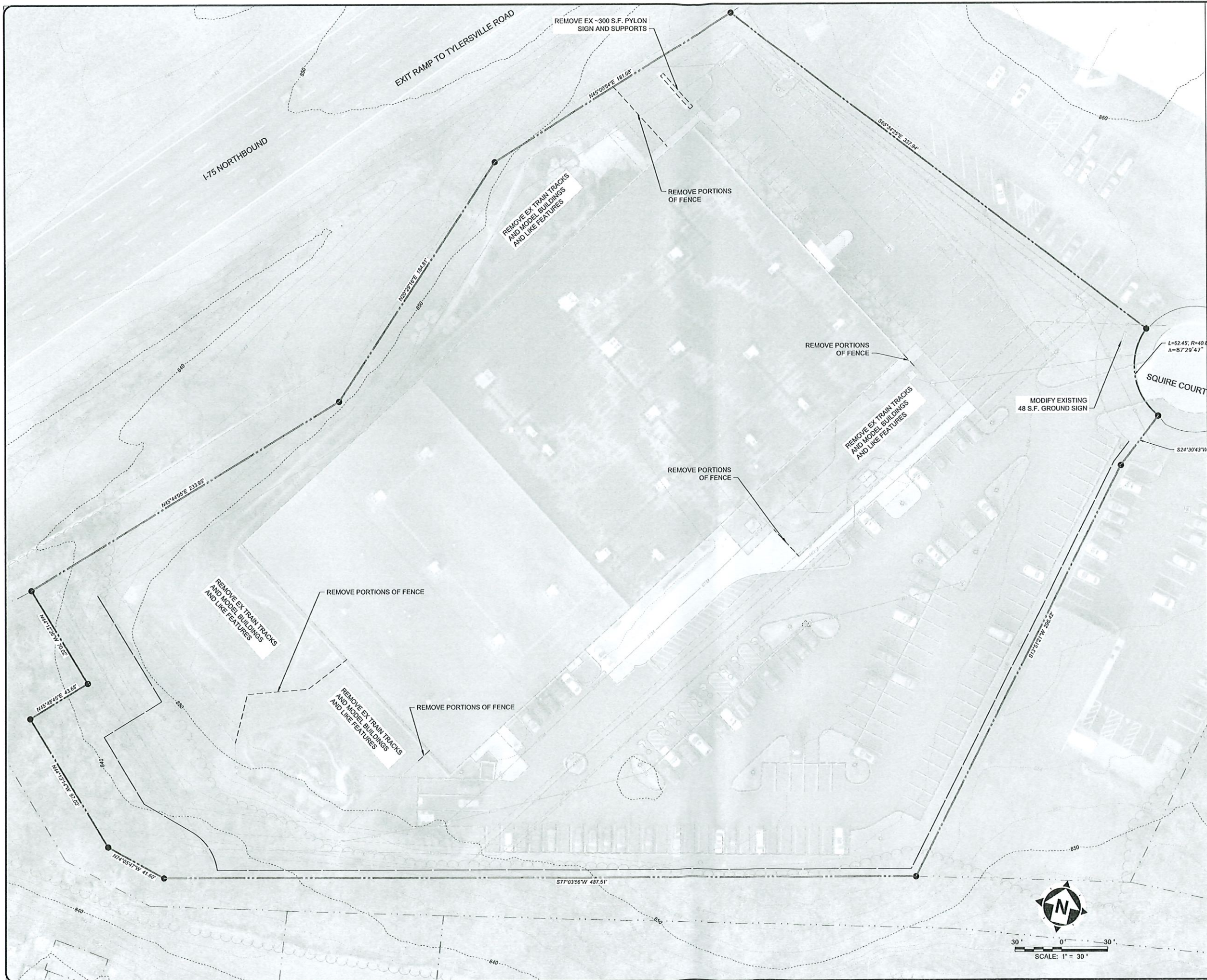



 your trusted advisor
CONSULTANTS
 engineers
 architects
 planners

NO	REVISION	DATE

ISSUED FOR: PUD SUBMITTAL	08/19/24
ISSUE DATE:	08/19/24
SCALE:	AS SHOWN
DESIGNED BY:	MLAC
DRAWN BY:	MLAC
CHECKED BY:	MLAC

7379 SQUIRE COURT
REZONE
7379 SQUIRE COURT, WEST CHESTER, OH 45069

DEMOLITION PLAN

PROJECT NO.	242140
DISCIPLINE	CIVIL
SHEET NAME	C03
SHEET	OF
3	4

H:\2024\24140\CIVIL\BASE\242140 - PUD PLAN\2415 - DEMOLITION - 8-15-2024 11:20 AM - MORN.LACHNET

