

West Chester

— OHIO —

Trustees Meeting Agenda November 14, 2023

Trustees

Ann Becker, Chair
Lee Wong
Mark S. Welch

Fiscal Officer

Bruce Jones
Administrator
Larry D. Burks

5:00 P.M.

Regular Meeting

Mrs. Becker

- Convene
- Roll Call
- Pledge

Executive Session

Property, personnel & pending litigation with Legal Counsel

Citizen's Comments

(2 minutes per person limited to a total of 10 minutes)

Mrs. Becker

Presentations

- A. Ryan Holiday - Ohio Auditor of State Award with Distinction

Mrs. Becker

Action Items - For approval by motion

- B. Motion to approve Trustee Meeting Minutes - October 24, 2023
- C. Motion to approve Trustee Special Meeting Minutes - November 2, 2023
- D. Motion to approve payment of bills - October 16, 2023 through November 3, 2023

Mr. Burks

Requisitions - Greater than \$7,500.00

- | | | |
|---------|--------------|--|
| 1. Adm | \$379,729.00 | Ohio Township Association Risk Management Authority (OTARMA) - Purchase liability and property insurance coverage |
| 2. Fire | \$ 17,687.00 | Path Master, Inc. - Purchase equipment for pre-emption lighting control devices (CIP 1668) |
| 3. Fire | \$ 17,085.00 | Capitol Electric Line Builders - Install pre-emption lighting control devices (CIP 1668) |
| 4. Fire | \$ 9,350.00 | Darrin Snyder - Paint exterior metal surfaces of Station 72 and Station 75 (CIP 1683) |
| 5. PIE | \$ 12,814.00 | The Plant Detail - Purchase holiday decorating service for 1823 Plaza, The Square and Township Administration Building/Fire Headquarters |

November 14, 2023

- 6. Police \$ 35,000.00 Emcor Facilities Services, Inc. - Paint and install carpet at the Police Department (CIP 1918)
- 7. Services \$ 225,000.00 Morton Salt, Inc. - Purchase road salt for 2023-2024 winter season
- 8. Services \$ 58,685.00 Rush Truck Centers of Ohio - Purchase 2023 Ford F450 truck cab and chassis for fleet replacement (CIP 1867)
- 9. Services \$ 18,000.00 Univar Solutions USA, Inc. - Purchase calcium chloride for 2023-2024 winter season

Mr. Burks Personnel Items

- 10. Police Hire Cassie Csendes to the position of Police Officer effective February 5, 2024 at the bi-weekly rate of \$2,713.97

Mr. Burks Business Items

- 11. Adm Motion to apply for Ohio Township Association Risk Management Authority (OTARMA) MORE Grant; and, authorize Township Administrator to accept said grant if awarded
- 12. Adm Motion to apply for Ohio Township Association Risk Management Authority (OTARMA) Police and Fire Grant; and, authorize Township Administrator to accept said grant if awarded
- 13. Adm Motion to re-appoint Larry D. Burks, Township Administrator, and Mr. Bruce Jones, West Chester resident, as the West Chester Township representatives to the Butler County Transportation Improvement District (TID) Board
- 14. Adm Motion to approve agreement between West Chester Township Board of Trustees and Butler County, Ohio for continued use of space at West Chester Safety Services Building at a cost of \$3,333.33 per month; and, authorize Township Administrator to make non-substantive changes with Law Director approval and execute said agreement
- 15. Adm Motion to approve Resolution 44-2023 amending the Township 2023 Permanent Appropriations
- 16. Comm Dev Motion to approve Resolution 45-2023 Authorizing the Acceptance of the Proposed Settlement Agreement Resolving West Chester Township's Zoning Enforcement Case Against the Property Located at 8295 Grinn Drive, West Chester, Ohio 45069
- 17. Police Motion not to object to a TRFO C1, C2, D6 liquor permit from IYS Ventures LLC dba I Mart Stores, 9171 Union Center Boulevard to Leanne Investment LLC dba I Mart Stores, 9171 Union Center Boulevard

First Reading of Resolutions & Reading of Emergency Resolutions

- 18. 1st Reading Resolution 46-2023 approving Zoning Map Amendment for Case # ZMA07-23 McNally Property (To be read at public hearing)
- *19. Emergency Reading Motion to approve Emergency Resolution 47-2023 authorizing the removal of snow and ice from undedicated roads in accordance with Ohio Revised Code section 505.82 and pursuant to Limited Home Rule Authority provided under Ohio Revised Code chapter 504 and declaring an emergency and dispensing with the second reading

Citizen's Comments

Second Reading & Vote on Pending Resolutions & Vote on Emergency Resolutions

- * Emergency Reading Vote on Emergency Resolution No. 47-2023
- 20. 2nd Reading Motion to approve Resolution 42-2023 Implementing Sections 3735.65 through 3735.70 of the Ohio Revised Code; Establishing and Describing the Boundaries of the West Chester Township Community Reinvestment Area; Designating a Housing Officer to Administer the Program; Creating a Community Reinvestment Housing Council; and Creating a Tax Incentive Review Council

Discussion Items & Elected Official Comments

Public Hearing 6:00 P.M.

Case # ZMA07-23 McNally Property

Adjourn

AGENDA ITEM COVER SHEET



Trustee Meeting Date:	Agenda Item Type:
November 14, 2023	Presentation Item
Submitted By:	
Larry D. Burks, Township Administrator	

Motion:
Ryan Holiday - Ohio Auditor of State Award with Distinction

Background:

Finance	Budgeted Item:	N/A;	
	CIP #:		
	TIF Info:		
	Purchase Order:		Total Encumbrance:

AGENDA ITEM COVER SHEET



Trustee Meeting Date:	Agenda Item Type:
November 14, 2023	Action Item
Submitted By:	
Larry D. Burks, Township Administrator	

Motion:
Motion to approve Trustee Meeting Minutes - October 24, 2023

Background:

Finance	Budgeted Item:	N/A;		
	CIP #:			
	TIF Info:			
	Purchase Order:		Total Encumbrance:	\$.00

Record of Proceedings: October 24, 2023
West Chester Township Board of Trustees - Regular Meeting

Convene: Chairperson Becker convened the meeting at 5:00 p.m.

Roll Call: Mrs. Becker, Mr. Wong, and Mr. Welch responded.

Pledge of Allegiance: Repeated by those present.

At 5:01 p.m., Mr. Wong motioned to recess the Regular meeting and go into Executive Session with legal counsel for the purpose of: (1) Preparing for, conducting, or reviewing negotiations or bargaining sessions with public employees concerning their compensation or other terms and conditions of their employment. O.R.C. 121.22(G)(4); (2) Consider confidential information related to the marketing plans, specific business strategy, production techniques, trade secrets, or personal financial statements of an applicant for economic development assistance or negotiations with other political subdivisions respecting requests for economic development assistance. The information to be discussed is directly related to a request for economic development assistance or involves public infrastructure improvements or the extension of utility services that are directly related to an economic development project. O.R.C. 121.22(G)(8). Before voting to enter executive session, Mrs. Becker asked Mr. Jones for a roll call to determine that executive session is necessary to protect the interests of the applicant or the possible investment or expenditure of public funds to be made in connection with the economic development project and that the criteria specified in O.R.C. 121.22(G)(8)(a) and (b) apply. Roll call conducted and the Trustees responded affirmatively unanimously. On Mr. Wong's motion to recess to Executive Session, Mr. Welch seconded the motion. Discussion: none. **Motion carried unanimously.**

Post Executive Session/ Adjournment

MOTION made at 5:58 p.m. by Mr. Welch to adjourn the Executive Session and resume the regularly scheduled meeting, seconded by Mr. Wong. Discussion: none. **Motion carried unanimously.**

MOTION made by Mr. Wong, seconded by Mr. Welch, to amend the agenda so as to move Personnel Items before Requisitions. Discussion: none. **Motion carried unanimously.**

Citizen's Comments

Sangita Desai, 4330 Tyler Estates Drive, gave a summary of Hindu-Americans involvement in society, invited everyone to celebrate and recognize October as Hindu Heritage Month.

Tom Racic, 4172 Lighthouse Lane, speaking as the President of the Villages of Providence HOA, asked the Trustees to approve Requisition Item 4. He said there's significant light and sound extending from warehouses abutting homes in his HOA and this item would enable the purchase and installation of trees to mitigate the light and sound encroaching on the subject homes.

Presentations

There were no presentations.

Action Items – For Approval by Motion

MOTION made by Mr. Wong, seconded by Mr. Welch, to approve the Trustee Meeting Minutes for October 10, 2023. Discussion: none. **Motion carried.** Mrs. Becker abstained.

MOTION made by Mr. Welch, seconded by Mr. Wong, to approve payment of bills. Discussion: none. **Motion carried unanimously.**

Personnel Items

Ms. Brown introduced the Personnel Items consisting of: (1) hiring Eli Jackson to the position of Police Officer effective October 30, 2023 at the bi-weekly rate of \$2,713.97, (2) hiring Jeff Smith to the position of Laborer Operator effective October 23, 2023 at the hourly rate of \$19.94. These were identified on the agenda as Personnel Items 5 and 6 respectively.

MOTION made by Mr. Wong, to approve Personnel Items 5 and 6, seconded by Mr. Welch. Discussion: The Trustees expressed their praise for the West Chester Township Police Department, their expectations of Mr. Jackson, and appreciation to Mr. Jackson and Mr. Smith for their service. **Motion carried unanimously.**

Thereupon, Mr. Jones administered the Oath of Office to Mr. Jackson accompanied by Chief Herzog and Assistant Chief Rebholz.

Action Items – For Approval by Motion

MOTION made by Mr. Welch, seconded by Mr. Wong, to remove Item 4 so as to vote on it separately. Discussion: none. **Motion carried unanimously.**

Mr. Burks submitted the following requisitions greater than \$7,500:

Requisitions – Greater than \$7,500.00

- 1. Adm \$45,483.10 Frost Brown Todd LLC - Legal Services through September 30, 2023
(various departments)
- 2. CIT \$19,921.39 CDW Government, Inc. - Replace township email spam filter (CIP#
1771)
- 3. CIT \$19,129.60 CDW Government, Inc. - Replace township email archive system
(CIP# 1771)

MOTION made by Mr. Wong, seconded by Mr. Welch, to approve payment of requisitions 1 through 3. Discussion: none. **Motion carried unanimously.**

- 4. Comm Dev \$22,000.00 Pinecrest Nursery – Purchase and install landscaping for
West Chester Trade Center

MOTION made by Mr. Welch, seconded by Mr. Wong, to approve payment of requisition 4. Discussion: Mrs. Becker invited Community Development Director Aaron Wiegand to address the Board. He provided background on the matter of light and sound impacting homes in the abutting HOA and experience in previous comparable circumstances. He answered additional questions from the Trustees. Discussion: Mr. Welch was concerned with addressing an issue after changed circumstances and Mrs. Becker said the changed circumstances were the reason to intervene. Mr. Welch said development entails inevitable changed circumstances and we risk setting precedent if we intervene retroactively. Mr. Wong related his personal experience with noise behind his home, adding “You just have to learn to live with it”. **Motion denied unanimously.**

Business Items

MOTION made by Mr. Welch, seconded by Mr. Wong, to approve Resolution 40-2023 amending the Township 2023 Permanent Appropriations. Discussion: none. **Motion carried unanimously.**

MOTION made by Mr. Welch, seconded by Mr. Wong, to authorize Township Administrator to enter into energy supply service agreement for West Chester Township facilities, not to exceed 6.3¢/kWh for a term not to exceed 24 months, commencing on the December 2023 meter read date; and, authorize Township Administrator to make non-substantive changes with Law Director approval, and execute said agreement.

Discussion: Prior to Discussion, Ms. Brown clarified for Mrs. Becker that the rate at issue is 6.3 cents/kWh, and confirmed for Mr. Wong that residents have the option of opting out of the program, otherwise they are in the program by default. **Motion carried unanimously.**

MOTION made by Mr. Welch, seconded by Mr. Wong, to approve Resolution 41-2023 accepting the Agreed Entry with Candelaria Lopez Noriega and Daisy Escobedo for the properties located at 6963 Tylersville Road; 6975 Tylersville Road; and 7821 Second Street. Discussion: none. **Motion carried unanimously.**

MOTION made by Mr. Wong, seconded by Mr. Welch, to approve Resolution 43-2023 declaring Surplus Items for disposal. Discussion: none. **Motion carried unanimously.**

First Reading of Resolutions & Reading of Emergency Resolutions

Ms. Brown read Resolution 42-2023 Implementing Sections 3735.65 through 3735.70 of the Ohio Revised Code; Establishing and Describing the Boundaries of the West Chester Township Community Reinvestment Area; Designating a Housing Officer to Administer the Program; Creating a Community Reinvestment Housing Council; and Creating a Tax Incentive Review Council. The Board had no questions.

Citizen's Comments

There were no citizen's comments.

Second Reading & Vote on Pending Resolutions & Vote on Emergency Resolutions

There were no second readings, or votes on pending resolutions or emergency resolutions.

Discussion Items & Elected Official Comments

Mrs. Becker recognized Halloween as being on the 31st and Pumpkin Fest festivities the previous Saturday.

Mr. Welch congratulated Mr. Burks for being recognized in the list Top 500 Executives in Ohio. Mr. Wong recognized another award for West Chester as being *Best Community to do Business* in Ohio, presented by Ohio Business magazine.

Mr. Jones gave an account of the Butler County Auditor's Town hall the previous Thursday. He also said West Chester Township would again be receiving the Ohio Auditor of State Award with Distinction for excellence in financial record keeping at the next regular Trustee meeting.

Adjournment

MOTION made at 6:43 p.m. by Mr. Welch, seconded by Mr. Wong, to adjourn the October 24th meeting. Discussion: none. **Motion carried unanimously.**

Respectfully Submitted,

Approved,

Bruce Jones, Fiscal Officer

Ann Becker, Chairperson

AGENDA ITEM COVER SHEET



Trustee Meeting Date:	Agenda Item Type:
November 14, 2023	Action Item
Submitted By:	
Larry D. Burks, Township Administrator	

Motion:
Motion to approve Trustee Special Meeting Minutes - November 2, 2023

Background:

Finance	Budgeted Item:	N/A;	
	CIP #:		
	TIF Info:		
	Purchase Order:		Total Encumbrance:

Record of Proceedings: November 2, 2023
West Chester Township Board of Trustees - Special Meeting

Convene: Chairperson Becker convened the meeting at 10:00 a.m.
Roll Call: Mrs. Becker, Mr. Wong, and Mr. Welch responded.
Pledge of Allegiance: Repeated by those present.

Business Items

MOTION made by Mr. Wong, seconded by Mr. Welch, to approve contract and premium rates for medical and dental insurance coverage with Aetna for January 1, 2024 through December 31, 2024; and, authorize Township Administrator to make non-substantive changes with Law Director approval and execute said contract.

Discussion: Mr. Welch expressed his appreciation for the negotiations performed by our administration and staff. **Motion carried unanimously.**

Adjournment

MOTION made at 10:05 a.m. by Mr. Welch, seconded by Mr. Wong, to adjourn the November 2, 2023 Special meeting. Discussion: none. **Motion carried unanimously.**

Respectfully Submitted,

Approved,

Bruce Jones, Fiscal Officer

Ann Becker, Chairperson

AGENDA ITEM COVER SHEET



Trustee Meeting Date:	Agenda Item Type:
November 14, 2023	Action Item
Submitted By:	
Larry D. Burks, Township Administrator	

Motion:
Motion to approve payment of bills - October 16, 2023 through November 3, 2023

Background:

Finance	Budgeted Item:	N/A;	
	CIP #:		
	TIF Info:		
	Purchase Order:		Total Encumbrance:

AP CHECK RECONCILIATION REGISTER

FOR CASH ACCOUNT: 9999-00-0000-10110-000000-000000

FOR: All Except Stale

CHECK #	CHECK DATE	TYPE	VENDOR NAME	UNCLEARED	CLEARED	BATCH	CLEAR DATE
1209	10/16/2023	MANUAL	002837 First Financial Bank Cred		-6.85	1	10/17/2023
	INVOICE NO		ACCOUNT	AMOUNT			
	Fin Credit Rds 8/30		1010-AD-AD00-56050-000000-	-6.85			
1210	10/16/2023	MANUAL	002837 First Financial Bank Cred		-5.09	1	10/17/2023
	Fin credit Rds 7/30		1010-AD-AD00-56050-000000-	-5.09			
1211	10/16/2023	MANUAL	002837 First Financial Bank Cred		33.53	1	10/17/2023
	UPS 9/11/23		2010-RD-RD00-53730-000000-	33.53			
1212	10/16/2023	MANUAL	002837 First Financial Bank Cred		392.65	1	10/17/2023
	Hoffman 9/21/23		2010-RD-RD00-53560-000000-	392.65			
1213	10/16/2023	MANUAL	002837 First Financial Bank Cred		300.00	1	10/17/2023
	APWA 9/25/23		1010-PK-PK00-53410-000000-	100.00			
	APWA 9/25/23		2010-RD-RD00-53410-000000-	200.00			
1214	10/16/2023	MANUAL	002837 First Financial Bank Cred		-3.17	1	10/17/2023
	Fin credit CD 7/30		1010-AD-AD00-56050-000000-	-3.17			
1215	10/16/2023	MANUAL	002837 First Financial Bank Cred		168.75	1	10/17/2023
	LandsEnd 9/7/23		1010-CD-CD00-54720-000000-	168.75			
1216	10/16/2023	MANUAL	002837 First Financial Bank Cred		349.95	1	10/17/2023
	Ikea 9/15/23		1010-CD-CD00-54010-000000-	349.95			
1217	10/16/2023	MANUAL	002837 First Financial Bank Cred		10.00	1	10/17/2023
	GoToCom 9/21/23		1010-CD-CD00-55020-000000-	10.00			
1218	10/16/2023	MANUAL	002837 First Financial Bank Cred		63.23	1	10/17/2023
	Kroger 9/19/23		2100-FD-FD00-54530-000000-	63.23			
1219	10/16/2023	MANUAL	002837 First Financial Bank Cred		-15.34	1	10/17/2023
	Fin credit 8/20/23		1010-AD-AD00-56050-000000-	-15.34			
1220	10/16/2023	MANUAL	002837 First Financial Bank Cred		587.40	1	10/17/2023
	fireemsbooks 8/31/23		2100-FD-FD00-53410-000000-	587.40			
1222	10/16/2023	MANUAL	002837 First Financial Bank Cred		106.79	1	10/17/2023
	Ramco 9/1/23		2100-FD-FD00-53510-000000-	106.79			
1223	10/16/2023	MANUAL	002837 First Financial Bank Cred		59.84	1	10/17/2023
	WM SuperCtr 9/12/23		2100-FD-FD00-54530-000000-	59.84			
1224	10/16/2023	MANUAL	002837 First Financial Bank Cred		63.58	1	10/17/2023
	Ramco 9/13/23		2100-FD-FD00-53510-000000-	63.58			
1225	10/16/2023	MANUAL	002837 First Financial Bank Cred		675.00	1	10/17/2023
	Endeavor 9/20/23		2100-FD-FD00-53410-000000-	675.00			

AP CHECK RECONCILIATION REGISTER

FOR CASH ACCOUNT: 9999-00-0000-10110-000000-000000

FOR: All Except Stale

CHECK #	CHECK DATE	TYPE	VENDOR NAME	UNCLEARED	CLEARED	BATCH	CLEAR DATE
1226	10/16/2023	MANUAL	002837 First Financial Bank Cred		64.07	1	10/17/2023
	INVOICE NO		ACCOUNT	AMOUNT			
	Ramco 9/25/23		2100-FD-FD00-53510-000000-		64.07		
1227	10/16/2023	MANUAL	002837 First Financial Bank Cred		180.00	1	10/17/2023
	CLIA lab 9/26/23		2100-FD-FD00-53190-000000-		180.00		
1228	10/17/2023	MANUAL	003159 Charter Communications	36.89			
	0227194 09/30/23		2030-RD-RD00-55060-000000-		36.89		
1229	10/17/2023	MANUAL	002837 First Financial Bank Cred		-7.42	1	10/18/2023
	Fin credit 8/30/23		1010-AD-AD00-56050-000000-		-7.42		
1230	10/17/2023	MANUAL	002837 First Financial Bank Cred		-4.45	1	10/18/2023
	Fin creditC 7/30/23		1010-AD-AD00-56050-000000-		-4.45		
1231	10/17/2023	MANUAL	002837 First Financial Bank Cred		31.22	1	10/18/2023
	WM Superctr 9/13/23		1010-PK-PK10-54550-000000-		31.22		
1232	10/17/2023	MANUAL	002837 First Financial Bank Cred		6.94	1	10/18/2023
	Michaels 9/25/23		1010-PK-PK10-56030-NTRBSK-		6.94		
1233	10/17/2023	MANUAL	002837 First Financial Bank Cred		7.44	1	10/18/2023
	Fedex 9/27/23		2010-RD-RD00-53730-000000-		7.44		
1234	10/17/2023	MANUAL	000319 Home Depot	56.02			
	8010186		1010-PK-PK04-54550-000000-		56.02		
1235	10/17/2023	MANUAL	002837 First Financial Bank Cred		183.10	1	10/18/2023
	Loews 8/29/23		2100-FD-FD00-53410-000000-		183.10		
1236	10/17/2023	MANUAL	002837 First Financial Bank Cred		-6.99	1	10/18/2023
	Fin creditD 7/30/23		1010-AD-AD00-56050-000000-		-6.99		
1237	10/17/2023	MANUAL	002837 First Financial Bank Cred		75.00	1	10/18/2023
	Lowe's 9/15/23		2100-FD-FD00-53530-000000-		75.00		
1238	10/20/2023	MANUAL	003159 Charter Communications	386.12			
	0198858100823		2070-PI-PI00-55060-000000-		386.12		
1239	10/20/2023	MANUAL	002837 First Financial Bank Cred	209.00			
	Dirigosoftw 8/30/23		2090-PD-PD00-54830-000000-		209.00		
1240	10/20/2023	MANUAL	002837 First Financial Bank Cred	175.00			
	PSI Services 8/31/23		2250-PD-PD00-53410-000000-		175.00		
1241	10/20/2023	MANUAL	002837 First Financial Bank Cred	73.49			
	Badgeandwallet 9/5		2090-PD-PD00-54720-000000-		73.49		
1242	10/20/2023	MANUAL	002837 First Financial Bank Cred	-59.12			

AP CHECK RECONCILIATION REGISTER

FOR CASH ACCOUNT: 9999-00-0000-10110-000000-000000

FOR: All Except Stale

CHECK #	CHECK DATE	TYPE	VENDOR NAME	UNCLEARED	CLEARED	BATCH	CLEAR DATE
	Fin credite 7/30/23		1010-AD-AD00-56050-000000-		-59.12		
1243	10/20/2023	MANUAL	002837 First Financial Bank Cred	324.70			
	INVOICE NO		ACCOUNT		AMOUNT		
	Drury Co1 9/6/23		2090-PD-PD00-53410-000000-		324.70		
1244	10/20/2023	MANUAL	002837 First Financial Bank Cred	432.48			
	Columbus 9/6/23		2090-PD-PD00-53410-000000-		432.48		
1245	10/20/2023	MANUAL	002837 First Financial Bank Cred	155.10			
	Embassy 9/18/23		2090-PD-PD00-53410-000000-		155.10		
1246	10/20/2023	MANUAL	002837 First Financial Bank Cred	335.76			
	Applespice 9/18/23		2090-PD-PD00-54530-000000-		335.76		
1247	10/20/2023	MANUAL	002837 First Financial Bank Cred	14.39			
	Firstwatch 9/19/23		2090-PD-PD00-54530-000000-		14.39		
1248	10/20/2023	MANUAL	002837 First Financial Bank Cred	175.00			
	PSI Services 9/22/23		2250-PD-PD00-53410-000000-		175.00		
1249	10/20/2023	MANUAL	002837 First Financial Bank Cred	620.40			
	Embassy 9/22/23		2090-PD-PD00-53410-000000-		620.40		
1250	10/20/2023	MANUAL	002837 First Financial Bank Cred	175.00			
	PSI Services 9/22		2250-PD-PD00-53410-000000-		175.00		
1251	10/20/2023	MANUAL	002837 First Financial Bank Cred	30.00			
	DeltaAirBagfee 9/4		2070-PI-PI00-53410-000000-		30.00		
1252	10/20/2023	MANUAL	002837 First Financial Bank Cred	30.00			
	DeltaAirBagfeeA 9/4		2070-PI-PI00-53410-000000-		30.00		
1253	10/20/2023	MANUAL	002837 First Financial Bank Cred	-9.66			
	Fin creditF 7/30/23		1010-AD-AD00-56050-000000-		-9.66		
1254	10/20/2023	MANUAL	002837 First Financial Bank Cred	763.56			
	Hyatt 9/8/23		2070-PI-PI00-53410-000000-		763.56		
1255	10/20/2023	MANUAL	002837 First Financial Bank Cred	706.53			
	Hyatt Hines 9/8/23		2070-PI-PI00-53410-000000-		706.53		
1256	10/20/2023	MANUAL	002837 First Financial Bank Cred	30.00			
	DeltaAirBagfee 9/9		2070-PI-PI00-53410-000000-		30.00		
1257	10/20/2023	MANUAL	002837 First Financial Bank Cred	30.00			
	DeltaAirBagfee 9/11		2070-PI-PI00-53410-000000-		30.00		
1258	10/20/2023	MANUAL	000319 Home Depot	48.12			
	2010963		1010-PK-PK03-53530-000000-		36.38		

AP CHECK RECONCILIATION REGISTER

FOR CASH ACCOUNT: 9999-00-0000-10110-000000-000000

FOR: All Except Stale

CHECK #	CHECK DATE	TYPE	VENDOR NAME	UNCLEARED	CLEARED	BATCH	CLEAR DATE
	2010963		2010-RD-RD00-54550-000000-		11.74		
1259	10/20/2023	MANUAL	000319 Home Depot	86.98			
	INVOICE NO		ACCOUNT		AMOUNT		
	8211837		2090-PD-PD00-54550-000000-		86.98		
1260	10/20/2023	MANUAL	000319 Home Depot	897.68			
	7971007		2100-FD-FD00-54010-000000-		897.68		
167420	10/20/2023	PRINTED	000615 Altafiber	775.57			
	860-5544	Oct 23	2100-FD-FD00-55010-000000-		100.94		
	860-9226	Oct 23	1010-PK-PK13-55010-000000-		75.78		
	860-1946	Oct 23	1010-PK-PK11-55010-000000-		98.22		
	874-2443	Oct 23	2100-FD-FD00-55010-000000-		197.42		
	779-0071	Oct 23	1010-AD-AD00-55010-000000-		176.18		
	682-2529	Oct 23	2100-FD-FD00-55010-000000-		127.03		
167421	10/20/2023	PRINTED	004008 Butler County Water & Sew	7,091.25			
	2006330	Oct 23	2100-FD-FD00-55030-000000-		167.78		
	2013795	Oct 23	1010-PK-PK04-55030-000000-		37.90		
	2013796	Oct 23	1010-PK-PK04-55030-000000-		8.64		
	2000563	Oct 23	1010-AD-AD00-55040-000000-		66.68		
	2000563	Oct 23	2070-PI-PI00-55040-000000-		9.10		
	2000564	Oct 23	1010-AD-AD00-55030-000000-		35.94		
	2000564	Oct 23	2050-CE-CE00-55030-000000-		11.97		
	2000564	Oct 23	2070-PI-PI00-55030-000000-		4.69		
	2000564	Oct 23	2090-DS-DS00-55030-000000-		16.40		
	2000564	Oct 23	2100-DS-DS00-55030-000000-		16.40		
	2000564	Oct 23	2100-FD-FD00-55030-000000-		174.95		
	2002286	Oct 23	2100-FD-FD00-55030-000000-		178.26		
	2014474	Oct 23	2100-FD-FD00-55030-000000-		95.26		
	2027757	Oct 23	1010-AD-AD00-55030-000000-		21.15		
	2027757	Oct 23	1010-CD-CD00-55030-000000-		14.09		
	2027757	Oct 23	2030-RD-RD00-55030-000000-		155.03		
	2027757	Oct 23	2090-PD-PD00-55030-000000-		514.44		
	2027759	Oct 23	2100-FD-FD00-55030-000000-		192.00		
	2051667	Oct 23	1010-PK-PK12-55030-000000-		304.81		
	2049236	Oct 23	1010-PK-PK11-55030-000000-		149.65		
	2041335	Oct 23	1010-PK-PK13-55030-000000-		4,916.11		
167422	10/20/2023	PRINTED	003253 Change Healthcare Tech En	6,357.84			
	MD12942		2110-EM-EM00-53190-000000-		6,357.84		
167423	10/20/2023	PRINTED	000641 Duke Energy	4,717.00			
	FRS-0048305		5070-LT-LT03-55040-000000-		4,717.00		
167424	10/20/2023	PRINTED	001334 Duke Energy	183.95			
	910134027453	Oct 23	1010-LT-LT00-55040-000000-		70.14		
	910117892680	Oct 23	1010-PK-PK04-55040-000000-		91.65		
	910117893186	Oct 23	1010-PK-PK04-55040-000000-		22.16		

AP CHECK RECONCILIATION REGISTER

FOR CASH ACCOUNT: 9999-00-0000-10110-000000-000000

FOR: All Except Stale

CHECK #	CHECK DATE	TYPE	VENDOR NAME	UNCLEARED	CLEARED	BATCH	CLEAR DATE
167425	10/20/2023	PRINTED	003611 Fire Department Service &	27,240.75			
			INVOICE NO	ACCOUNT	AMOUNT		
			8729	2100-FD-FD00-57050-000000-	27,240.75		
167426	10/20/2023	PRINTED	000585 Grainger Inc.	117.79			
			9846460849	2100-FD-FD00-53530-000000-		117.79	
167427	10/20/2023	PRINTED	000753 Great American Financial	495.00			
			10/20/23	2090-00-0000-22520-000000-000000		495.00	
167428	10/20/2023	PRINTED	000344 Jackson Construction Inc.	7,488.40			
			281	1010-AD-AD00-57010-000000-		7,488.40	
167429	10/20/2023	PRINTED	002253 Jamie's Mulch And Topsoil	624.03			
			A27623	1010-PK-PK03-53530-000000-		192.13	
			A27623	1010-PK-PK04-53530-000000-		192.13	
			A27631	2070-PI-PI00-56030-PUMPKN-		239.77	
167430	10/20/2023	PRINTED	000353 John Dsuban Spring Servic	1,251.15			
			0156248-IN	2010-RD-RD00-53510-000000-		1,251.15	
167431	10/20/2023	PRINTED	004050 Kellie Byrd	162.06			
			Byrd 10/06/23	1010-AD-HR00-56040-000000-		85.00	
			Byrd 10/12/23 A	1010-AD-HR00-56040-000000-		29.00	
			Byrd 10/12/23 B	2740-00-0000-53190-000000-		48.06	
167432	10/20/2023	PRINTED	002967 Michael S. Lyons	962.50			
			03-2023	2070-PI-PI00-53190-000000-		962.50	
167433	10/20/2023	PRINTED	000427 Miami Valley Regional Cri	600.00			
			FT1000018059	2250-PD-PD00-53410-000000-		600.00	
167434	10/20/2023	PRINTED	002776 Mike Castrucci Ford Inc	398.42			
			142254	2010-RD-RD00-53510-000000-		121.64	
			141635	2110-EM-EM00-53510-000000-		236.83	
			141669	2110-EM-EM00-53510-000000-		39.95	
167435	10/20/2023	PRINTED	000457 Noel's Plumbing Supply In	72.92			
			0202526-IN	2100-FD-FD00-53530-000000-		72.92	
167436	10/20/2023	PRINTED	001256 National Tactical officer	1,530.00			
			9310	2250-PD-PD00-53410-000000-		765.00	
			9309	2250-PD-PD00-53410-000000-		765.00	
167437	10/20/2023	PRINTED	000462 Ohio Association of Chief	595.00			
			ED131	2250-PD-PD00-53410-000000-		205.00	
			ED130	2250-PD-PD00-53410-000000-		185.00	
			ED123	2250-PD-PD00-53410-000000-		205.00	

AP CHECK RECONCILIATION REGISTER

FOR CASH ACCOUNT: 9999-00-0000-10110-000000-000000

FOR: All Except Stale

CHECK #	CHECK DATE	TYPE	VENDOR NAME	UNCLEARED	CLEARED	BATCH	CLEAR DATE
167438	10/20/2023	PRINTED	000755 Ohio Public Employees Def	26,604.20			
			INVOICE NO ACCOUNT AMOUNT				
			Oh Dfrd 10/20/23 1010-00-0000-22520-000000-000000		4,245.00		
			Oh Dfrd 10/20/23 2090-00-0000-22520-000000-000000		13,433.52		
			Oh Dfrd 10/20/23 2100-00-0000-22520-000000-000000		6,720.68		
			Oh Dfrd 10/20/23 2110-00-0000-22520-000000-000000		200.00		
			Oh Dfrd 10/20/23 2040-00-0000-22520-000000-000000		1,710.00		
			Oh Dfrd 10/20/23 2070-00-0000-22520-000000-000000		295.00		
167439	10/20/2023	PRINTED	003923 Steve R Tysl	650.00			
	08/19/23	reissue	2070-PI-PI00-56030-CONCRT-		650.00		
167440	10/20/2023	PRINTED	000482 Pinecrest Nursery	617.00			
	3820		1010-PK-PK03-53530-000000-		308.50		
	3820		1010-PK-PK04-53530-000000-		308.50		
167441	10/20/2023	PRINTED	001267 Recker & Boerger	369.99			
	APLINVCS0171589		2100-FD-FD00-54010-000000-		369.99		
167442	10/20/2023	PRINTED	004172 Robert Obermeyer	77.46			
	Obermeyer 10/08/23		2090-PD-PD00-53410-000000-		77.46		
167443	10/20/2023	PRINTED	002495 Roto-Rooter	633.00			
	27-25304452		2100-FD-FD00-53530-000000-		633.00		
167444	10/20/2023	PRINTED	001329 Security Benefit Group	9,495.00			
	611021 10/20/23		1010-00-0000-22520-000000-000000		1,000.00		
	611021 10/20/23		2090-00-0000-22520-000000-000000		1,913.75		
	611021 10/20/23		2100-00-0000-22520-000000-000000		5,443.75		
	611021 10/20/23		2110-00-0000-22520-000000-000000		693.75		
	611021 10/20/23		2040-00-0000-22520-000000-000000		243.75		
	611021 10/20/23		5080-00-0000-22520-000000-000000		200.00		
167445	10/20/2023	PRINTED	004106 Treasurer of State of Ohi	90.00			
	VDFDF20230926-116		2100-FD-FD00-56050-000000-		90.00		
167446	10/20/2023	PRINTED	004016 Treasurer of State of Ohi	330.25			
	5370275		1010-AD-AD00-53530-000000-		165.13		
	5370275		2090-DS-DS00-53530-000000-		82.56		
	5370275		2100-DS-DS00-53530-000000-		82.56		
167447	10/20/2023	PRINTED	003835 Tyler Technologies Inc	2,608.00			
	045-439301		1010-AD-AD00-54820-000000-		1,450.05		
	045-439301		1010-CD-CD00-54820-000000-		44.34		
	045-439301		2010-RD-RD00-54820-000000-		104.32		
	045-439301		2070-PI-PI00-54820-000000-		23.47		
	045-439301		2090-DS-DS00-54820-000000-		39.12		
	045-439301		2090-PD-PD00-54820-000000-		438.14		
	045-439301		2100-DS-DS00-54820-000000-		39.12		
	045-439301		2100-FD-FD00-54820-000000-		456.40		

AP CHECK RECONCILIATION REGISTER

FOR CASH ACCOUNT: 9999-00-0000-10110-000000-000000

FOR: All Except Stale

CHECK #	CHECK DATE	TYPE	VENDOR NAME	UNCLEARED	CLEARED	BATCH	CLEAR DATE
	045-439301		2110-EM-EM00-54820-000000-		13.04		
167448	10/20/2023	PRINTED	003759 Unifirst Corporation	274.61			
	INVOICE NO		ACCOUNT		AMOUNT		
	1340218762		1010-PK-PK00-54550-000000-		33.02		
	1340218762		1010-PK-PK00-54720-000000-		22.04		
	1340218762		1010-SV-SV00-54720-000000-		24.59		
	1340218762		2010-RD-RD00-54550-000000-		16.16		
	1340218762		2010-RD-RD00-54720-000000-		164.35		
	1340218762		2050-CE-CE00-54720-000000-		14.45		
167449	10/20/2023	PRINTED	000577 Verizon wireless	7,238.55			
	9946368688		1010-AD-AD00-55020-000000-		473.83		
	9946368688		1010-CD-CD00-55020-000000-		234.71		
	9946368688		1010-SV-SV00-55020-000000-		162.96		
	9946368688		2030-RD-RD00-55020-000000-		659.54		
	9946368688		2050-CE-CE00-55020-000000-		40.74		
	9946368688		2070-SR-SR00-55020-000000-		51.82		
	9946368688		2070-PI-PI00-55020-000000-		243.18		
	9946368688		2090-DS-DS00-55020-000000-		72.19		
	9946368688		2090-PD-PD00-55020-000000-		2,794.23		
	9946368688		2100-DS-DS00-55020-000000-		72.19		
	9946368688		2100-FD-FD00-55020-000000-		2,433.16		
167450	10/20/2023	PRINTED	000582 VIP Printing Center	79.40			
	35340		2070-PI-PI00-53710-000000-		79.40		
400576	10/20/2023	EFT	001532 A-Plus Concrete & Excavat	30.00			
	11004		2010-RD-RD00-54550-IHCLVT-		30.00		
400577	10/20/2023	EFT	003376 Across The Street Product	830.00			
	INV14289		2100-FD-FD00-53410-000000-		415.00		
	INV14289-Hanifen		2100-FD-FD00-53410-000000-		415.00		
400578	10/20/2023	EFT	000012 ADP Inc.	3,627.62			
	643967514		1010-AD-AD00-53190-000000-		194.34		
	643967514		1010-CD-CD00-53190-000000-		129.56		
	643967514		1010-AD-AD02-53190-000000-		38.87		
	643967514		1010-PK-PK00-53190-000000-		38.87		
	643967514		1010-AD-AD03-53190-000000-		12.96		
	643967514		1010-SV-SV00-53190-000000-		51.82		
	643967514		2040-RD-RD00-53190-000000-		246.16		
	643967514		2050-CE-CE00-53190-000000-		38.87		
	643967514		2070-PI-PI00-53190-000000-		64.78		
	643967514		2090-DS-DS00-53190-000000-		103.64		
	643967514		2090-PD-PD00-53190-000000-		1,256.71		
	643967514		2100-DS-DS00-53190-000000-		103.64		
	643967514		2100-FD-FD00-53190-000000-		1,256.71		
	643967514		2110-EM-EM00-53190-000000-		77.73		
	643967514		5080-RD-RD00-53190-000000-		12.96		

AP CHECK RECONCILIATION REGISTER

FOR CASH ACCOUNT: 9999-00-0000-10110-000000-000000

FOR: All Except Stale

CHECK #	CHECK DATE	TYPE	VENDOR NAME	UNCLEARED	CLEARED	BATCH	CLEAR DATE
400579	10/20/2023	EFT	003800 ADW Acquisitions LLC	151.96			
		INVOICE NO	ACCOUNT		AMOUNT		
		18178302	2090-PD-PD00-53510-000000-		151.96		
400580	10/20/2023	EFT	002422 AFSCME Ohio Council 8, Lo	451.35			
	10/20/23	Dues	1010-00-0000-22510-000000-000000		53.10		
	10/20/23	Dues	2090-00-0000-22510-000000-000000		13.26		
	10/20/23	Dues	2100-00-0000-22510-000000-000000		13.28		
	10/20/23	Dues	2110-00-0000-22510-000000-000000		13.28		
	10/20/23	Dues	2040-00-0000-22510-000000-000000		305.33		
	10/20/23	Dues	5080-00-0000-22510-000000-000000		26.55		
	10/20/23	Dues	2050-00-0000-22510-000000-000000		26.55		
400581	10/20/2023	EFT	003337 Airgas, Inc.	219.79			
	5502417412		2110-EM-EM00-54550-000000-		219.79		
400582	10/20/2023	EFT	002035 Al-Joe's Inc	856.80			
	10/04/2023		2100-FD-FD00-54010-000000-		856.80		
400583	10/20/2023	EFT	002937 Alert-All Corp	2,110.00			
	223091131		2100-FD-FD00-54550-000000-		2,110.00		
400584	10/20/2023	EFT	003174 Amazon Fullfillment Servi	723.89			
	1RDH-PYH4-F7PT		2070-PI-PI00-56030-PUMPKN-		49.71		
	1VHK-P3NJ-6DRM		2090-PD-PD00-54510-000000-		99.20		
	1DXH-KTYL-WMC9		2100-FD-FD00-54550-000000-		299.90		
	1W6X-GQ11-VKGL		2100-FD-FD00-54550-000000-		29.79		
	1FHP-7MJG-H96P		2100-FD-FD00-54010-000000-		175.99		
	1VGW-N6T3-C7YV		2010-RD-RD00-53510-000000-		13.45		
	1VGW-N6T3-C7YV		2010-RD-RD00-54510-000000-		9.69		
	1CQ3-NXNV-YP9W		1010-AD-AD00-54510-000000-		46.16		
400585	10/20/2023	EFT	003870 Architectural Reclamation	13,336.99			
	2023-33		1010-PK-PK04-57010-000000-		13,262.94		
	2023-35		1010-PK-PK04-53530-000000-		74.05		
400586	10/20/2023	EFT	002488 Autozone Stores LLC	54.14			
	4519352153		1010-PK-PK00-53560-000000-		54.14		
400587	10/20/2023	EFT	003586 Brayden Barger	368.75			
	13		2070-PI-PI00-53190-000000-		368.75		
400588	10/20/2023	EFT	000116 Bethart Printing Services	77.00			
	55144		2070-PI-PI00-53710-000000-		77.00		
400589	10/20/2023	EFT	000117 Bethesda Healthcare Inc.	1,041.10			
	18691-462768		2090-PD-PD00-53230-000000-		196.00		
	9920-462766		2010-RD-RD00-53230-000000-		208.00		
	9788-462019		1010-AD-AD00-52210-000000-		43.70		

AP CHECK RECONCILIATION REGISTER

FOR CASH ACCOUNT: 9999-00-0000-10110-000000-000000

FOR: All Except Stale

CHECK #	CHECK DATE	TYPE	VENDOR NAME	UNCLEARED	CLEARED	BATCH	CLEAR DATE
	9788-462019		1010-CD-CD00-52210-000000-		23.00		
	INVOICE NO		ACCOUNT		AMOUNT		
	9788-462019		1010-PK-PK00-52210-000000-		6.90		
	9788-462019		1010-SV-SV00-52210-000000-		9.20		
	9788-462019		2040-RD-RD00-52210-000000-		47.73		
	9788-462019		2050-CE-CE00-52210-000000-		4.60		
	9788-462019		2070-PI-PI00-52210-000000-		11.50		
	9788-462019		2090-DS-DS00-52210-000000-		23.92		
	9788-462019		2090-PD-PD00-51010-000000-		220.22		
	9788-462019		2100-DS-DS00-52210-000000-		12.88		
	9788-462019		2100-FD-FD00-52210-000000-		231.15		
	9788-462019		5080-RD-RD00-52210-000000-		2.30		
400590	10/20/2023	EFT	003381 AAA Club Alliance Inc Car	161.48			
	112041482		2090-PD-PD00-53510-000000-		161.48		
400591	10/20/2023	EFT	000123 Bobcat Enterprises Inc.	100.77			
	P06292		2010-RD-RD00-53560-000000-		100.77		
	P05947		2010-RD-RD00-53560-000000-		380.18		
	P05968		2010-RD-RD00-53560-000000-		2,118.14		
	P05966		2010-RD-RD00-53560-000000-		-380.18		
	P06074		2010-RD-RD00-53560-000000-		-2,118.14		
400592	10/20/2023	EFT	000126 Bound Tree Medical LLC.	581.82			
	85124303		2110-EM-EM00-54550-000000-		581.82		
400593	10/20/2023	EFT	001471 CDW Government Inc.	2,988.21			
	Surface Pro 8 Credit		2090-PD-PD00-54810-000000-		-10.29		
	ZR00399368		2100-FD-FD00-54830-000000-		2,998.50		
400594	10/20/2023	EFT	003895 Lifestyle Publications LL	1,800.00			
	202311-00083097		2070-PI-PI00-56030-BICNTL-		1,800.00		
400595	10/20/2023	EFT	004169 Economics Center for Educ	7,625.00			
	14752		1010-AD-AD00-53190-VOAMSC-		7,625.00		
400596	10/20/2023	EFT	000634 Emcor Facilities Services	46,185.41			
	607091		1010-AD-AD00-53530-000000-		2,775.16		
	607091		1010-CD-CD00-53530-000000-		2,312.63		
	607091		2010-RD-RD00-53530-000000-		3,931.47		
	607091		2090-PD-PD00-53530-000000-		14,107.06		
	607092		1010-AD-AD00-53530-000000-		5,219.20		
	607092		2070-PI-PI00-53530-000000-		711.71		
	607093		1010-AD-AD00-53530-000000-		2,395.39		
	607093		2090-DS-DS00-53530-000000-		1,197.69		
	607093		2100-DS-DS00-53530-000000-		1,197.69		
	607095B		1010-PK-PK11-53530-000000-		2,500.00		
	607097		1010-AD-AD00-53530-000000-		218.87		
	607097		1010-CD-CD00-53530-000000-		182.39		
	607097		2010-RD-RD00-53530-000000-		310.06		

AP CHECK RECONCILIATION REGISTER

FOR CASH ACCOUNT: 9999-00-0000-10110-000000-000000

FOR: All Except Stale

CHECK #	CHECK DATE	TYPE	VENDOR NAME	UNCLEARED	CLEARED	BATCH	CLEAR DATE
607097			2090-PD-PD00-53530-000000-		1,112.58		
		INVOICE NO	ACCOUNT		AMOUNT		
		607095A	1010-PK-PK03-53530-000000-		339.34		
		607095A	1010-PK-PK04-53530-000000-		72.43		
		607095A	1010-PK-PK11-53530-000000-		909.53		
		607095A	1010-PK-PK12-53530-000000-		59.32		
		607096	2050-CE-CE00-53530-000000-		822.22		
		594434	2100-FD-FD00-53530-000000-		2,110.32		
		595056	2100-FD-FD00-53530-000000-		1,758.26		
		595950	2100-FD-FD00-53530-000000-		1,533.09		
		593565	2100-FD-FD00-53530-000000-		409.00		
400597	10/20/2023	EFT	001179 ESRI Inc.	18,135.00			
			2090-PD-PD00-54820-000000-		9,067.50		
			2100-FD-FD00-54820-000000-		9,067.50		
400598	10/20/2023	EFT	000261 Firecom	1,375.00			
			2100-FD-FD00-53560-000000-		1,375.00		
400599	10/20/2023	EFT	002825 First Choice Coffee Servi	203.15			
			2100-FD-FD00-54530-000000-		203.15		
400600	10/20/2023	EFT	000754 F.O.P. Lodge #186	2,017.50			
		FOP 186 10/20/23	2090-00-0000-22510-000000-000000		2,017.50		
400601	10/20/2023	EFT	002442 Fox Towing Inc.	190.00			
			2090-PD-PD00-53240-000000-		190.00		
400602	10/20/2023	EFT	000277 Galls, LLC	281.10			
			2100-FD-FD00-54720-000000-		281.10		
400603	10/20/2023	EFT	000280 Gateway Tire Company Inc.	671.76			
			2100-FD-FD00-53510-000000-		671.76		
400604	10/20/2023	EFT	001399 Jack Doheny Companies, In	127.30			
			2010-RD-RD00-53510-000000-		127.30		
400605	10/20/2023	EFT	002579 Kronos Incorporated	5.25			
			2100-FD-FD00-54830-000000-		5.25		
400606	10/20/2023	EFT	001462 Language Line Services	5.25			
			2100-FD-FD00-53190-000000-		5.25		
400607	10/20/2023	EFT	000416 Melvin Stone	749.95			
			2010-RD-RD00-54550-IHCRCK-		749.95		
400608	10/20/2023	EFT	002441 Menard, Inc.	57.96			
			1010-SV-SV00-53530-000000-		18.99		
			1010-SV-SV99-53560-000000-		38.97		

AP CHECK RECONCILIATION REGISTER

FOR CASH ACCOUNT: 9999-00-0000-10110-000000-000000

FOR: All Except Stale

CHECK #	CHECK DATE	TYPE	VENDOR NAME	UNCLEARED	CLEARED	BATCH	CLEAR DATE
400609	10/20/2023	EFT	000420 Metal Supermarkets	65.17			
	INVOICE NO		ACCOUNT		AMOUNT		
	1027779		1010-PK-PK00-53560-000000-		65.17		
400610	10/20/2023 0/10/2023-17	EFT	004159 Miami-Dade County Board o 2250-PD-PD00-53410-000000-	625.00	625.00		
400611	10/20/2023 209549 209978	EFT	000447 Murphy Supply Company 2100-FD-FD00-54550-000000- 2010-RD-RD00-54550-000000-	709.08	679.08 30.00		
400612	10/20/2023 2017 Chev Impala	EFT	000456 Nick's Towing 2090-PD-PD00-53240-000000-	325.00	325.00		
400613	10/20/2023 13205 13209	EFT	000604 Northcoast Products 2010-RD-RD00-54550-IHCRCK- 2010-RD-RD00-54550-IHCRCK-	1,186.45	448.35 738.10		
400614	10/20/2023 1738-300957 1738-300735 1738-300999 1738-298550 1738-302422 1738-302608	EFT	003478 O'Reilly Auto Enterprises 2090-PD-PD00-53510-000000- 1010-PK-PK00-53510-000000- 2090-PD-PD00-53510-000000- 2100-FD-FD00-53510-000000- 2010-RD-RD00-53510-000000- 2010-RD-RD00-53510-000000-	628.25	309.24 48.70 170.17 23.32 13.34 63.48		
400615	10/20/2023 332663976001 336306089001 336306089001	EFT	003831 ODP Business Solutions LL 2100-FD-FD00-54510-000000- 2090-PD-PD00-54510-000000- 2090-PD-PD00-54510-000000-	360.30	294.94 32.24 33.12		
400616	10/20/2023 950358 949001 950515 949782	EFT	000475 Overhead Door of Cincinna 2100-FD-FD00-53530-000000- 2100-FD-FD00-53530-000000- 2100-FD-FD00-53530-000000- 2100-FD-FD00-53530-000000-	2,047.29	246.25 270.00 1,005.00 526.04		
400617	10/20/2023 1083	EFT	003940 Pinpoint Behavioral Healt 2750-AD-AD00-53190-ARPAPS-	17,100.00	17,100.00		
400618	10/20/2023 1040669 Nov 23 1040669 Nov 23 1040669 Nov 23 1040669 Nov 23 1040669 Nov 23 1040669 Nov 23	EFT	002852 Principal Financial Group 1010-00-0000-22220-000000-000000 2090-00-0000-22220-000000-000000 2100-00-0000-22220-000000-000000 2110-00-0000-22220-000000-000000 2040-00-0000-22220-000000-000000 2070-00-0000-22220-000000-000000	4,919.72	634.72 1,982.64 1,728.18 259.20 126.98 188.00		
400619	10/20/2023 003518 10/20/23	EFT	003479 Prudential Retirement Ins 2100-00-0000-22520-000000-000000	1,570.00	1,570.00		

AP CHECK RECONCILIATION REGISTER

FOR CASH ACCOUNT: 9999-00-0000-10110-000000-000000

FOR: All Except Stale

CHECK #	CHECK DATE	TYPE	VENDOR NAME	UNCLEARED	CLEARED	BATCH	CLEAR DATE
400620	10/20/2023	EFT	003475 Red Barn Kennels LLC	114.00			
			INVOICE NO	ACCOUNT	AMOUNT		
			09/30/23-10/02/23	2090-PD-PD00-53190-000000-	114.00		
400621	10/20/2023	EFT	004124 Richard F. Castle	1,006.25			
			001	2070-PI-PI00-53190-000000-		1,006.25	
400622	10/20/2023	EFT	000505 Rumpke of Ohio Inc.	402.62			
			3921730	1010-PK-PK00-54550-000000-		120.00	
			0342478	2100-FD-FD00-55060-000000-		74.25	
			0373372	2100-FD-FD00-55060-000000-		68.27	
			0341498	2100-FD-FD00-55060-000000-		74.09	
			0245382	2100-FD-FD00-55060-000000-		66.01	
400623	10/20/2023	EFT	003323 Shrader Tire & Oil, Inc.	268.00			
			23-0802874-00	2010-RD-RD00-53510-000000-		268.00	
400624	10/20/2023	EFT	000800 Signs By Tomorrow	328.59			
			22592	2070-PI-PI00-56030-PUMPKN-		246.35	
			22592A	2070-PI-PI00-53710-000000-		82.24	
400625	10/20/2023	EFT	003228 Smyrna Ready Mix Concrete	908.00			
			1020427160	2010-RD-RD00-54550-IHCLVT-		432.00	
			1020427601	2010-RD-RD00-54550-IHCLVT-		476.00	
400626	10/20/2023	EFT	003938 Strategic Ohio Council Fo	708.12			
			13590	1010-PK-PK00-53190-000000-		354.06	
			13590	2040-RD-RD00-53190-000000-		354.06	
400627	10/20/2023	EFT	000539 Sycamore Auto Repair	1,265.03			
			Car 1888 Repair Hood	2090-PD-PD00-53510-000000-		1,265.03	
400628	10/20/2023	EFT	003948 Titan Trophies & Apparel	250.00			
			1401	2100-FD-FD00-53190-000000-		250.00	
400629	10/20/2023	EFT	003909 City of Trenton	1,007.50			
			10/14/23 A	2090-PD-PD00-51120-000000-		195.00	
			10/14/23 B	2090-PD-PD00-51120-000000-		260.00	
			10/14/23 C	2090-PD-PD00-51120-000000-		552.50	
400630	10/20/2023	EFT	003219 Tri-State Public Safety	1,048.00			
			3462	2090-PD-PD00-53510-000000-		1,048.00	
400631	10/20/2023	EFT	003189 outdoor Home Services Ho	391.29			
			184066805	2100-FD-FD00-53530-000000-		58.57	
			184173560	5080-RD-RD00-54550-000000-		221.18	
			184173675	5080-RD-RD00-54550-000000-		111.54	
400632	10/20/2023	EFT	000573 Valley Asphalt Corporatio	128.25			

AP CHECK RECONCILIATION REGISTER

FOR CASH ACCOUNT: 9999-00-0000-10110-000000-000000

FOR: All Except Stale

CHECK #	CHECK DATE	TYPE	VENDOR NAME	UNCLEARED	CLEARED	BATCH	CLEAR DATE
118938			2010-RD-RD00-54550-IHPAVE-		128.25		
400633	10/20/2023	EFT	001361 Virginia Air Distributors	1,793.87			
			INVOICE NO		AMOUNT		
			42186909-00		1,793.87		
			ACCOUNT				
			1010-AD-AD00-53530-000000-				
400634	10/20/2023	EFT	000583 Vogelpohl Fire Equipment,	535.94			
	4008373		2100-FD-FD00-54720-000000-		535.94		
400635	10/20/2023	EFT	003307 Municipal Emergency Servi	2,109.80			
	IN1909889		2100-FD-FD00-54550-000000-		2,109.80		
			142 CHECKS	CASH ACCOUNT TOTAL	264,397.35		3,309.18

AP CHECK RECONCILIATION REGISTER

		UNCLEARED	CLEARED
142 CHECKS	FINAL TOTAL	264,397.35	3,309.18

** END OF REPORT - Generated by Felicia Krutka **

AP CHECK RECONCILIATION REGISTER

FOR CASH ACCOUNT: 9999-00-0000-10110-000000-000000

FOR: All Except Stale

CHECK #	CHECK DATE	TYPE	VENDOR NAME	UNCLEARED	CLEARED	BATCH	CLEAR DATE
1263	10/27/2023	MANUAL	000780 Lowes	103.87			
	INVOICE NO		ACCOUNT		AMOUNT		
	901100		2010-RD-RD01-54550-000000-		103.87		
1264	10/27/2023	MANUAL	000780 Lowes	120.64			
	901750		2100-FD-FD00-54550-000000-		120.64		
167451	10/23/2023	PRINTED	001551 Brewpro	475.00			
	126054		2010-RD-RD00-54550-IHPAVE-		475.00		
167452	10/27/2023	PRINTED	000615 Altafiber	355.14			
	755-3764 Nov 23		2090-PD-PD00-55010-000000-		177.57		
	755-3764 Nov 23		2100-FD-FD00-55010-000000-		177.57		
167453	10/27/2023	PRINTED	004176 Andrew Moos	124.76			
	Moos 10/14/23		2090-PD-PD00-53410-000000-		124.76		
167454	10/27/2023	PRINTED	004008 Butler County Water & Sew	277.13			
	2060099 Oct 23		1010-PK-PK03-55030-000000-		277.13		
167455	10/27/2023	PRINTED	004072 Courtney Lovell	1,159.90			
	Lovell, C 10/17/23		2250-PD-PD00-53410-000000-		1,159.90		
167456	10/27/2023	PRINTED	001334 Duke Energy	13,204.74			
	910117632260 Oct 23		2100-FD-FD00-55040-000000-		1,166.25		
	910118689401 Oct 23		1010-PK-PK04-55040-000000-		21.85		
	910127970038 Oct 23		1010-PK-PK14-55040-000000-		41.31		
	910119040434 Oct 23		2100-FD-FD00-55040-000000-		1,206.02		
	910117891655 Oct 23		1010-AD-AD00-55040-000000-		2,542.97		
	910117891655 Oct 23		2070-PI-PI00-55040-000000-		346.77		
	910117891887 Oct 23		1010-AD-AD00-55040-000000-		13.33		
	910117891887 Oct 23		1010-CD-CD00-55040-000000-		8.89		
	910117891887 Oct 23		2030-RD-RD00-55040-000000-		97.76		
	910117891887 Oct 23		2090-PD-PD00-55040-000000-		324.39		
	910117892599 Oct 23		1010-PK-PK03-55040-000000-		29.06		
	910117893326 Oct 23		1010-PK-PK11-55040-000000-		626.04		
	910117893417 Oct 23		1010-LT-LT00-55040-000000-		24.00		
	910119396140 Oct 23		2100-FD-FD00-55040-000000-		1,096.34		
	910117632301 Oct 23		2100-FD-FD00-55040-000000-		1,243.73		
	910117892010 Oct 23		1010-PK-PK03-55040-000000-		165.22		
	910119395751 Oct 23		1010-PK-PK12-55040-000000-		1,545.10		
	910119396190 Oct 23		2050-CE-CE00-55040-000000-		132.47		
	910119396231 Oct 23		1010-AD-AD00-55040-000000-		80.87		
	910119396231 Oct 23		2050-CE-CE00-55040-000000-		26.82		
	910119396231 Oct 23		2070-PI-PI00-55040-000000-		10.48		
	910119396231 Oct 23		2090-DS-DS00-55040-000000-		36.87		
	910119396231 Oct 23		2100-DS-DS00-55040-000000-		36.87		
	910119396231 Oct 23		2100-FD-FD00-55040-000000-		2,279.07		
	910119661924 Oct 23		2050-CE-CE00-55040-000000-		16.97		
	910117892440 Oct 23		1010-AD-AD00-55040-000000-		85.29		

AP CHECK RECONCILIATION REGISTER

FOR CASH ACCOUNT: 9999-00-0000-10110-000000-000000

FOR: All Except Stale

CHECK #	CHECK DATE	TYPE	VENDOR NAME	UNCLEARED	CLEARED	BATCH	CLEAR DATE
167457	10/27/2023	PRINTED	004024 Duke Energy	54.65			
			INVOICE NO ACCOUNT AMOUNT				
			910117892549 Nov 23 5070-LT-LT28-55040-000000-		.10		
			910117891837 Nov 23 5070-LT-LT28-55040-000000-		54.55		
167458	10/27/2023	PRINTED	004171 Dwayne W. Ridenour	800.00			
			800.00 2070-PI-PI00-56030-PUMPKN-		800.00		
167459	10/27/2023	PRINTED	000353 John Dsuban Spring Servic	1,201.02			
			0156380-IN 2010-RD-RD00-53510-000000-		1,201.02		
167460	10/27/2023	PRINTED	004178 John Sams	46.25			
			Sams 10/23/23 2010-RD-RD00-53170-000000-		46.25		
167461	10/27/2023	PRINTED	004174 Judith A. Everly	1,021.07			
			8048 Pleasure Dr 2040-RD-RD00-57070-RCURBS-		1,021.07		
167462	10/27/2023	PRINTED	004050 Kellie Byrd	144.10			
			Byrd 10/17/23 A 2740-00-0000-53190-000000-		115.27		
			Byrd 10/17/23 B 1010-AD-AD00-56080-000000-		28.83		
167463	10/27/2023	PRINTED	004051 Larry Burks	2,205.33			
			Burks 10/19/23 1010-AD-AD00-53410-000000-		2,195.33		
			Burks 10/19/23 A 1010-AD-AD00-56080-000000-		10.00		
167464	10/27/2023	PRINTED	002776 Mike Castrucci Ford Inc	426.42			
			142546 2090-PD-PD00-53510-000000-		77.88		
			142590 2090-PD-PD00-53510-000000-		348.54		
167465	10/27/2023	PRINTED	000464 Ohio Department of Job &	149.80			
			46694070 1010-AD-AD00-52250-000000-		149.80		
167466	10/27/2023	PRINTED	002069 Peru's Tree Service	1,700.00			
			0000145 2010-RD-RD00-53190-000000-		1,700.00		
167467	10/27/2023	PRINTED	000482 Pinecrest Nursery	528.00			
			3832 1010-PK-PK03-53530-000000-		257.51		
			3832 1010-PK-PK04-53530-000000-		270.49		
167468	10/27/2023	PRINTED	004061 Stephen Getter	214.40			
			Getter 10/02/23 2100-FD-FD00-53410-000000-		214.40		
167469	10/27/2023	PRINTED	004173 Steven Chad McQueen	91.40			
			McQueen 10/19/23 2010-RD-RD00-53170-000000-		91.40		
167470	10/27/2023	VOID	004045 Township Employees	.00			
			Moos 10/14/23 A 2090-PD-PD00-53410-000000-		63.45		
167471	10/27/2023	PRINTED	004012 Treasurer of State of Ohi	56.52			

AP CHECK RECONCILIATION REGISTER

FOR CASH ACCOUNT: 9999-00-0000-10110-000000-000000

FOR: All Except Stale

CHECK #	CHECK DATE	TYPE	VENDOR NAME	UNCLEARED	CLEARED	BATCH	CLEAR DATE
	HJL6247		1010-AD-AD00-53190-000000-		56.52		
167472	10/27/2023	PRINTED	001091 Vogt Lawn Care	12,625.00			
	INVOICE NO		ACCOUNT		AMOUNT		
	12120		1010-CD-CD00-53210-000000-		12,275.00		
	12121		1010-CD-CD00-53210-000000-		350.00		
400636	10/23/2023	EFT	002035 A1-Joe's Inc	104.28			
	999882		1010-PK-PK00-53560-000000-		104.28		
400637	10/23/2023	EFT	000148 Finn All Seasons	76.00			
	303760		2010-RD-RD00-54550-IHCLVT-		76.00		
400638	10/23/2023	EFT	004151 Fuller Ford Inc	67,959.00			
	46052		2100-FD-FD00-57060-000000-		67,959.00		
400639	10/23/2023	EFT	002655 Kimball Midwest	576.69			
	101552418		2010-RD-RD00-53510-000000-		152.53		
	101552418		2090-PD-PD00-53510-000000-		152.52		
	101552418		2100-FD-FD00-53510-000000-		76.28		
	101552418		2110-EM-EM00-53510-000000-		76.28		
	101552452		2010-RD-RD00-53510-000000-		119.08		
400640	10/23/2023	EFT	003478 O'Reilly Auto Enterprises	1,209.10			
	1738-302922		2010-RD-RD00-53510-000000-		271.02		
	1738-302615		2010-RD-RD00-53560-000000-		938.08		
400641	10/23/2023	EFT	000525 Smith Trailer & Equipment	20.00			
	31098		1010-PK-PK00-53560-000000-		20.00		
400642	10/27/2023	EFT	001532 A-Plus Concrete & Excavat	510.00			
	11021		2070-PI-PI00-56030-PUMPKN-		270.00		
	11027		2070-PI-PI00-56030-PUMPKN-		180.00		
	11049		2010-RD-RD00-54550-IHCLVT-		60.00		
400643	10/27/2023	EFT	003800 ADW Acquisitions LLC	862.80			
	18180746		2090-PD-PD00-53510-000000-		862.80		
400644	10/27/2023	EFT	002469 Aflac Group Insurance	1,258.54			
	WCTWP-9325	Oct 2023	1010-00-0000-22250-000000-000000		110.59		
	WCTWP-9325	Oct 2023	1010-00-0000-22260-000000-000000		98.15		
	WCTWP-9325	Oct 2023	2090-00-0000-22250-000000-000000		166.09		
	WCTWP-9325	Oct 2023	2090-00-0000-22260-000000-000000		204.21		
	WCTWP-9325	Oct 2023	2100-00-0000-22250-000000-000000		314.89		
	WCTWP-9325	Oct 2023	2100-00-0000-22260-000000-000000		297.98		
	WCTWP-9325	Oct 2023	2040-00-0000-22250-000000-000000		32.86		
	WCTWP-9325	Oct 2023	2040-00-0000-22260-000000-000000		16.74		
	WCTWP-9325	Oct 2023	2070-00-0000-22250-000000-000000		17.03		
400645	10/27/2023	EFT	002035 A1-Joe's Inc	73.39			

AP CHECK RECONCILIATION REGISTER

FOR CASH ACCOUNT: 9999-00-0000-10110-000000-000000

FOR: All Except Stale

CHECK #	CHECK DATE	TYPE	VENDOR NAME	UNCLEARED	CLEARED	BATCH	CLEAR DATE
	1000250		2050-CE-CE00-53560-000000-		11.40		
	INVOICE NO		ACCOUNT	AMOUNT			
	1000250		2050-CE-CE00-54550-000000-		61.99		
400646	10/27/2023	EFT	003174 Amazon Fullfillment Servi	548.15			
	1LM6-9VY7-4XJR		2090-PD-PD00-54550-000000-		130.00		
	1VH6-PLHN-96RD		2050-CE-CE00-54010-000000-		177.00		
	1KLX-7MHF-9YRJ		1010-CD-CD00-54010-000000-		148.56		
	134W-XFXC-WQTJ		1010-AD-AD00-54510-000000-		36.37		
	1H9G-6LLV-31Y6		2740-00-0000-53190-000000-		56.22		
400647	10/27/2023	EFT	000192 Ohio Newspapers Inc	471.96			
	I00809151		1010-CD-CD00-53720-000000-		123.12		
	I00808732		1010-CD-CD00-53720-000000-		184.68		
	I00809577-10012023		1010-AD-AD00-53720-000000-		164.16		
400648	10/27/2023	EFT	004116 CT Consultants Inc	2,856.75			
	231700-1		2190-00-0000-57040-NPOINT-		2,856.75		
400649	10/27/2023	EFT	003239 Delta Dental	18,398.84			
	CNS0001385143		1010-00-0000-22230-000000-000000		441.28		
	CNS0001385143		2040-00-0000-22230-000000-000000		228.33		
	CNS0001385143		2050-00-0000-22230-000000-000000		35.59		
	CNS0001385143		2070-00-0000-22230-000000-000000		48.59		
	CNS0001385143		2090-00-0000-22230-000000-000000		1,454.96		
	CNS0001385143		2100-00-0000-22230-000000-000000		1,315.49		
	CNS0001385143		2110-00-0000-22230-000000-000000		114.29		
	CNS0001385143		5080-00-0000-22230-000000-000000		6.50		
	CNS0001385143		2100-00-0000-22240-000000-000000		64.96		
	CNS0001385143		1010-AD-AD00-52230-000000-		996.12		
	CNS0001385143		1010-AD-AD02-52230-000000-		196.10		
	CNS0001385143		1010-AD-AD03-52230-000000-		53.75		
	CNS0001385143		1010-CD-CD00-52230-000000-		353.77		
	CNS0001385143		1010-PK-PK00-52230-000000-		53.75		
	CNS0001385143		1010-SV-SV00-52230-000000-		222.08		
	CNS0001385143		2040-RD-RD00-52230-000000-		913.07		
	CNS0001385143		2050-CE-CE00-52230-000000-		142.35		
	CNS0001385143		2070-PI-PI00-52230-000000-		194.31		
	CNS0001385143		2090-PD-PD00-52230-000000-		5,270.86		
	CNS0001385143		2100-FD-FD00-52230-000000-		4,966.10		
	CNS0001385143		2090-DS-DS00-52230-000000-		548.23		
	CNS0001385143		2100-DS-DS00-52230-000000-		295.21		
	CNS0001385143		2110-EM-EM00-52230-000000-		457.17		
	CNS0001385143		5080-RD-RD00-52230-000000-		25.98		
400650	10/27/2023	EFT	002936 Document Destruction	185.50			
	176735		1010-AD-AD00-53190-000000-		148.03		
	176735		2090-DS-DS00-53190-000000-		9.55		
	176735		2100-DS-DS00-53190-000000-		9.55		
	176735		2100-FD-FD00-53190-000000-		18.37		

AP CHECK RECONCILIATION REGISTER

FOR CASH ACCOUNT: 9999-00-0000-10110-000000-000000

FOR: All Except Stale

CHECK #	CHECK DATE	TYPE	VENDOR NAME	UNCLEARED	CLEARED	BATCH	CLEAR DATE
400651	10/27/2023	EFT	000634 Emcor Facilities Services	43,140.87			
			INVOICE NO	ACCOUNT	AMOUNT		
			607585A	1010-AD-AD00-53530-000000-	5,219.20		
			607585A	2070-PI-PI00-53530-000000-	711.71		
			607586	1010-AD-AD00-53530-000000-	2,395.39		
			607586	2090-DS-DS00-53530-000000-	1,197.69		
			607586	2100-DS-DS00-53530-000000-	1,197.69		
			607588A	1010-PK-PK03-53530-000000-	339.34		
			607588A	1010-PK-PK04-53530-000000-	72.43		
			607588A	1010-PK-PK11-53530-000000-	903.33		
			607588A	1010-PK-PK12-53530-000000-	59.32		
			607589	2050-CE-CE00-53530-000000-	822.22		
			607588B	1010-PK-PK11-53530-000000-	2,500.00		
			607584	1010-AD-AD00-53530-000000-	2,929.64		
			607584	1010-CD-CD00-53530-000000-	2,441.36		
			607584	2010-RD-RD00-53530-000000-	4,150.32		
			607584	2090-PD-PD00-53530-000000-	14,892.33		
			607590D	1010-AD-AD00-53530-000000-	297.07		
			607590D	1010-CD-CD00-53530-000000-	247.56		
			607590D	2010-RD-RD00-53530-000000-	420.85		
			607590D	2090-PD-PD00-53530-000000-	1,510.09		
			607590B	1010-CD-CD00-53530-000000-	444.44		
			607590A	1010-CD-CD00-53530-000000-	388.89		
400652	10/27/2023	EFT	000250 Extermital Termite & Pest	969.15			
			903249	2100-FD-FD00-55060-000000-	90.00		
			903274	2100-FD-FD00-55060-000000-	45.00		
			903277	2100-FD-FD00-55060-000000-	30.00		
			903437	2100-FD-FD00-55060-000000-	30.00		
			904908	2100-FD-FD00-55060-000000-	90.00		
			904962	2100-FD-FD00-55060-000000-	35.00		
			904932	2100-FD-FD00-55060-000000-	45.00		
			904934	2100-FD-FD00-55060-000000-	30.00		
			906042	2100-FD-FD00-55060-000000-	45.00		
			917555	2100-FD-FD00-55060-000000-	90.00		
			917621	2100-FD-FD00-55060-000000-	35.00		
			917585	2100-FD-FD00-55060-000000-	45.00		
			917587	2100-FD-FD00-55060-000000-	30.00		
			917774	2100-FD-FD00-55060-000000-	30.00		
			918606	2100-FD-FD00-55060-000000-	45.00		
			919410	2100-FD-FD00-55060-000000-	90.00		
			914485	2100-FD-FD00-55060-000000-	35.00		
			919439	2100-FD-FD00-55060-000000-	45.00		
			919442	2100-FD-FD00-55060-000000-	30.00		
			919631	2100-FD-FD00-55060-000000-	30.00		
			937932	1010-PK-PK04-53530-000000-	24.15		
400653	10/27/2023	EFT	000273 Frost Brown Todd LLC	45,483.10			
			210399177	2090-PD-PD00-53110-000000-	5,571.00		

AP CHECK RECONCILIATION REGISTER

FOR CASH ACCOUNT: 9999-00-0000-10110-000000-000000

FOR: All Except Stale

CHECK #	CHECK DATE	TYPE	VENDOR NAME	UNCLEARED	CLEARED	BATCH	CLEAR DATE
	210398943		1010-AD-AD00-53110-000000-		34,317.10		
	INVOICE NO		ACCOUNT		AMOUNT		
	210398943		2010-RD-RD00-53110-000000-		264.00		
	210398943		2090-PD-PD00-53110-000000-		3,300.00		
	210398943		2100-FD-FD00-53110-000000-		1,866.00		
	210398943		2180-00-0000-53110-000000-		165.00		
400654	10/27/2023	EFT	000277 Galls, LLC	4,454.12			
	BC1976891		2090-PD-PD00-54720-000000-		81.48		
	BC1978740		2090-PD-PD00-54720-BPVEST-		4,372.64		
400655	10/27/2023	EFT	000929 Institute of Police Techn	895.00			
	Crash Recon 11/13/23		2250-PD-PD00-53410-000000-		895.00		
400656	10/27/2023	EFT	002655 Kimball Midwest	100.30			
	101565074		2010-RD-RD00-53510-000000-		100.30		
400657	10/27/2023	EFT	000373 Kleem Inc.	287.50			
	98702		2010-RD-RD00-54550-000000-		287.50		
400658	10/27/2023	EFT	000447 Murphy Supply Company	2,661.25			
	210005		1010-AD-AD00-53530-000000-		1,398.00		
	210048		1010-PK-PK00-54550-000000-		955.00		
	210048		2010-RD-RD00-54550-000000-		308.25		
400659	10/27/2023	EFT	000456 Nick's Towing	200.00			
	38599		2090-PD-PD00-53240-000000-		200.00		
400660	10/27/2023	EFT	003478 O'Reilly Auto Enterprises	118.95			
	1738-301016		2090-PD-PD00-53510-000000-		-22.00		
	1738-301016		2090-PD-PD00-53510-000000-		-22.00		
	1738-301016		2090-PD-PD00-53510-000000-		-22.00		
	1738-262629		2100-FD-FD00-53510-000000-		-22.00		
	1738-262629		2100-FD-FD00-53510-000000-		-22.00		
	1738-262629		2100-FD-FD00-53510-000000-		-22.00		
	1738-262629		2100-FD-FD00-53510-000000-		-22.00		
	1738-246248		2110-EM-EM00-53510-000000-		-22.00		
	1738-246248		2110-EM-EM00-53510-000000-		-22.00		
	1738-246248		2110-EM-EM00-53510-000000-		-22.00		
	1738-246248		2110-EM-EM00-53510-000000-		-22.00		
	1738-303853		2010-RD-RD00-53510-000000-		85.03		
	1738-303792		2010-RD-RD00-53510-000000-		114.17		
	1738-304061		2090-PD-PD00-53510-000000-		253.92		
	1738-304081		2010-RD-RD00-53510-000000-		-114.17		
400661	10/27/2023	EFT	000505 Rumpke of Ohio Inc.	150.00			
	3922614		1010-SV-SV00-53550-000000-		150.00		
400662	10/27/2023	EFT	000761 Staples Inc	90.01			
	3550025272		2010-RD-RD00-54510-000000-		43.23		
	3550025223		1010-AD-AD00-54510-000000-		46.78		

AP CHECK RECONCILIATION REGISTER

FOR CASH ACCOUNT: 9999-00-0000-10110-000000-000000

FOR: All Except Stale

CHECK #	CHECK DATE	TYPE	VENDOR NAME	UNCLEARED	CLEARED	BATCH	CLEAR DATE
400663	10/27/2023	EFT	000539 Sycamore Auto Repair	500.00			
		INVOICE NO	ACCOUNT		AMOUNT		
		estimate - 6d04bb7e	2090-PD-PD00-53510-000000-		500.00		
400664	10/27/2023	EFT	001034 W.G. Stang, LLC	191,318.67			
		Pay Request 4	2190-00-0000-57040-000000-		191,318.67		
		53 CHECKS	CASH ACCOUNT TOTAL	422,565.06	.00		

AP CHECK RECONCILIATION REGISTER

		UNCLEARED	CLEARED
53 CHECKS	FINAL TOTAL	422,565.06	.00

** END OF REPORT - Generated by Felicia Krutka **

AP CHECK RECONCILIATION REGISTER

FOR CASH ACCOUNT: 9999-00-0000-10110-000000-000000

FOR: All Except Stale

CHECK #	CHECK DATE	TYPE	VENDOR NAME	UNCLEARED	CLEARED	BATCH	CLEAR DATE
1265	11/01/2023	MANUAL	002837 First Financial Bank Cred	23.12			
	INVOICE NO		ACCOUNT		AMOUNT		
	FedEx 9/28/23		2010-RD-RD00-53730-000000-		23.12		
1266	11/01/2023	MANUAL	002837 First Financial Bank Cred	71.98			
	Batteries 10/11/23		2010-RD-RD00-53560-000000-		71.98		
1267	11/01/2023	MANUAL	002837 First Financial Bank Cred	13.13			
	Michaels 10/17/23		1010-PK-PK10-56030-NTRBSK-		13.13		
1268	11/01/2023	MANUAL	002837 First Financial Bank Cred	1,004.96			
	Solar 10/19/23		1010-AD-AD00-53530-000000-		1,004.96		
1269	11/01/2023	MANUAL	002837 First Financial Bank Cred	-11.91			
	Michaels 10/25/23		1010-PK-PK10-56030-NTRBSK-		-11.91		
1270	11/03/2023	MANUAL	002837 First Financial Bank Cred	139.20			
	Chipotle 10/3/23		1010-SV-SV00-54530-000000-		139.20		
1271	11/03/2023	MANUAL	002837 First Financial Bank Cred	17.98			
	walmart 10/5/23		1010-SV-SV00-54530-000000-		17.98		
1272	11/03/2023	MANUAL	002837 First Financial Bank Cred	19.20			
	WM SuperCtr 10/16/23		2010-RD-RD00-54530-000000-		19.20		
1273	11/03/2023	MANUAL	002837 First Financial Bank Cred	66.00			
	USPS 10/16/23		2070-PI-PI00-56030-RASKAL-		66.00		
1274	11/03/2023	MANUAL	002837 First Financial Bank Cred	238.00			
	PODS 10/17/23		2190-00-0000-57010-000000-		238.00		
1275	11/03/2023	MANUAL	002837 First Financial Bank Cred	17.19			
	UPS 10/26/23		2010-RD-RD00-53730-000000-		17.19		
1276	11/03/2023	MANUAL	002837 First Financial Bank Cred	169.60			
	Panera 10/3/23		1010-CD-CD00-54530-000000-		169.60		
1277	11/03/2023	MANUAL	002837 First Financial Bank Cred	12.15			
	AuthorizeNet 10/3/23		1010-CD-CD00-53180-000000-		12.15		
1278	11/03/2023	MANUAL	002837 First Financial Bank Cred	10.00			
	GoToCom 10/21/23		1010-CD-CD00-55020-000000-		10.00		
1279	11/03/2023	MANUAL	002837 First Financial Bank Cred	87.82			
	WM SuperCtr 10/23/23		1010-CD-CD00-54540-000000-		87.82		
1280	11/03/2023	MANUAL	002837 First Financial Bank Cred	828.40			
	graduate 9/29/23		2100-FD-FD00-53410-000000-		828.40		
1281	11/03/2023	MANUAL	002837 First Financial Bank Cred	2.29			

AP CHECK RECONCILIATION REGISTER

FOR CASH ACCOUNT: 9999-00-0000-10110-000000-000000

FOR: All Except Stale

CHECK #	CHECK DATE	TYPE	VENDOR NAME	UNCLEARED	CLEARED	BATCH	CLEAR DATE
	8 sisters 10/10/23		1010-AD-AD00-53410-000000-		2.29		
1282	11/03/2023	MANUAL	002837 First Financial Bank Cred	13.59			
	INVOICE NO		ACCOUNT		AMOUNT		
	Daves 10/10/23		1010-AD-AD00-53410-000000-		13.59		
1283	11/03/2023	MANUAL	002837 First Financial Bank Cred	778.11			
	Hilton 10/13/23		1010-AD-AD00-53410-000000-		778.11		
1284	11/03/2023	MANUAL	002837 First Financial Bank Cred	19.97			
	5Guys 10/13/23		1010-AD-AD00-53410-000000-		19.97		
167473	11/03/2023	PRINTED	004047 Adam Inskeep	39.04			
	Inskeep 10/30/23		2070-PI-PI00-56050-000000-		28.17		
	Inskeep 10/30/23		2070-PI-PI00-56080-000000-		10.87		
167474	11/03/2023	PRINTED	003776 Advanced Underground Inc	4,200.00			
	4484		1010-AD-AD00-57010-000000-		4,200.00		
167475	11/03/2023	PRINTED	000615 Altafiber	1,649.25			
	755-7700 Nov 23		2100-FD-FD00-55010-000000-		101.48		
	942-6275 Nov 23		1010-AD-AD00-55010-000000-		2.97		
	942-6275 Nov 23		1010-CD-CD00-55010-000000-		1.98		
	942-6275 Nov 23		2030-RD-RD00-55010-000000-		21.80		
	942-6275 Nov 23		2090-PD-PD00-55010-000000-		72.12		
	103-0375 Nov 23		1010-PK-PK12-55010-000000-		49.99		
	103-0718 Nov 23		1010-PK-PK11-55010-000000-		70.99		
	777-1334 Nov 23		2100-FD-FD00-55010-000000-		253.79		
	777-2303 Nov 23		2100-FD-FD00-55010-000000-		101.59		
	874-1960 Nov 23		2090-PD-PD00-55010-000000-		44.48		
	874-6805 Nov 23		1010-AD-AD00-55010-000000-		1.52		
	874-6805 Nov 23		1010-CD-CD00-55010-000000-		1.01		
	874-6805 Nov 23		2030-RD-RD00-55010-000000-		11.14		
	874-6805 Nov 23		2090-PD-PD00-55010-000000-		36.20		
	874-6958 Nov 23		1010-AD-AD00-55010-000000-		1.33		
	874-6958 Nov 23		1010-CD-CD00-55010-000000-		.89		
	874-6958 Nov 23		2030-RD-RD00-55010-000000-		9.80		
	874-6958 Nov 23		2090-PD-PD00-55010-000000-		32.46		
	942-4910 Nov 23		1010-AD-AD00-55010-000000-		5.40		
	942-4910 Nov 23		1010-CD-CD00-55010-000000-		3.59		
	942-4910 Nov 23		2030-RD-RD00-55010-000000-		39.55		
	942-4910 Nov 23		2090-PD-PD00-55010-000000-		127.94		
	777-2231 Nov 23		1010-AD-AD00-55010-000000-		79.69		
	777-2231 Nov 23		1010-CD-CD00-55010-000000-		79.68		
	777-2231 Nov 23		1010-PK-PK00-55010-000000-		39.84		
	777-2231 Nov 23		1010-SV-SV00-55010-000000-		33.20		
	777-2231 Nov 23		2030-RD-RD00-55010-000000-		33.20		
	777-2231 Nov 23		2090-PD-PD00-55010-000000-		262.38		
	777-2231 Nov 23		2100-FD-FD00-55010-000000-		129.24		

AP CHECK RECONCILIATION REGISTER

FOR CASH ACCOUNT: 9999-00-0000-10110-000000-000000

FOR: All Except Stale

CHECK #	CHECK DATE	TYPE	VENDOR NAME	UNCLEARED	CLEARED	BATCH	CLEAR DATE
167476	11/03/2023	PRINTED	004176 Andrew Moos	63.45			
	INVOICE NO		ACCOUNT		AMOUNT		
	Moos 10/14/23 A		2090-PD-PD00-53410-000000-		63.45		
167477	11/03/2023	PRINTED	004087 Beverly Worley	32.75			
	Worley 10/24/23		1010-CD-CD00-56080-000000-		32.75		
167478	11/03/2023	PRINTED	004004 Butler County Prosecutor' Case 23-2798 (104)	770.00			
			2620-PD-PD00-43540-BCPROS-		770.00		
167479	11/03/2023	PRINTED	004042 Butler Tech & Career Dev	152,273.50			
	10/02/23		2190-00-0000-56070-000000-		87,963.38		
	10/02/23		2170-00-0000-56070-000000-		34,127.86		
	10/02/23		2160-00-0000-56070-000000-		2,396.77		
	10/02/23		2150-00-0000-56070-000000-		21,626.54		
	10/02/23		2140-00-0000-56070-000000-		4,051.06		
	10/02/23		2130-00-0000-56070-000000-		2,107.89		
167480	11/03/2023	PRINTED	004009 Cincinnati Bell Any Dista	47.89			
	2323805-10202023		1010-AD-AD00-55010-000000-		5.74		
	2323805-10202023		1010-CD-CD00-55010-000000-		5.75		
	2323805-10202023		1010-PK-PK00-55010-000000-		2.87		
	2323805-10202023		1010-SV-SV00-55010-000000-		2.40		
	2323805-10202023		2030-RD-RD00-55010-000000-		2.40		
	2323805-10202023		2090-PD-PD00-55010-000000-		19.16		
	2323805-10202023		2100-FD-FD00-55010-000000-		9.57		
167481	11/03/2023	PRINTED	001334 Duke Energy	15,253.63			
	910117893003 Oct 23		1010-AD-AD00-55040-000000-		917.44		
	910117893003 Oct 23		2070-PI-PI00-55040-000000-		131.07		
	910117893003 Oct 23		2090-DS-DS00-55040-000000-		411.94		
	910117893003 Oct 23		2100-DS-DS00-55040-000000-		411.95		
	910117893144 Oct 23		1010-PK-PK13-55040-000000-		594.17		
	910117891788 Oct 23		1010-LT-LT00-55040-000000-		487.39		
	910117892953 Oct 23		1010-AD-AD00-55040-000000-		318.25		
	910117892953 Oct 23		1010-CD-CD00-55040-000000-		212.18		
	910117892953 Oct 23		2030-RD-RD00-55040-000000-		2,333.94		
	910117892953 Oct 23		2090-PD-PD00-55040-000000-		7,744.43		
	910117893540 Oct 23		1010-LT-LT00-55040-000000-		1,690.87		
167482	11/03/2023	PRINTED	004024 Duke Energy	22,022.13			
	930000024706 Nov 23		5070-LT-LT21-55040-000000-		186.58		
	910117892169 Nov 23		5070-LT-LT01-55040-000000-		373.99		
	910117891134 Nov 23		5070-LT-LT01-55040-000000-		169.93		
	910117893277 Nov 23		5070-LT-LT02-55040-000000-		743.58		
	910117152342 Nov 23		5070-LT-LT03-55040-000000-		292.94		
	910117152384 Nov 23		5070-LT-LT03-55040-000000-		983.71		
	910117152417 Nov 23		5070-LT-LT03-55040-000000-		717.74		
	910117892218 Nov 23		5070-LT-LT04-55040-000000-		1,367.79		
	910117892911 Nov 23		5070-LT-LT05-55040-000000-		268.60		

AP CHECK RECONCILIATION REGISTER

FOR CASH ACCOUNT: 9999-00-0000-10110-000000-000000

FOR: All Except Stale

CHECK #	CHECK DATE	TYPE	VENDOR NAME	UNCLEARED	CLEARED	BATCH	CLEAR DATE
910117891233	Nov 23		5070-LT-LT06-55040-000000-		1,687.42		
		INVOICE NO	ACCOUNT		AMOUNT		
		910117893590	Nov 23 5070-LT-LT07-55040-000000-		2,377.98		
		910117891366	Nov 23 5070-LT-LT09-55040-000000-		522.93		
		910117893649	Nov 23 5070-LT-LT10-55040-000000-		1,136.44		
		910117891514	Nov 23 5070-LT-LT11-55040-000000-		1,221.70		
		910117891415	Nov 23 5070-LT-LT12-55040-000000-		649.84		
		910117892250	Nov 23 5070-LT-LT12-55040-000000-		353.94		
		910117892630	Nov 23 5070-LT-LT13-55040-000000-		2,232.77		
		910117152459	Nov 23 5070-LT-LT14-55040-000000-		273.30		
		910119396067	Nov 23 5070-LT-LT16-55040-000000-		308.52		
		910117892490	Nov 23 5070-LT-LT17-55040-000000-		2,140.64		
		910119395686	Nov 23 5070-LT-LT19-55040-000000-		275.29		
		910117891564	Nov 23 5070-LT-LT19-55040-000000-		343.90		
		910119395892	Nov 23 5070-LT-LT19-55040-000000-		638.33		
		910117892838	Nov 23 5070-LT-LT19-55040-000000-		260.24		
		910117891960	Nov 23 5070-LT-LT20-55040-000000-		420.86		
		910117892119	Nov 23 5070-LT-LT22-55040-000000-		203.06		
		910117892341	Nov 23 5070-LT-LT24-55040-000000-		192.14		
		910117892721	Nov 23 5070-LT-LT25-55040-000000-		710.49		
		910117801798	Nov 23 5070-LT-LT28-55040-000000-		607.70		
		910119133256	Nov 23 5070-LT-LT29-55040-000000-		359.78		
167483	11/03/2023	PRINTED	004024 Duke Energy	1,628.24			
		910119395975	Nov 23 5070-LT-LT08-55040-000000-		142.32		
		910117891465	Nov 23 5070-LT-LT15-55040-000000-		76.11		
		910119395800	Nov 23 5070-LT-LT16-55040-000000-		112.72		
		910119395933	Nov 23 5070-LT-LT16-55040-000000-		51.54		
		910119396091	Nov 23 5070-LT-LT16-55040-000000-		137.21		
		910119396017	Nov 23 5070-LT-LT19-55040-000000-		57.81		
		910117893053	Nov 23 5070-LT-LT19-55040-000000-		156.52		
		910117891332	Nov 23 5070-LT-LT22-55040-000000-		114.70		
		910117891605	Nov 23 5070-LT-LT22-55040-000000-		34.25		
		910117891704	Nov 23 5070-LT-LT22-55040-000000-		23.70		
		910117891928	Nov 23 5070-LT-LT22-55040-000000-		44.79		
		910117893095	Nov 23 5070-LT-LT22-55040-000000-		55.35		
		910117893491	Nov 23 5070-LT-LT22-55040-000000-		44.79		
		910117892789	Nov 23 5070-LT-LT22-55040-000000-		33.01		
		910117891085	Nov 23 5070-LT-LT23-55040-000000-		55.26		
		910117892060	Nov 23 5070-LT-LT25-55040-000000-		26.13		
		910118665792	Nov 23 5070-LT-LT25-55040-000000-		38.21		
		910117891283	Nov 23 5070-LT-LT25-55040-000000-		25.55		
		910117893467	Nov 23 5070-LT-LT25-55040-000000-		20.43		
		910117891184	Nov 23 5070-LT-LT25-55040-000000-		47.03		
		910119395727	Nov 23 5070-LT-LT26-55040-000000-		100.47		
		910117892391	Nov 23 5070-LT-LT27-55040-000000-		83.16		
		910118107656	Nov 23 5070-LT-LT27-55040-000000-		20.29		
		910117892888	Nov 23 5070-LT-LT27-55040-000000-		26.69		
		910118404280	Nov 23 5070-LT-LT27-55040-000000-		28.11		
		910117401978	Nov 23 5070-LT-LT27-55040-000000-		72.09		

AP CHECK RECONCILIATION REGISTER

FOR CASH ACCOUNT: 9999-00-0000-10110-000000-000000

FOR: All Except Stale

CHECK #	CHECK DATE	TYPE	VENDOR NAME	UNCLEARED	CLEARED	BATCH	CLEAR DATE
167484	11/03/2023	PRINTED	000585 Grainger Inc.	145.65			
		INVOICE NO	ACCOUNT		AMOUNT		
		9859460678	2100-FD-FD00-53530-000000-		145.65		
167485	11/03/2023	PRINTED	000753 Great American Financial	495.00			
	11/03/23		2090-00-0000-22520-000000-000000		495.00		
167486	11/03/2023	PRINTED	002253 Jamie's Mulch And Topsoil	5,819.99			
	A27659		1010-PK-PK14-53530-000000-		219.99		
	A27698		2010-RD-RD00-53530-000000-		2,800.00		
	A72505		2010-RD-RD00-53530-000000-		2,800.00		
167487	11/03/2023	PRINTED	004080 Jason Flick	93.74			
	Flick 10/27/23		2090-PD-PD00-53410-000000-		93.74		
167488	11/03/2023	PRINTED	004049 Jenna Whittaker	32.98			
	Whittaker 10/26/23		1010-AD-AD00-54530-000000-		32.98		
167489	11/03/2023	PRINTED	004075 Jill Vetere	86.53			
	Vetere 09/28/23		2090-PD-PD00-56080-000000-		86.53		
167490	11/03/2023	PRINTED	004046 Justin Eckstein	39.21			
	Eckstein 10/20/23		2070-PI-PI00-56050-000000-		7.86		
	Eckstein 10/20/23		2070-PI-PI00-56080-000000-		31.35		
167491	11/03/2023	PRINTED	004088 Katy Kanelopoulos	221.15			
	Kanelopoulos 10/24/23		1010-CD-CD00-56080-000000-		221.15		
167492	11/03/2023	PRINTED	004182 Kevin Burger	78.58			
	Burger 10/24/23		2090-PD-PD00-53410-000000-		78.58		
167493	11/03/2023	PRINTED	003371 Pre-Paid Legal Services,	177.55			
	0156853 Oct 2023		1010-00-0000-22730-000000-000000		90.75		
	0156853 Oct 2023		2090-00-0000-22730-000000-000000		15.56		
	0156853 Oct 2023		2100-00-0000-22730-000000-000000		71.24		
167494	11/03/2023	PRINTED	002967 Michael S. Lyons	168.75			
	04-2023		2070-PI-PI00-53190-000000-		168.75		
167495	11/03/2023	PRINTED	004097 Marilyn McHale	117.90			
	McHale 10/12/23		1010-CD-CD00-56080-000000-		117.90		
167496	11/03/2023	PRINTED	001000 Ohio GFOA	70.00			
	12789		1010-AD-AD00-53170-000000-		70.00		
167497	11/03/2023	PRINTED	000755 Ohio Public Employees Def	26,604.20			
	Oh Dfrd 11/03/23		1010-00-0000-22520-000000-000000		4,245.00		
	Oh Dfrd 11/03/23		2090-00-0000-22520-000000-000000		13,433.52		
	Oh Dfrd 11/03/23		2100-00-0000-22520-000000-000000		6,720.68		

AP CHECK RECONCILIATION REGISTER

FOR CASH ACCOUNT: 9999-00-0000-10110-000000-000000

FOR: All Except Stale

CHECK #	CHECK DATE	TYPE	VENDOR NAME	UNCLEARED	CLEARED	BATCH	CLEAR DATE
	oh Dfrd 11/03/23		2110-00-0000-22520-000000-000000		200.00		
	INVOICE NO		ACCOUNT		AMOUNT		
	oh Dfrd 11/03/23		2040-00-0000-22520-000000-000000		1,710.00		
	oh Dfrd 11/03/23		2070-00-0000-22520-000000-000000		295.00		
167498	11/03/2023	PRINTED	004161 Raymond Jones Jones 10/24/23	167.96	167.96		
167499	11/03/2023	PRINTED	001329 Security Benefit Group	8,495.00			
	611021 11/03/23		2090-00-0000-22520-000000-000000		1,913.75		
	611021 11/03/23		2100-00-0000-22520-000000-000000		5,443.75		
	611021 11/03/23		2110-00-0000-22520-000000-000000		693.75		
	611021 11/03/23		2040-00-0000-22520-000000-000000		243.75		
	611021 11/03/23		5080-00-0000-22520-000000-000000		200.00		
167500	11/03/2023	PRINTED	003777 Olga Onipko 39816	20.00	20.00		
167501	11/03/2023	PRINTED	004085 Tim Dawson Dawson 10/24/23	98.91	98.91		
167502	11/03/2023	PRINTED	004010 Treasurer of State of Ohi 24L1386	600.00	600.00		
167503	11/03/2023	PRINTED	003759 Unifirst Corporation	547.76			
	1340221784		1010-PK-PK00-54550-000000-		33.02		
	1340221784		1010-PK-PK00-54720-000000-		22.04		
	1340221784		1010-SV-SV00-54720-000000-		24.59		
	1340221784		2010-RD-RD00-54550-000000-		16.16		
	1340221784		2010-RD-RD00-54720-000000-		164.35		
	1340221784		2050-CE-CE00-54720-000000-		14.45		
	1340225027		1010-PK-PK00-54550-000000-		33.02		
	1340225027		1010-PK-PK00-54720-000000-		22.04		
	1340225027		1010-SV-SV00-54720-000000-		24.59		
	1340225027		2010-RD-RD00-54550-000000-		16.16		
	1340225027		2010-RD-RD00-54720-000000-		162.89		
	1340225027		2050-CE-CE00-54720-000000-		14.45		
167504	11/03/2023	PRINTED	004017 U.S. Bank National Associ	1,680.50			
	514181445		1010-AD-AD00-53550-000000-		272.52		
	514181445		1010-CD-CD00-53550-000000-		181.68		
	514181445		1010-AD-HR00-53550-000000-		90.84		
	514181445		2010-RD-RD00-53550-000000-		90.84		
	514181445		2070-PI-PI00-53550-000000-		90.84		
	514181445		2090-DS-DS00-53550-000000-		45.42		
	514181445		2090-PD-PD00-53550-000000-		363.33		
	514181445		2100-DS-DS00-53550-000000-		45.42		
	514181445		2100-FD-FD00-53550-000000-		499.61		
167505	11/03/2023	PRINTED	000577 Verizon wireless	1,421.64			

AP CHECK RECONCILIATION REGISTER

FOR CASH ACCOUNT: 9999-00-0000-10110-000000-000000

FOR: All Except Stale

CHECK #	CHECK DATE	TYPE	VENDOR NAME	UNCLEARED	CLEARED	BATCH	CLEAR DATE
	9947289989		1010-AD-AD00-55020-000000-		84.56		
	INVOICE NO		ACCOUNT		AMOUNT		
	9947289989		2070-PI-PI00-55020-000000-		40.11		
	9947289989		2090-DS-DS00-55020-000000-		44.39		
	9947289989		2090-PD-PD00-55020-000000-		1,173.25		
	9947289989		2100-DS-DS00-55020-000000-		44.39		
	9947289989		2100-FD-FD00-55020-000000-		94.05		
	9947289989A		1010-CD-CD00-55020-000000-		-28.06		
	9947289989A		1010-SV-SV00-55020-000000-		-31.05		
167506	11/03/2023	PRINTED	004086 Vicki Eldridge	74.67			
	Eldridge 10/06/23		1010-CD-CD00-56080-000000-		74.67		
167507	11/03/2023	PRINTED	000600 Zimmer Tractor	136.88			
	003-3026899		2010-RD-RD00-53560-000000-		136.88		
400665	11/03/2023	EFT	000008 Ace Hardware W.C. Inc.	5.38			
	35450/1		1010-PK-PK00-54550-000000-		5.38		
400666	11/03/2023	EFT	000019 Aetna	405,308.64			
	J1065957		1010-00-0000-22210-000000-000000		6,877.28		
	J1065957		2040-00-0000-22210-000000-000000		4,613.90		
	J1065957		2050-00-0000-22210-000000-000000		716.74		
	J1065957		2070-00-0000-22210-000000-000000		1,022.58		
	J1065957		2090-00-0000-22210-000000-000000		23,595.19		
	J1065957		2100-00-0000-22210-000000-000000		21,385.69		
	J1065957		2110-00-0000-22210-000000-000000		3,173.42		
	J1065957		5080-00-0000-22210-000000-000000		160.70		
	J1065957		2100-00-0000-22240-000000-000000		768.97		
	J1065957		1010-00-0000-22270-000000-000000		262.64		
	J1065957		2040-00-0000-22270-000000-000000		110.18		
	J1065957		2050-00-0000-22270-000000-000000		5.76		
	J1065957		2070-00-0000-22270-000000-000000		39.33		
	J1065957		2090-00-0000-22270-000000-000000		901.91		
	J1065957		2100-00-0000-22270-000000-000000		800.61		
	J1065957		2110-00-0000-22270-000000-000000		86.69		
	J1065957		1010-AD-AD00-52210-000000-		21,738.13		
	J1065957		1010-AD-AD02-52210-000000-		3,300.82		
	J1065957		1010-AD-AD03-52210-000000-		653.63		
	J1065957		1010-CD-CD00-52210-000000-		8,463.14		
	J1065957		1010-PK-PK00-52210-000000-		1,215.75		
	J1065957		1010-SV-SV00-52210-000000-		5,257.88		
	J1065957		2040-RD-RD00-52210-000000-		23,806.99		
	J1065957		2050-CE-CE00-52210-000000-		3,688.57		
	J1065957		2070-PI-PI00-52210-000000-		5,794.84		
	J1065957		2090-PD-PD00-52210-000000-		120,836.26		
	J1065957		2100-FD-FD00-52210-000000-		115,961.79		
	J1065957		2090-DS-DS00-52210-000000-		11,986.19		
	J1065957		2100-DS-DS00-52210-000000-		6,454.11		
	J1065957		2110-EM-EM00-52210-000000-		10,844.33		

AP CHECK RECONCILIATION REGISTER

FOR CASH ACCOUNT: 9999-00-0000-10110-000000-000000

FOR: All Except Stale

CHECK #	CHECK DATE	TYPE	VENDOR NAME	UNCLEARED	CLEARED	BATCH	CLEAR DATE
	J1065957		5080-RD-RD00-52210-000000-		784.62		
400667	11/03/2023	EFT	002422 AFSCME Ohio Council 8, Lo	424.80			
	INVOICE NO		ACCOUNT		AMOUNT		
	11/03/23	Dues	1010-00-0000-22510-000000-000000		53.10		
	11/03/23	Dues	2090-00-0000-22510-000000-000000		13.26		
	11/03/23	Dues	2100-00-0000-22510-000000-000000		13.28		
	11/03/23	Dues	2110-00-0000-22510-000000-000000		13.28		
	11/03/23	Dues	2040-00-0000-22510-000000-000000		278.78		
	11/03/23	Dues	5080-00-0000-22510-000000-000000		26.55		
	11/03/23	Dues	2050-00-0000-22510-000000-000000		26.55		
400668	11/03/2023	EFT	002035 Al-Joe's Inc	329.66			
	1000603		1010-PK-PK00-53560-000000-		140.87		
	1000297		2100-FD-FD00-54010-000000-		188.79		
400669	11/03/2023	EFT	003939 All Star Bronze	3,276.38			
	10/30/2023		2070-PI-PI00-56030-BICNTL-		3,276.38		
400670	11/03/2023	EFT	003347 Robert A. Allen	787.50			
	036		2070-PI-PI00-53190-000000-		787.50		
400671	11/03/2023	EFT	003174 Amazon Fullfillment Servi	287.78			
	1wQv-64NK-1CKH		2100-FD-FD00-53530-000000-		249.00		
	1HW9-VCTD-1LY9		2100-FD-FD00-54550-000000-		38.78		
400672	11/03/2023	EFT	004156 Arc Document Solutions LL	427.32			
	510HI9289185		1010-CD-CD00-53560-000000-		146.37		
	510HI928977		1010-CD-CD00-53560-000000-		280.95		
400673	11/03/2023	EFT	004122 Bachman's Inc	5,450.00			
	J000674		2100-FD-FD00-53560-000000-		5,450.00		
400674	11/03/2023	EFT	002836 Blust Motor Service, Inc.	1,071.31			
	01P11647		2010-RD-RD00-53510-000000-		1,071.31		
400675	11/03/2023	EFT	000123 Bobcat Enterprises Inc.	2,068.26			
	P06076		2010-RD-RD00-53560-000000-		2,068.26		
400676	11/03/2023	EFT	004179 Clarke Power Services Inc	60.54			
	C101115221:01		2010-RD-RD00-53510-000000-		60.54		
400677	11/03/2023	EFT	002614 Great Oaks Career Campuse	4,200.00			
	PUBS-12657		2100-FD-FD00-53410-000000-		4,200.00		
400678	11/03/2023	EFT	003372 Adam Eckstein	787.50			
	30		2070-PI-PI00-53190-000000-		787.50		
400679	11/03/2023	EFT	000634 Emcor Facilities Services	6,760.24			
	607587		2100-FD-FD00-53530-000000-		1,758.26		

AP CHECK RECONCILIATION REGISTER

FOR CASH ACCOUNT: 9999-00-0000-10110-000000-000000

FOR: All Except Stale

CHECK #	CHECK DATE	TYPE	VENDOR NAME	UNCLEARED	CLEARED	BATCH	CLEAR DATE
	43129617		2090-DS-DS00-53530-000000-		2,041.47		
	INVOICE NO		ACCOUNT	AMOUNT			
	43129617		2100-DS-DS00-53530-000000-		2,041.48		
	607585B		1010-AD-AD00-53530-000000-		919.03		
400680	11/03/2023	EFT	003763 The Fechheimer Brothers C	2,289.37			
	000249225 (E)		2700-PD-PD00-54720-000000-		237.36		
	000249225 (D)		2700-PD-PD00-54720-000000-		237.34		
	000249225 (C)		2700-PD-PD00-54720-000000-		237.34		
	000249225 (B)		2700-PD-PD00-54720-000000-		237.34		
	000249225 (A)		2700-PD-PD00-54720-000000-		237.34		
	000251319		2090-PD-PD00-54720-000000-		177.36		
	000251785		2090-PD-PD00-54720-000000-		307.96		
	000248954		2700-PD-PD00-54720-000000-		235.13		
	000252971		2700-PD-PD00-54720-000000-		382.20		
400681	11/03/2023	EFT	000148 Finn All Seasons	213.25			
	303904		2010-RD-RD00-54550-IHCLVT-		213.25		
400682	11/03/2023	EFT	003025 First In-Last Out Fire &	240.00			
	2439		2100-FD-FD00-54550-000000-		240.00		
400683	11/03/2023	EFT	000754 F.O.P. Lodge #186	2,017.50			
	FOP 186 11/03/23		2090-00-0000-22510-000000-000000		2,017.50		
400684	11/03/2023	EFT	004146 FOP Ohio Labor Council	655.80			
	144759		2090-00-0000-22510-000000-000000		487.48		
	144759		2100-00-0000-22510-000000-000000		168.32		
400685	11/03/2023	EFT	000273 Frost Brown Todd LLC	6,000.00			
	November 1, 2023		1010-AD-AD00-53110-000000-		6,000.00		
400686	11/03/2023	EFT	000277 Galls, LLC	1,324.71			
	BC1978826		2090-PD-PD00-54720-BPVEST-		1,066.59		
	BC1976022		2090-PD-PD00-54720-000000-		258.12		
400687	11/03/2023	EFT	000280 Gateway Tire Company Inc.	584.00			
	30-0617450		2010-RD-RD00-53510-000000-		584.00		
400688	11/03/2023	EFT	000332 Industrial Communication	1,821.97			
	IC-139442		1010-AD-AD00-54010-000000-		607.32		
	IC-139442		2090-PD-PD00-54010-000000-		607.32		
	IC-139442		2100-FD-FD00-54010-000000-		607.33		
400689	11/03/2023	EFT	003949 Jendco Inc	26.67			
	271399		2010-RD-RD00-54550-000000-		26.67		
400690	11/03/2023	EFT	000359 Controls Center Inc	34.01			
	S103024219.001		1010-SV-SV99-54550-000000-		34.01		

AP CHECK RECONCILIATION REGISTER

FOR CASH ACCOUNT: 9999-00-0000-10110-000000-000000

FOR: All Except Stale

CHECK #	CHECK DATE	TYPE	VENDOR NAME	UNCLEARED	CLEARED	BATCH	CLEAR DATE
400691	11/03/2023	EFT	004175 Kennedy Industries Fulfil	109.69			
			INVOICE NO ACCOUNT AMOUNT				
			345416 2090-PD-PD00-53560-000000-		109.69		
400692	11/03/2023	EFT	001300 The Kleingers Group, Inc.	15,150.00			
	85107		2190-00-0000-57010-000000-		15,150.00		
400693	11/03/2023	EFT	000381 Lakota Local School Distr	3,214,619.26			
	1420		2190-00-0000-56070-000000-		1,856,979.49		
	1420		2170-00-0000-56070-000000-		720,467.04		
	1420		2160-00-0000-56070-000000-		50,597.96		
	1420		2150-00-0000-56070-000000-		456,554.03		
	1420		2140-00-0000-56070-000000-		85,521.39		
	1420		2130-00-0000-56070-000000-		44,499.35		
400694	11/03/2023	EFT	002698 Lexipol LLC	17,394.00			
	INVLEX120013		2090-PD-PD00-54830-000000-		17,394.00		
400695	11/03/2023	EFT	003210 Mathewsgroup	614.75			
	230410		2070-PI-PI00-56020-000000-		614.75		
400696	11/03/2023	EFT	002441 Menard, Inc.	136.13			
	70929		1010-SV-SV99-54010-000000-		43.44		
	71049		1010-AD-AD00-53530-000000-		92.69		
400697	11/03/2023	EFT	002949 Mike's Carwash	1,800.00			
	52199		2090-PD-PD00-53510-000000-		1,800.00		
400698	11/03/2023	EFT	000447 Murphy Supply Company	1,227.92			
	209887		2100-FD-FD00-54550-000000-		1,227.92		
400699	11/03/2023	EFT	003479 Prudential Retirement Ins	1,570.00			
	003518 11/03/23		2100-00-0000-22520-000000-000000		1,570.00		
400700	11/03/2023	EFT	000508 Safety Shoe Distributors	409.98			
	I200-21077597		1010-PK-PK00-54720-000000-		150.00		
	I200-21077829		2010-RD-RD00-54720-000000-		259.98		
400701	11/03/2023	EFT	000536 Superior Implement Supply	58.35			
	719137		1010-PK-PK00-53560-000000-		58.35		
400702	11/03/2023	EFT	003946 The Millcraft Paper Compa	190.00			
	CSI3251430		1010-AD-AD00-54510-000000-		205.00		
	CSC2058470		1010-AD-AD00-54510-000000-		-7.50		
	CSC2058494		1010-AD-AD00-54510-000000-		-7.50		
400703	11/03/2023	EFT	003909 City of Trenton	1,690.00			
	10/28/23 A		2090-PD-PD00-51120-000000-		260.00		
	10/28/23 B		2090-PD-PD00-51120-000000-		1,040.00		
	10/28/23 C		2090-PD-PD00-51120-000000-		390.00		

AP CHECK RECONCILIATION REGISTER

FOR CASH ACCOUNT: 9999-00-0000-10110-000000-000000

FOR: All Except Stale

CHECK #	CHECK DATE	TYPE	VENDOR NAME	UNCLEARED	CLEARED	BATCH	CLEAR DATE
400704	11/03/2023	EFT	000573 Valley Asphalt Corporatio	1,405.60			
		INVOICE NO	ACCOUNT		AMOUNT		
		120426	1010-PK-PK03-53530-000000-		1,214.10		
		120427	1010-PK-PK03-53530-000000-		76.00		
		121243	2010-RD-RD00-54550-IHPAVE-		115.50		
400705	11/03/2023	EFT	000583 Vogelpohl Fire Equipment,	412.60			
	4008783		2100-FD-FD00-57050-000000-		412.60		
400706	11/03/2023	EFT	001387 white Cap LP	156.00			
	10018992282		2010-RD-RD00-54550-000000-		156.00		
		97 CHECKS	CASH ACCOUNT TOTAL	3,952,292.08	.00		

AP CHECK RECONCILIATION REGISTER

		UNCLEARED	CLEARED
97 CHECKS	FINAL TOTAL	3,952,292.08	.00

** END OF REPORT - Generated by Felicia Krutka **

AGENDA ITEM COVER SHEET



Trustee Meeting Date:	Agenda Item Type:
November 14, 2023	Requisition Item
Submitted By:	
Larry D. Burks, Township Administrator	

Motion:
Ohio Township Association Risk Management Authority (OTARMA) - \$379,729.00 - Purchase liability and property insurance coverage

Background:												
<p>The Township first joined the Ohio Township Association Risk Management Authority (OTARMA) by contract in 1990. Throughout the years, through a process with Township representatives and insurance agents, the Township validated property values and liabilities to ensure it was adequately covered and represented in its insurance liability needs.</p> <p>Generally, Township liability costs fluctuate with increasing assets of real property, facilities, and equipment and expanding services and operations. The Township’s premium for this renewal year with a CDL test credit is \$379,729.00. The total cost this year is up approximately 10%. The majority is coming from property value increase (from \$97,449,125 to \$111,197,435) and auto value increase (from \$17,646,654 to \$20,213,134), as well as a 5% auto physical damage and property rate increase, driven by the industry. The casualty rates were kept flat. There was an exposure increase for law enforcement coverage, as the township went from 83 to 95 full-time officers.</p> <p>Again this year, the Township will enjoy a disbursement from the OTARMA reserve fund in the amount of \$12,988.89, reimbursable after initial payment. After all is reconciled, the total cost to the Township will be \$366,740.11.</p> <p>Below is a table showing a four-year comparison.</p> <p>Year Total Cost (Total after credits and distributions)</p> <table border="1"> <tr> <td>2020-2021</td> <td>\$309,726.00</td> <td>\$288,146.36</td> </tr> <tr> <td>2021-2022</td> <td>\$325,386.00</td> <td>\$304,162.07</td> </tr> <tr> <td>2022-2023</td> <td>\$340,590.00</td> <td>\$327,374.50</td> </tr> <tr> <td>2023-2024</td> <td>\$379,329.00</td> <td>\$366,740.11</td> </tr> </table>	2020-2021	\$309,726.00	\$288,146.36	2021-2022	\$325,386.00	\$304,162.07	2022-2023	\$340,590.00	\$327,374.50	2023-2024	\$379,329.00	\$366,740.11
2020-2021	\$309,726.00	\$288,146.36										
2021-2022	\$325,386.00	\$304,162.07										
2022-2023	\$340,590.00	\$327,374.50										
2023-2024	\$379,329.00	\$366,740.11										

Finance	Budgeted Item:	Operational		
	CIP #:			
	TIF Info:			
	Purchase Order:	23001975	Total Encumbrance:	\$ 379,729.00

OHIO TOWNSHIP ASSOCIATION RISK MANAGEMENT AUTHORITY (OTARMA)



2023 Property Valuations

OTARMA has made it a priority to help its members maintain accurate replacement cost values for township structures. In 2018 your township received a formal property valuation through CBIZ Valuation Group LLC (CBIZ). This process proved to be extremely beneficial for the OTARMA membership, as it provided accurate replacement cost values for township buildings and contents.

For your 2023 OTARMA renewal we have engaged with CBIZ once again to provide updated replacement cost values, using a detailed trending approach. This approach considers the current cost of reproducing the appraised assets, including labor, material, and overhead costs. Due to rising cost of construction, we have increased each of your building values to an appropriate replacement cost based on this valuation process.

The statement of values within your renewal proposal includes these updated values. Once the Information Acknowledgment Form is completed with your renewal, these new values will go into effect at your anniversary date.

Please reach out to us anytime if you would like to discuss this in more detail. Thank you for your loyal OTARMA membership. We look forward to continuing to serve you.

OTARMA Announces \$800,000 Dollar Distribution in 2023

Dear OTARMA Member,

The OTARMA Board of Directors is pleased to announce that OTARMA will distribute excess reserve funds to all of its members. In 2023, the total distribution amount is **\$800,000!**

Because of conservative investment strategies, an active loss control program, and positive claims experience, the reserve fund that OTARMA must maintain to pay unexpected claims has grown over the years. After consultation with OTARMA's service providers, the OTARMA Board of Directors elected to use a small portion of the reserve fund to distribute a dividend to OTARMA's loyal member townships.

Your Township's portion of the distribution is shown below. In 30-60 days following your OTARMA renewal, a check for this amount will be mailed to you.



Ohio Township Association Risk Management Authority
6500 Taylor Road
Blacklick, OH 43004

Date: 12/1/2023

Memo: **2023 Capital Distribution**

Member Number: 000354

Pay to the order of: West Chester Township, Butler County

Amount: \$12,988.89

Providing coverage to Ohio Townships for over 30 years is a milestone we are extremely proud of. Since OTARMA's inception in 1987, rates have not increased, which is a reflection of the program's long-term stability.

It is your commitment and loyalty that has helped OTARMA become the premier property and liability program in Ohio – the *only* program endorsed by the Ohio Township Association.

Thank YOU for your continued support!

OTARMA Service Center • 315 S. Kalamazoo Mall • Kalamazoo, MI 49007
Telephone: 1-888-748-7966 x3136 • Fax: 1-269-276-4095
www.OTARMA.org



OHIO TOWNSHIP ASSOCIATION RISK MANAGEMENT
AUTHORITY
Service Center
315 S. Kalamazoo Mall
Kalamazoo, MI 49007-4806

November 09, 2023

West Chester Township, Butler County
9113 Cincinnati Dayton Rd
West Chester, OH 45069-4852

Dear Member:

I've enclosed your anniversary coverage outline and contribution invoice. To continue your membership and coverage, please return the following items in the enclosed envelope, by or prior to your anniversary date of **12/01/2023**:

- Anniversary payment
- Original signed Anniversary Information Acknowledgement form
- Any schedule changes on a separate sheet of paper (required for endorsement)

Once all of the above information has been received, your anniversary agreement will be issued and mailed to you. If you have any questions, please contact your local OTARMA representative, or call me at 1.888.748.7966, ext. 3136.

As always, it is our pleasure serving you. Thank you for your loyalty to OTARMA. Together, we will continue to lead the way for Ohio Townships.

Sincerely,

Wendy French
Customer Service Representative
wf/enclosures



OHIO TOWNSHIP ASSOCIATION RISK MANAGEMENT AUTHORITY
Service Center
315 S. Kalamazoo Mall
Kalamazoo, MI 49007-4806

INVOICE

Date: 11/9/2023

West Chester Township, Butler County
9113 Cincinnati Dayton Rd
West Chester, OH 45069-4852

Effective Date	Description	Amount
12/1/2023	2023-2024 Anniversary Contribution	\$379,729

Please check the appropriate box for any options you would like to purchase and write the additional amount in the space provided to calculate your new invoice balance.

Increased Liability Limits to \$11,000,000	\$1,060	<input type="checkbox"/> _____
Increased Liability Limits to \$12,000,000	\$2,120	<input type="checkbox"/> _____
Increased Liability Limits to \$13,000,000	\$3,114	<input type="checkbox"/> _____

INVOICE BALANCE \$ _____

Payment due upon receipt.



Anniversary Information Acknowledgement

The undersigned representative of the West Chester Township, Butler County acknowledges that he/she:

- Reviewed the information provided on all Ohio Township Association Risk Management Authority applications and all applicable supplemental applications.
- Reviewed all applicable property and vehicle schedules.
- Confirms, to the best of his/her knowledge, that all information provided is complete and accurate.
- Reviewed the optional coverage(s) offered by the Ohio Township Association Risk Management Authority for increased limits. After consideration of the coverage(s) offered and the contribution for same, West Chester Township, Butler County has elected to:
 - Waive any and all coverage(s) and any applicable contribution charges. West Chester Township, Butler County understands that to add increased limits coverage in the future, it will be subject to Ohio Township Association Risk Management Authority's approval and underwriting guidelines at the time of the request and that such request must be made in writing. In addition, West Chester Township, Butler County will not hold the Ohio Township Association Risk Management Authority responsible for this decision to waive optional coverage(s).
 - Accept the increased limits: _____
(Limit of Liability Accepted)

Executed on the _____ day of _____, in the year _____, by the undersigned duly authorized officer of the Governmental Subdivision West Chester Township, Butler County indicated below:

By: _____

Title: _____

Member: West Chester Township, Butler County

Member Number: 0354

Anniversary Date: 12/01/2023



SUMMARY OF COVERAGES

FOR

West Chester Township, Butler County

PREPARED BY:

RiskSource Clark-Theders Insurance Agency

Burnham & Flower of Ohio

6500 Taylor Road
Blacklick, OH 43004
800.748.0554

<http://otarma.org>



FOR: West Chester Township, Butler County

EFFECTIVE: 12/01/2023

Broad definition of a “member” which includes:

- Any member of the governing body,
- Any member of boards or commissions,
- Any elected or appointed official,
- Any employee acting within the scope of their employment,
- Any volunteer or student who performs a service for you at your request

SUMMARY OF COVERAGE LIMITS

We will pay those amounts that a member becomes legally obligated to pay as damages, caused by an occurrence to which this Agreement applies:

Legal Liability for General Liability Claims	\$10,000,000 Each occurrence \$0 Deductible
	<ul style="list-style-type: none">• <i>Advertising injury, bodily injury, personal injury, or property damage, arising out of your covered operations or premises.</i>
Legal Liability for Automobile Claims	\$10,000,000 Each occurrence \$0 Deductible
	<ul style="list-style-type: none">• <i>Ownership, maintenance or use of an automobile in the conduct of your covered operations.</i>
Legal Liability for Law Enforcement Claims	\$10,000,000 Each occurrence \$4,000 Deductible
	<ul style="list-style-type: none">• <i>Bodily injury, personal injury or property damage, arising out of your law enforcement operations.</i>
Public Officials Wrongful Acts	\$10,000,000 Each occurrence \$2,500 Deductible
	<ul style="list-style-type: none">• <i>A public officials wrongful act rendered in discharging duties on your behalf.</i>

No aggregate limit on any major lines of coverage unless indicated in the schedule of benefits.



FOR: West Chester Township, Butler County

EFFECTIVE: 12/1/2023

Property Coverages

Blanket Total Insured Values	\$97,775,778	
Building	\$96,653,824	\$1,000 Deductible
Personal Property	\$1,367,403	\$1,000 Deductible
Miscellaneous Property Scheduled	\$9,177,371	\$500 Deductible
EDP - Hardware	\$1,924,958	\$500 Deductible
Miscellaneous Property Unscheduled	\$2,073,879	\$500 Deductible
Total Insured Value		\$111,197,435

Earthquake Limit	\$30,000,000
Deductible	\$25,000

Equipment Breakdown Property Damage	\$98,021,227
Deductible	\$1,000

Crime Coverage

Crime Limit	\$100,000
Deductible	\$500

Faithful Performance of Duty Coverage

Limit	\$250,000
Deductible	\$0

Title	Name
Fiscal Officer	Bruce Jones
Trustee	Ann Becker
Trustee	Lee Wong
Trustee	Mark S. Welch



FOR: West Chester Township, Butler County

EFFECTIVE: 12/1/2023

Automobile Coverages

Liability

Legal Liability for Automobile Claims	\$10,000,000
Covered Pollution Cost or Expense for Automobiles	\$10,000,000
Medical Expenses - Automobile	\$1,000
Uninsured and Underinsured Motorist Per Person	\$100,000
Uninsured and Underinsured Motorist Per Occurrence	\$100,000

Physical Damage

Total Insured Value	\$20,213,134
Comprehensive Deductible	\$500
Collision Deductible	\$500

Cyber Coverages

Cyber Liability	\$1,000,000 occurrence/aggregate
Cyber Breach Event Costs per Occurrence	\$250,000 \$10,000 Deductible
Cyber Breach Event Costs Aggregate	\$250,000
Cyber Crime	\$100,000 \$10,000 Deductible
Telecommunications Fraud Per Occurrence	\$25,000 \$10,000 Deductible
Telecommunications Fraud Aggregate	\$50,000
Post Breach Remediation Costs	\$5,000
Reward Expenses	\$5,000



West Chester Township, Butler County

Effective Date: 12/01/2023

<u>Coverage</u>	<u>Contribution</u>	<u>Limit of Coverage</u>
General Liability	\$44,321	\$10,000,000
Automobile Liability	\$26,208	\$10,000,000
Automobile Physical Damage	\$85,550	\$20,213,134
Law Enforcement Liability	\$31,418	\$10,000,000
Public Officials Wrongful Acts & Employment Practices	\$19,050	\$10,000,000
Excess Liability	\$28,444	Included
Property	\$144,883	\$111,197,435
Equipment Breakdown	Included	Included
Employee Dishonesty	\$0	\$100,000
Faithful Performance of Duty	\$330	\$250,000
Total Contribution	\$380,204	
CDL Credit	\$475.00	
MVR Credit	\$0.00	
Final Contribution	\$379,729.00	

Increased Limits Options

\$11,000,000	\$1,060
\$12,000,000	\$2,120
\$13,000,000	\$3,114



NOTICE

This proposal is an overview of coverages and is merely descriptive and should be used for reference purposes only. Please refer to the coverage document for specific terms, conditions and exclusions. Any questions should be referred to your Account Manager.

CONDITIONS

Flood Coverage Quotes are available upon your written request.

Coverage for the sale of Alcoholic Beverages, Farmers and/or Flea Markets are excluded.



Financial Stability Rating AAA (Unsurpassed)



Endorsed by the Ohio Township Association since 1987. Now serving over 1,000 Ohio townships.



SERVICE CENTER

315 South Kalamazoo Mall
Kalamazoo, MI 49007

Wendy French
Ph. 888.748.7966 Ext. 3136
Fax 269.276.4095
Email: wfrench@bfgroup.com

LOSS CONTROL

KLA Risk Consulting
5890 Sawmill Road, Suite 120
Dublin, OH 43017

Kim Arnold
Ph. 866.537.7775
Email: klarnold@klaconsulting.com

CLAIM SERVICE

Public Entity Risk Services of Ohio, Inc. (PERSO)
6500 Taylor Road, Suite B
Blacklick, OH 43004

Brad Tucker
Ph. 866.907.3776
Fax 614.729.6046
Email: Bradley.Tucker@persopool.com



6500 Taylor Road
Blacklick, OH 43004
800.748.0554

<http://otarma.org>



FOR: West Chester Township, Butler County

EFFECTIVE: 12/1/2023

Legal Defense and Claim Payment Agreement – Schedule of Coverages

Coverage	Effective Date	Limit	Deductible
Legal Liability for Automobile Claims	12/1/2023	\$10,000,000	\$0
Covered Pollution Cost or Expense for Automobiles	12/1/2023	\$10,000,000	\$0
Uninsured and Underinsured Motorist Per Person	12/1/2023	\$100,000	\$0
Uninsured and Underinsured Motorist Per Occurrence	12/1/2023	\$100,000	\$0
Medical Expenses - Automobile	12/1/2023	\$1,000	\$0
Legal Liability for General Liability Claims	12/1/2023	\$10,000,000	\$0
Active Assailant	12/1/2023	See LDCP 0500 (01 19)	\$0
Appeal Bonds	12/1/2023	Unlimited	\$0
Bail Bonds	12/1/2023	Unlimited	\$0
Bonds to Release Property	12/1/2023	Unlimited	\$0
Broad Legal Defense Fund	12/1/2023	\$5,000/\$5,000	\$0
Claim and Defense Expenses	12/1/2023	Unlimited	\$0
Cyber Breach Coverage Aggregate	12/1/2023	\$250,000	\$0
Cyber Breach Coverage Per Occurrence	12/1/2023	\$250,000	\$10,000
Cyber Crime	12/1/2023	\$100,000	\$10,000
Cyber Liability	12/1/2023	\$1,000,000 occurrence/agg regate	\$0
Fungi or Bacteria Clean Up	12/1/2023	\$25,000	\$0
Fungi or Bacteria Clean Up Aggregate	12/1/2023	\$50,000	\$0
Fungi or Bacteria Injury	12/1/2023	\$25,000	\$0
Fungi or Bacteria Injury Aggregate	12/1/2023	\$50,000	\$0
Good Samaritan	12/1/2023	\$10,000,000	\$0
Medical Expenses - Other than Automobile	12/1/2023	\$5,000	\$0
Medical Malpractice	12/1/2023	\$10,000,000	\$0
Member Expenses	12/1/2023	\$10,000	\$0
Moral Obligation to Pay	12/1/2023	\$2,500	\$0
Non-Monetary Relief Defense Expense	12/1/2023	\$50,000	\$0
Post-Judgment Interest	12/1/2023	Unlimited	\$0
Pre-Judgment Interest	12/1/2023	Unlimited	\$0
Stop Gap	12/1/2023	\$10,000,000	\$0
Telecommunications Fraud Aggregate	12/1/2023	\$50,000	\$0
Telecommunications Fraud Per Occurrence	12/1/2023	\$25,000	\$10,000
Pollution Liability Coverage - Pesticides	12/1/2023	\$250,000	0
Public Officials Wrongful Acts	12/1/2023	\$10,000,000	\$2,500
Employee Benefit Liability	12/1/2023	\$1,000,000	\$1,000
Employment Expense	12/1/2023	\$10,000,000	\$0
Employment Practices Wrongful Acts	12/1/2023	\$10,000,000	\$2,500



FOR: West Chester Township, Butler County

EFFECTIVE: 12/1/2023

Legal Defense and Claim Payment Agreement – Schedule of Coverages

Legal Liability for Law Enforcement Claims 12/1/2023 \$10,000,000 \$4,000

<u>Endorsements</u>	<u>Effective Date</u>	<u>Limit</u>	<u>Deductible</u>
Anti-skid Material Storage and Application	12/1/2023	\$10,000,000	\$0
Chlorine	12/1/2023	\$10,000,000	\$0
Fire Department Pollution Coverage	12/1/2023	\$500,000	\$0
Fire Department Training Activities	12/1/2023	\$10,000,000	\$0
Sewer Back-up	12/1/2023	5,000,000 / 5,000,000	\$0
Temporary Depository Site	12/1/2023	\$250,000	\$0
Underground Gasoline, Diesel and Fuel Oil Storage Tanks Aggregate	12/1/2023	\$55,000	\$0
Underground Gasoline, Diesel and Fuel Oil Storage Tanks Each Occurrence	12/1/2023	\$55,000	\$0



GOVERNMENT PROPERTY AGREEMENT – SCHEDULE OF BENEFITS

Ohio Township Association Risk Management Authority

West Chester Township, Butler County

Effective Date: 12/01/2023

SECTION	COVERAGE LIMIT	DEDUCTIBLE
SECTION III – PROPERTY DAMAGE		
Buildings*	\$96,653,824	\$1,000
Personal Property*	\$1,367,403	\$1,000
Accounts Receivable	\$250,000	
Animals	\$25,000	
Appearance Allowance	\$25,000	
Arson or Theft Reward	\$10,000	
Athletic Surfaces	\$50,000	
Building or Addition Under Construction	\$1,000,000	\$1,000
Building or Addition Under Construction - Frame Construction Type	Excluded	
Cemetery Property	\$10,000	\$0
Debris Removal	\$250,000	
Decontamination Costs	\$25,000	
Electronic Vandalism	\$250,000	
Equipment Rental Reimbursement	\$250,000	
Errors or Omissions	\$500,000	
Expediting Expenses	\$250,000	
Fine Arts - Unscheduled	\$25,000	
Fire Department Service Charge	Actual Cost	
Fire Extinguishing Systems	Actual Cost	
Fire Hydrants (Unscheduled)	\$10,000	
Golf Course Sand Traps, Tee and Greens	10,000/250,000	
Green Coverage	\$100,000	
Guide Rails	\$10,000	
Land and Water Cleanup Expense	\$10,000	
Locks and Keys	\$25,000	

GOVERNMENT PROPERTY AGREEMENT – SCHEDULE OF BENEFITS

Ohio Township Association Risk Management Authority

West Chester Township, Butler County

Effective Date: 12/01/2023

SECTION	COVERAGE LIMIT	DEDUCTIBLE
Money and Securities	\$25,000	
New Generation	\$10,000	
Newly Constructed or Acquired Property	\$2,000,000	\$1,000
Off-Premises Service Interruption Property Damage	\$25,000	
Off-Premises Storage - Property Under Construction	\$10,000	
Ordinance or Law	\$500,000	
Outdoor Signs	\$10,000	
Outdoor Trees and Shrubs	10,000/250,000	
Parking Meters and Charging Stations	\$5,000	
Personal Prop Not at a Covered Location	\$50,000	
Personal Property at Newly Acquired or Leased Locations	\$1,000,000	\$0
Personal Property of Others	\$250,000	\$1,000
Pollution Cleanup Expense	\$100,000	
Professional Fees	\$5,000	
Property Removed from a Covered Location	\$250,000	
Protection and Preservation of Property	\$250,000	
Terrorism	See GPA 0780	\$0
Transit Coverage	\$100,000	
Underground Fiber Optic Cable	\$10,000	
Unscheduled Misc Property	\$10,000	
Unscheduled Playground Equipment	\$25,000	
Unscheduled Property in the Open	\$100,000	\$1,000
Valuable Papers and Records	\$250,000	
Water and Sewer Backup	\$100,000	

GOVERNMENT PROPERTY AGREEMENT – SCHEDULE OF BENEFITS

Ohio Township Association Risk Management Authority

West Chester Township, Butler County

Effective Date: 12/01/2023

SECTION	COVERAGE LIMIT	DEDUCTIBLE
SECTION IV - TIME ELEMENT		
Civil Authority	Maximum 30 days	
Civil Authority	\$25,000	
Computer Systems and Non-physical Damage	\$10,000	
Contingent Tax Revenue Interruption	\$25,000	
Contingent Time Element	\$10,000	
Earnings During Protection/Preservation	\$25,000	
Expenses to Reduce Loss	\$25,000	
Extended Earnings, Extra Expense and Cost	\$50,000	
Extended Gross Earnings, Extra Expense and Cost	Maximum 180 days	
Extended Period of Coverage	\$25,000	
Extra Expense and Cost	\$250,000	
Gross Earnings	\$250,000	
Leasehold Interest	\$10,000	
Rental Coverage	\$10,000	
Soft Costs	\$5,000	
Storm Debris Removal	\$5,000	

GOVERNMENT PROPERTY AGREEMENT – SCHEDULE OF BENEFITS

Ohio Township Association Risk Management Authority

West Chester Township, Butler County

Effective Date: 12/01/2023

SECTION	COVERAGE LIMIT	DEDUCTIBLE
---------	----------------	------------

SECTION V - EQUIPMENT BREAKDOWN

Total Limit per one Breakdown*	\$98,021,227	See GPA 0644
Power Generating Equipment	Excluded	
Civil Authority	\$25,000	
Data or Media	\$250,000	
Defense	Unlimited	
Dependent Properties	\$25,000	
Earnings	\$100,000	
Electrical Surge and Electrical Disturbance	\$100,000	
Error in Description	\$500,000	
Expediting Expenses	\$250,000	
Extended Earnings and Extra Expense	\$100,000	
Extra Expense	\$100,000	
Green Alternatives	\$100,000	
Hazardous Substance	\$100,000	
New Generation	\$10,000	
Newly Acquired Locations	\$2,000,000	
Off Premises Equipment	\$50,000	
Ordinance or Law	\$500,000	
Refrigerant Contamination	\$100,000	
Service Interruption	\$100,000	
Spoilage	Included with Refrigerant Contamination	
Water Damage	\$100,000	

SECTION VI – CRIME

Crime	\$100,000	\$500
Faithful Performance of Duty	\$250,000	\$0
Computer Fraud and Funds Transfer	\$100,000	\$500
Employee Theft - Per Employee	\$100,000	\$500
Employee Theft - Per Loss	\$100,000	\$500
Forgery or Alteration	\$100,000	\$500
Inside Premises - Robbery or Safe Burglary	\$100,000	\$500
Money Orders and Counterfeit Money	\$100,000	\$500
Outside Premises	\$100,000	\$500
Theft, Disappearance, Destruction of Money	\$100,000	\$500

GOVERNMENT PROPERTY AGREEMENT – SCHEDULE OF BENEFITS

Ohio Township Association Risk Management Authority

West Chester Township, Butler County

Effective Date: 12/01/2023

SECTION	COVERAGE LIMIT	DEDUCTIBLE
SECTION VII - AUTOMOBILE PHYSICAL DAMAGE		
Airbags	\$5,000	
Commandeered Property	\$250,000	
Emergency Response Automobile	\$25,000	
Freezing of Equipment Coverage	\$25,000	
Hired Automobile Physical Damage	\$50,000	
Lease Gap	\$25,000	
Not At Fault Collision Deductible Waiver	\$2,500	
Personal Automobile (Deductible)	Actual Cost	
Property in an Unattended Auto	\$1,000	
Recertification	Actual Cost	
Rental Automobile Agreement	\$10,000	
Rental Reimbursement Aggregate	\$100,000	
Rental Reimbursement Per Day	\$1,000	
Roadside Assistance	\$5,000	
Temporary Substitute Automobile	\$2,500	
Terrorism	See GPA 0780	

GOVERNMENT PROPERTY AGREEMENT – SCHEDULE OF BENEFITS

Ohio Township Association Risk Management Authority

West Chester Township, Butler County

Effective Date: 12/01/2023

SECTION	COVERAGE LIMIT	DEDUCTIBLE
SECTION VIII - EARTH MOVEMENT		
Earthquake	\$30,000,000	\$25,000
Earth Movement Accounts Receivable	\$250,000	
Earth Movement Animals	\$25,000	
Earth Movement Athletic Surfaces	\$50,000	\$1,000
Earth Movement Debris Removal	\$250,000	
Earth Movement Decontamination Costs	\$25,000	
Earth Movement Expediting Expense	\$250,000	
Earth Movement Fine Arts - Unscheduled	\$25,000	
Earth Movement Fire Department Service Charge	Actual Cost	
Earth Movement Fire Extinguishing Systems	Actual Cost	
Earth Movement Green Coverage	\$100,000	
Earth Movement Locks and Keys	\$25,000	
Earth Movement Money and Securities	\$25,000	
Earth Movement Off-Premises Service Interruption Property Damage	\$25,000	
Earth Movement Off-Premises Storage - Property Under Construction	\$10,000	
Earth Movement Ordinance or Law	\$500,000	
Earth Movement Outdoor Signs	\$10,000	
Earth Movement Parking Meters and Charging Stations	\$5,000	
Earth Movement Personal Prop Not at a Covered Location	\$50,000	\$1,000
Earth Movement Personal Property at Newly Acquired or Leased Locations	\$1,000,000	
Earth Movement Professional Fees	\$5,000	
Earth Movement Property Removed from a Covered Location	\$250,000	
Earth Movement Protection and Preservation of Property	\$250,000	
Earth Movement Transit Coverage	\$100,000	
Earth Movement Unscheduled Misc Property	\$10,000	
Earth Movement Unscheduled Playground Equipment	\$25,000	
Earth Movement Valuable Papers and Records	\$250,000	



Statement of Values

West Chester Township, Butler
County

Effective Date: 12/01/2023

Printed on: 11/09/2023

Location Description	Area	# of Firs	Auto Spklr	Year Built	Year Reno	Con Code	Pro Class	Equip Break	FL	EQ	Blank Limit
-											
	Value					Valuation					Deductible
EDP - Hardware	\$1,924,958					RC					\$500
Miscellaneous Property Scheduled	\$9,177,371					RC					\$500
Miscellaneous Property Unscheduled	\$2,073,879					RC					\$500
Total Location TIV	\$13,176,208										
1 - 1 9119 Cincinnati-Dayton Road											
West Chester, OH 450694852											
35533 3 2009 3 3 Y N Y Y											
Fire Station #71 & HQ, Signage, Flagpole & Bollards											
	Value					Valuation					Deductible
Building	\$8,980,600					RC					\$1,000
Personal Property	\$212,276										\$1,000
Total Location TIV	\$9,192,876										
1 - 2 9119 Cincinnati-Dayton Road											
West Chester, OH 450694852											
3847 1 1995 1 3 Y N Y Y											
Salt Dome Storage											
	Value					Valuation					Deductible
Building	\$330,900					RC					\$1,000
Total Location TIV	\$330,900										



Statement of Values

West Chester Township, Butler
County

Effective Date: 12/01/2023

Printed on: 11/09/2023

Location Description	Area	# of Firs	Auto Spklr	Year Built	Year Reno	Con Code	Pro Class	Equip Break	FL	EQ	Blank Limit
2 - 1 9113 Cincinnati-Dayton Road West Chester, OH 450694852 Administration & Trustee Hall	24992	2		1989		4	3	Y	N	Y	Y
	Value					Valuation					Deductible
Building	\$6,211,600					RC					\$1,000
Personal Property	\$254,598										\$1,000
Total Location TIV	\$6,466,198										
2 - 2 9113 Cincinnati-Dayton Road West Chester, OH 450694852 Lighting, Signage, Benches, Fencing, Flagpole & Generators	1	1		1989		3	3	Y	N	Y	Y
	Value					Valuation					Deductible
Building	\$528,800					RC					\$1,000
Total Location TIV	\$528,800										
3 - 1 7715 John Road West Chester, OH 450694852 Fire Station #2 (#72), Flagpole, Lighting & Bollards	12054	2		2002		4	3	Y	N	Y	Y
	Value					Valuation					Deductible
Building	\$3,240,300					RC					\$1,000
Personal Property	\$61,418										\$1,000
Total Location TIV	\$3,301,718										



Statement of Values

West Chester Township, Butler
County

Effective Date: 12/01/2023

Printed on: 11/09/2023

Location Description	Area	# of Firs	Auto Spklr	Year Built	Year Reno	Con Code	Pro Class	Equip Break	FL	EQ	Blank Limit
4 - 1 4850 Duff Drive West Chester, OH 452461124 New Fire Station #3 (#73), Flagpole, Antenna & Siren	9800	1		2021		4	3	Y	N	Y	Y
	Value					Valuation					Deductible
Building	\$1,460,700					RC					\$1,000
Personal Property	\$27,797										\$1,000
Total Location TIV	\$1,488,497										
5 - 1 6425 West Chester Road West Chester, OH 450694852 Cemetery Chapel	960	2		1938		1	3	Y	N	Y	Y
	Value					Valuation					Deductible
Building	\$132,600					RC					\$1,000
Total Location TIV	\$132,600										
5 - 2 6425 West Chester Road West Chester, OH 450694852 Cemetery Headstones	0	1				2	3	Y	N	Y	Y
	Value					Valuation					Deductible
Building	\$37,319					RC					\$1,000
Total Location TIV	\$37,319										



Statement of Values

West Chester Township, Butler
County

Effective Date: 12/01/2023

Printed on: 11/09/2023

Location Description	Area	# of Firs	Auto Spklr	Year Built	Year Reno	Con Code	Pro Class	Equip Break	FL	EQ	Blank Limit
5 - 3 6425 West Chester Road West Chester, OH 450694852 Cemetery Tool Shed #2	153	1		1920		1	3	Y	N	Y	Y
	Value					Valuation					Deductible
Building	\$15,631					RC					\$1,000
Total Location TIV	\$15,631										
5 - 4 6425 West Chester Road West Chester, OH 450694852 Cemetery Tool Shed	384	1		1938		1	3	Y	N	Y	Y
	Value					Valuation					Deductible
Building	\$15,208					RC					\$1,000
Total Location TIV	\$15,208										
6 - 1 Keehner Park: 7211-7411 Barret Road West Chester, OH 450694852 Amphitheatre Stage, Storage Facility & Trash Receptacles	2305	2		1997		2	3	Y	N	Y	Y
	Value					Valuation					Deductible
Building	\$604,200					RC					\$1,000
Personal Property	\$325										\$1,000
Total Location TIV	\$604,525										



Statement of Values

West Chester Township, Butler
County

Effective Date: 12/01/2023

Printed on: 11/09/2023

Location Description	Area	# of Firs	Auto Spklr	Year Built	Year Reno	Con Code	Pro Class	Equip Break	FL	EQ	Blank Limit
6 - 10 Keehner Park: 7211-7411 Barret Road West Chester, OH 450694852 Small Shelter House #1 & Picnic Tables (Fox)	520	1		1991		1	3	Y	N	Y	Y
	Value					Valuation					Deductible
Building	\$35,000					RC					\$1,000
Total Location TIV	\$35,000										
6 - 11 Keehner Park: 7211-7411 Barret Road West Chester, OH 450694852 Small Shelter House #2 & Picnic Tables (Hawk)	520	1		1991		1	3	Y	N	Y	Y
	Value					Valuation					Deductible
Building	\$35,000					RC					\$1,000
Total Location TIV	\$35,000										
6 - 2 Keehner Park: 7211-7411 Barret Road West Chester, OH 450694852 Log Cabin Museum	570	1		1830		1	3	Y	N	Y	Y
	Value					Valuation					Deductible
Building	\$85,500					RC					\$1,000
Personal Property	\$150										\$1,000
Total Location TIV	\$85,650										



Statement of Values

West Chester Township, Butler
County

Effective Date: 12/01/2023

Printed on: 11/09/2023

Location Description	Area	# of Flrs	Auto Spklr	Year Built	Year Reno	Con Code	Pro Class	Equip Break	FL	EQ	Blank Limit
6 - 3 Keehner Park: 7211-7411 Barret Road West Chester, OH 450694852 Restroom #1	320	1		1988		2	3	Y	N	Y	Y
	Value					Valuation					Deductible
Building	\$74,700					RC					\$1,000
Total Location TIV	\$74,700										
6 - 4 Keehner Park: 7211-7411 Barret Road West Chester, OH 450694852 Restroom #2	320	1		1988		2	3	Y	N	Y	Y
	Value					Valuation					Deductible
Building	\$74,700					RC					\$1,000
Total Location TIV	\$74,700										
6 - 5 Keehner Park: 7211-7411 Barret Road West Chester, OH 450694852 Playground, Signage, Flagpole, Fencing, Multi- Use Courts, Athletic Equip, Bollards	1	1		2017		3	3	Y	N	Y	Y
	Value					Valuation					Deductible
Building	\$227,517					RC					\$1,000
Total Location TIV	\$227,517										



Statement of Values

West Chester Township, Butler
County

Effective Date: 12/01/2023

Printed on: 11/09/2023

Location Description	Area	# of Firs	Auto Spklr	Year Built	Year Reno	Con Code	Pro Class	Equip Break	FL	EQ	Blank Limit
6 - 6 Keehner Park: 7211-7411 Barret Road West Chester, OH 450694852 Shelter House & Picnic Tables (Coyote)	720	1		1991		1	3	Y	N	Y	Y
	Value					Valuation					Deductible
Building	\$35,000					RC					\$1,000
Total Location TIV	\$35,000										
6 - 7 Keehner Park: 7211-7411 Barret Road West Chester, OH 450694852 Shelter House & Picnic Tables (Owl)	720	1		1988		1	3	Y	N	Y	Y
	Value					Valuation					Deductible
Building	\$35,000					RC					\$1,000
Total Location TIV	\$35,000										
6 - 8 Keehner Park: 7211-7411 Barret Road West Chester, OH 450694852 Shelter House & Picnic Tables (Amph)	720	1		1993		1	3	Y	N	Y	Y
	Value					Valuation					Deductible
Building	\$35,000					RC					\$1,000
Total Location TIV	\$35,000										



Statement of Values

West Chester Township, Butler
County

Effective Date: 12/01/2023

Printed on: 11/09/2023

Location Description	Area	# of Flrs	Auto Spklr	Year Built	Year Reno	Con Code	Pro Class	Equip Break	FL	EQ	Blank Limit
6 - 9 Keehner Park: 7211-7411 Barret Road West Chester, OH 450694852 Shelter House & Picnic Tables (Deer)	720	1		1993		1	3	Y	N	Y	Y
	Value					Valuation					Deductible
Building	\$35,000					RC					\$1,000
Total Location TIV	\$35,000										
9 - 1 8070 Tylersville Road West Chester, OH 450694852 VOA Building, Signage, Flagpole, Fencing, Lighting & Generator	32532	2		1943		6	3	Y	N	Y	Y
	Value					Valuation					Deductible
Building	\$13,025,800					RC					\$1,000
Total Location TIV	\$13,025,800										
9 - 2 8070 Tylersville Road West Chester, OH 450694852 VOA Garage & Storage	2640	1		1998		3	3	Y	N	Y	Y
	Value					Valuation					Deductible
Building	\$210,100					RC					\$1,000
Personal Property	\$500										\$1,000
Total Location TIV	\$210,600										



Statement of Values

West Chester Township, Butler
County

Effective Date: 12/01/2023

Printed on: 11/09/2023

Location Description	Area	# of Firs	Auto Spklr	Year Built	Year Reno	Con Code	Pro Class	Equip Break	FL	EQ	Blank Limit
10 - 1 8551 Beckett Road West Chester, OH 450694852 Fire Station #4 (#74), Lighting Flagpole, Siren & Bollards	8340	1		1999		4	3	Y	N	Y	Y
	Value					Valuation					Deductible
Building	\$2,205,500					RC					\$1,000
Personal Property	\$38,462										\$1,000
Total Location TIV	\$2,243,962										
11 - 1 7588 Tylers Place Boulevard West Chester, OH 450694852 Fire Station #5 (#75), Lighting, Flagpole & Siren	7053	1		1999		4	3	Y	N	Y	Y
	Value					Valuation					Deductible
Building	\$1,862,200					RC					\$1,000
Personal Property	\$21,174										\$1,000
Total Location TIV	\$1,883,374										
16 - 1 9577 Beckett Road West Chester, OH 450694852 Safety & Services Center, Flagpole, Generator, Chemical & Fuel Tanks (PD, Pks, Serv, Rd, ComDev)	186045	1		1996		3	3	Y	N	Y	Y
	Value					Valuation					Deductible
Building	\$42,830,600					RC					\$1,000
Personal Property	\$528,254										\$1,000
Total Location TIV	\$43,358,854										



Statement of Values

West Chester Township, Butler
County

Effective Date: 12/01/2023

Printed on: 11/09/2023

Location Description	Area	# of Firs	Auto Spklr	Year Built	Year Reno	Con Code	Pro Class	Equip Break	FL	EQ	Blank Limit
16 - 2 9577 Beckett Road West Chester, OH 450694852 Salt Dome (Storage)	5024	1		2003		1	3	Y	N	Y	Y
	Value					Valuation					Deductible
Building	\$420,600					RC					\$1,000
Total Location TIV	\$420,600										
16 - 3 9577 Beckett Road West Chester, OH 450694852 Fuel Station	1596	1		2003		4	3	Y	N	Y	Y
	Value					Valuation					Deductible
Building	\$228,100					RC					\$1,000
Total Location TIV	\$228,100										
17 - 1 Various - Throughout West Chester Township West Chester, OH 450694852 Illuminated Signs, Preemption Devices, Street Lights as per schedule on file	0	1		2009		4	3	Y	N	Y	Y
	Value					Valuation					Deductible
Building	\$1,094,062					RC					\$1,000
Total Location TIV	\$1,094,062										



Statement of Values

West Chester Township, Butler
County

Effective Date: 12/01/2023

Printed on: 11/09/2023

Location Description	Area	# of Firs	Auto Spklr	Year Built	Year Reno	Con Code	Pro Class	Equip Break	FL	EQ	Blank Limit
17 - 2 Various - Throughout West Chester Township											
West Chester, OH 450694852 Signs, Fences & Sprinkler System	0	1				3	3	Y	N	Y	Y
	Value					Valuation					Deductible
Building	\$74,635					RC					\$1,000
	Total Location TIV										\$74,635
17 - 3 Various - Throughout West Chester Township											
West Chester, OH 450694852 Emergency Warning Siren Towers	0	1				3	3	Y	N	Y	Y
	Value					Valuation					Deductible
Building	\$40,415					RC					\$1,000
	Total Location TIV										\$40,415
17 - 4 Various - Throughout West Chester Township											
West Chester, OH 450694852 Set of (2) Crosswalk Beacons	1	1		2019		3	3	Y	N	Y	Y
	Value					Valuation					Deductible
Building	\$10,841					RC					\$1,000
	Total Location TIV										\$10,841



Statement of Values

West Chester Township, Butler
County

Effective Date: 12/01/2023

Printed on: 11/09/2023

Location Description	Area	# of Firs	Auto Spklr	Year Built	Year Reno	Con Code	Pro Class	Equip Break	FL	EQ	Blank Limit	
17 - 5 Various - Throughout West Chester Township												
West Chester, OH 450694852	1	1				3	3	Y	N	Y	Y	
Traffic Signals, Signage & GPS												
			Value				Valuation					Deductible
Building						RC						\$1,000
Total Location TIV												\$1,158,348
19 - 1 Beckett Park: 8558 Beckett Ridge Boulevard												
West Chester, OH 450694852	10400	2		2008		1	3	Y	N	Y	Y	
Muhlhauser Barn												
			Value				Valuation					Deductible
Building						RC						\$1,000
Personal Property												\$1,000
Total Location TIV												\$1,623,646
19 - 2 Beckett Park: 8558 Beckett Ridge Boulevard												
West Chester, OH 450694852	0	1		2000		1	3	Y	N	Y	Y	
Muhlhauser Barn Gazebo												
			Value				Valuation					Deductible
Building						RC						\$1,000
Total Location TIV												\$37,319



Statement of Values

West Chester Township, Butler
County

Effective Date: 12/01/2023

Printed on: 11/09/2023

Location Description	Area	# of Flrs	Auto Spklr	Year Built	Year Reno	Con Code	Pro Class	Equip Break	FL	EQ	Blank Limit
19 - 3 Beckett Park: 8558 Beckett Ridge Boulevard West Chester, OH 450694852 Muhlhauser Barn Fountain	0	1				1	3	Y	N	Y	Y
	Value					Valuation					Deductible
Building	\$8,027					RC					\$1,000
Total Location TIV	\$8,027										
22 - 1 The Square @ Union Centre: 9285 Centre Pointe Drive West Chester, OH 450694852 Clock Tower	1	1		2008		3	3	Y	N	Y	Y
	Value					Valuation					Deductible
Building	\$808,100					RC					\$1,000
Total Location TIV	\$808,100										
22 - 2 The Square @ Union Centre: 9285 Centre Pointe Drive West Chester, OH 450694852 Restroom	928	1		2008		2	3	Y	N	Y	Y
	Value					Valuation					Deductible
Building	\$216,500					RC					\$1,000
Personal Property	\$175										\$1,000
Total Location TIV	\$216,675										



Statement of Values

West Chester Township, Butler
County

Effective Date: 12/01/2023

Printed on: 11/09/2023

Location Description	Area	# of Firs	Auto Spklr	Year Built	Year Reno	Con Code	Pro Class	Equip Break	FL	EQ	Blank Limit
22 - 3 The Square @ Union Centre: 9285 Centre Pointe Drive West Chester, OH 450694852 Bridge	0	1		2008		4	3	Y	N	N	N
	Value					Valuation					Deductible
Building	\$245,449					RC					\$1,000
Total Location TIV	\$245,449										
22 - 4 The Square @ Union Centre: 9285 Centre Pointe Drive West Chester, OH 450694852 Trellis', Lighting, Benches, Trash Receptacles, Statue & Fountain	1	1		2008		3	3	Y	N	Y	Y
	Value					Valuation					Deductible
Building	\$210,046					RC					\$1,000
Total Location TIV	\$210,046										
26 - 1 6447 West Chester Road West Chester, OH 450694852 Cemetery Garage & Bollards	2450	1		2009		3	3	Y	N	Y	Y
	Value					Valuation					Deductible
Building	\$233,700					RC					\$1,000
Total Location TIV	\$233,700										



Statement of Values

West Chester Township, Butler
County

Effective Date: 12/01/2023

Printed on: 11/09/2023

Location Description	Area	# of Firs	Auto Spklr	Year Built	Year Reno	Con Code	Pro Class	Equip Break	FL	EQ	Blank Limit
27 - 1 Beckett Park: 8650 Union Centre Boulevard West Chester, OH 450694852 Concession, Restrooms, Locker Rooms, & Press Box	3328	2		2008		2	3	Y	N	Y	Y
	Value					Valuation					Deductible
Building	\$510,800					RC					\$1,000
	Total Location TIV										\$510,800
27 - 10 Beckett Park: 8650 Union Centre Boulevard West Chester, OH 450694852 West Shelter w/ Fireplace	1260	1		2011		1	3	Y	N	Y	Y
	Value					Valuation					Deductible
Building	\$223,500					RC					\$1,000
	Total Location TIV										\$223,500
27 - 11 Beckett Park: 8650 Union Centre Boulevard West Chester, OH 450694852 West Water Feature	0	1		2011		2	3	Y	N	Y	Y
	Value					Valuation					Deductible
Building	\$253,475					RC					\$1,000
	Total Location TIV										\$253,475



Statement of Values

West Chester Township, Butler
County

Effective Date: 12/01/2023

Printed on: 11/09/2023

Location Description	Area	# of Firs	Auto Spklr	Year Built	Year Reno	Con Code	Pro Class	Equip Break	FL	EQ	Blank Limit
27 - 12 Beckett Park: 8650 Union Centre Boulevard											
West Chester, OH 450694852	0	1		2011		1	3	Y	N	Y	Y
West Boardwalk, bridge & railing											
			Value			Valuation			Deductible		
Building						RC					\$1,000
Total Location TIV											\$138,003
27 - 13 Beckett Park: 8650 Union Centre Boulevard											
West Chester, OH 450694852	0	1		2011		1	3	Y	N	Y	Y
West Dock & Railing											
			Value			Valuation			Deductible		
Building						RC					\$1,000
Total Location TIV											\$81,675
27 - 14 Beckett Park: 8650 Union Centre Boulevard											
West Chester, OH 450694852	0	1		2011		1	3	Y	N	Y	Y
West Natural											
			Value			Valuation			Deductible		
Building						RC					\$1,000
Total Location TIV											\$10,561



Statement of Values

West Chester Township, Butler
County

Effective Date: 12/01/2023

Printed on: 11/09/2023

Location Description	Area	# of Firs	Auto Spklr	Year Built	Year Reno	Con Code	Pro Class	Equip Break	FL	EQ	Blank Limit
27 - 2 Beckett Park: 8650 Union Centre Boulevard West Chester, OH 450694852 Vinyl Coated Fencing & Gates @ Baseball Complex	0	1		2008		1	3	Y	N	Y	Y
	Value					Valuation					Deductible
Building	\$251,928					RC					\$1,000
											Total Location TIV
	\$251,928										
27 - 3 Beckett Park: 8650 Union Centre Boulevard West Chester, OH 450694852 Baseball Complex Eight (8) Dug Outs	120	1		2008		2	3	Y	N	Y	Y
	Value					Valuation					Deductible
Building	\$87,871					RC					\$1,000
											Total Location TIV
	\$87,871										
27 - 4 Beckett Park: 8650 Union Centre Boulevard West Chester, OH 450694852 Maintenance Building	1000	1		2008		2	3	Y	N	Y	Y
	Value					Valuation					Deductible
Building	\$85,300					RC					\$1,000
											Total Location TIV
	\$85,300										



Statement of Values

West Chester Township, Butler
County

Effective Date: 12/01/2023

Printed on: 11/09/2023

Location Description	Area	# of Firs	Auto Spklr	Year Built	Year Reno	Con Code	Pro Class	Equip Break	FL	EQ	Blank Limit
27 - 5 Beckett Park: 8650 Union Centre Boulevard West Chester, OH 450694852 Backstop System @ Baseball Complex	0	1		2008		4	3	Y	N	Y	Y
	Value					Valuation					Deductible
Building	\$38,022					RC					\$1,000
Total Location TIV	\$38,022										
27 - 6 Beckett Park: 8650 Union Centre Boulevard West Chester, OH 450694852 Scoreboards @ Baseball Complex	0	1		2008		4	3	Y	N	Y	Y
	Value					Valuation					Deductible
Building	\$27,883					RC					\$1,000
Total Location TIV	\$27,883										
27 - 7 Beckett Park: 8650 Union Centre Boulevard West Chester, OH 450694852 Bleachers & Benches @ Baseball Complex	0	1				3	3	Y	N	Y	Y
	Value					Valuation					Deductible
Building	\$21,687					RC					\$1,000
Total Location TIV	\$21,687										



Statement of Values

West Chester Township, Butler
County

Effective Date: 12/01/2023

Printed on: 11/09/2023

Location Description	Area	# of Firs	Auto Spklr	Year Built	Year Reno	Con Code	Pro Class	Equip Break	FL	EQ	Blank Limit
27 - 8 Beckett Park: 8650 Union Centre Boulevard West Chester, OH 450694852 Beckett Park East Shelter (Near 27-9)											
	1260	1		2011		1	3	Y	N	Y	Y
Value			Valuation			Deductible					
Building	\$203,200					RC				\$1,000	
Total Location TIV	\$203,200										
27 - 9 Beckett Park: 8650 Union Centre Boulevard West Chester, OH 450694852 Boundless Playground Equipment											
	0	1		2009		1	3	Y	N	Y	Y
Value			Valuation			Deductible					
Building	\$415,701					RC				\$1,000	
Total Location TIV	\$415,701										
28 - 1 Township Parking Areas & Parks West Chester, OH 450694852 300 Lights/ Poles											
	0	1				1	3	Y	N	Y	Y
Value			Valuation			Deductible					
Building	\$335,401					RC				\$1,000	
Total Location TIV	\$335,401										



Statement of Values

West Chester Township, Butler
County

Effective Date: 12/01/2023

Printed on: 11/09/2023

Location Description	Area	# of Firs	Auto Spklr	Year Built	Year Reno	Con Code	Pro Class	Equip Break	FL	EQ	Blank Limit
32 - 1 9121 Cincinnati-Dayton Road West Chester, OH 450609 Communications (911 Dispatch) & Info Tech Building (IT)	14860	2		2009		4	3	Y	N	Y	Y

	Value	Valuation	Deductible
Building	\$5,219,300	RC	\$1,000
Personal Property	\$197,528		\$1,000
Total Location TIV	\$5,416,828		

Total Blanket TIV	\$97,775,778
Building	\$96,653,824
Personal Property	\$1,367,403
EDP - Hardware	\$1,924,958
Miscellaneous Property Scheduled	\$9,177,371
Miscellaneous Property Unscheduled	\$2,073,879
Total TIV	\$111,197,435



Additional Property Statement of Values

West Chester Township, Butler County

Effective Date: 12/01/2023

Printed on: 11/09/2023

Location Information N/A

Line	Classification	Description	Serial No	Coverage Limit	Valuation	Deductible
1	Miscellaneous Property Scheduled	Salt Spreader for 1 (RD)	S#TR-1	\$6,600	RC	\$500
2	Miscellaneous Property Scheduled	Grasshopper 272 T2 Mower 61" (SERV)		\$12,650	RC	\$500
3	Miscellaneous Property Scheduled	Hot Shot Bulles Digital Fire Ext. Simulator (FD)	S#7195	\$16,500	RC	\$500
4	Miscellaneous Property Scheduled	(2) Cabinet:Key-Morse Watchman's @ 22,645 each (PD)	S#0861 S# TBD	\$49,819	RC	\$500
5	Miscellaneous Property Scheduled	Mako Air Compressor (FD)	S#0385	\$57,200	RC	\$500
6	Miscellaneous Property Scheduled	Plow, Western Pro Plus 9' for small trucks (RD)	S#6901	\$5,500	RC	\$500
7	Miscellaneous Property Scheduled	2021 Polaris Ranger ATV (Police)	S#4080	\$18,698	RC	\$500
8	Miscellaneous Property Scheduled	Pushbox, Pro-Teck Snow Push Box (RD)	S#0387	\$4,950	RC	\$500
9	Miscellaneous Property Scheduled	(2) Exmark 60" LZM Mowers @ 13,190 each (PARKS)	S#5167, S#5967	\$29,018	RC	\$500
10	Miscellaneous Property Scheduled	Smith Detection Hazmat Gas ID (FD)	S#9002	\$73,975	RC	\$500
11	Miscellaneous Property Scheduled	Free Motion T11.3 Treadmill (FD)		\$5,500	RC	\$500
12	Miscellaneous Property Scheduled	3 play 3PI IP Replay System with control surface (2RU) (PIE)	Newtek BDL- 00000007	\$19,995	RC	\$500
13	Miscellaneous Property Scheduled	Genesis C365 Cutter (FD)	S#0353	\$7,728	RC	\$500
14	Miscellaneous Property Scheduled	30xZoom PTZ Camera with HDMI Output and NDI(White) (PIE)		\$15,620	RC	\$500
15	Miscellaneous Property Scheduled	(2) Wheel Lift System, W.L. 30 (RD) @ 5,000 each	S#4296 S#4297	\$11,000	RC	\$500
16	Miscellaneous Property Scheduled	Rifle Shield M3PPXL (PD)	S#0507	\$4,400	RC	\$500
17	Miscellaneous Property Scheduled	Salt Spreader Swenson for T10 (RD)	S#2012-8	\$3,850	RC	\$500
18	Miscellaneous Property Scheduled	Multi-Force Door Simulator (FD)	S#7184	\$6,820	RC	\$500



Additional Property Statement of Values

West Chester Township, Butler County

Effective Date: 12/01/2023

Printed on: 11/09/2023

Location Information N/A

Line	Classification	Description	Serial No	Coverage Limit	Valuation	Deductible
19	Miscellaneous Property Scheduled	Power Pressure Washer, Landa Platinum Series Attached to Trailer (RD)	S#1983 #0884	\$10,995	RC	\$500
20	EDP - Hardware	Leased Copiers per 2023 Inventory, including Software		\$381,645	RC	\$500
21	Miscellaneous Property Scheduled	Thermal Imaging Cameras, MSA 10097331, 4 @ \$9,116 each (FD)	S#0140, S# #0141, S#0142, S#0143	\$40,110	RC	\$500
22	Miscellaneous Property Scheduled	Bush Hog 5' (RD)		\$9,350	RC	\$500
23	Miscellaneous Property Scheduled	Salt Spreader, Snow Ex V-Box for small trucks (RD)	S#TR-00	\$4,400	RC	\$500
24	Miscellaneous Property Scheduled	Mauldin 1450 Roller (RD)	S#1450	\$33,000	RC	\$500
25	Miscellaneous Property Scheduled	(2) Audio Visual Equip: Panasonic Projectors (PD) @ 10,155 each	S#0356 S#0358	\$22,341	RC	\$500
26	Miscellaneous Property Scheduled	(2) Loki Drones @ 5,000 each (PD)	S#0325, 0357	\$11,000	RC	\$500
27	Miscellaneous Property Scheduled	Case 580 SN TLB Backhoe 4WD Loader/Extendahoe (RD)	S#3043	\$154,000	RC	\$500
28	Miscellaneous Property Scheduled	Apple w/23" Display (PIE)		\$8,250	RC	\$500
29	Miscellaneous Property Scheduled	Telex P1400 LCD Projector (PD)	S#0005	\$5,500	RC	\$500
30	Miscellaneous Property Scheduled	(2) Canon Camera's @ 4,000. each (PD)	S#1131, S#1133	\$8,800	RC	\$500
31	Miscellaneous Property Scheduled	Canon L2 Video (PD)	S#0360	\$4,400	RC	\$500
32	Miscellaneous Property Scheduled	Intoxilyzer 5000 EN (PD)	S#3681	\$5,720	RC	\$500
33	Miscellaneous Property Scheduled	Grasshopper Mower 335-B (UCB)	S#5872	\$15,950	RC	\$500
34	Miscellaneous Property Scheduled	Plow, Western, 8'6" for U-7 (RD)	S#TR-U7	\$5,500	RC	\$500
35	Miscellaneous Property Scheduled	(2) Paratech Stabilization Kits @ 8,000 each (FD)		\$17,600	RC	\$500
36	Miscellaneous Property Scheduled	(5) Ram Fan-Electric Fan STA71, STA72; STA73; STA74; STA75 (FD)		\$22,000	RC	\$500



Additional Property Statement of Values

West Chester Township, Butler County

Effective Date: 12/01/2023

Printed on: 11/09/2023

Location Information N/A

Line	Classification	Description	Serial No	Coverage Limit	Valuation	Deductible
37	Miscellaneous Property Scheduled	Alamo Maverick Mowing Arm w/Accessories Attached to & including JD Tractor/Cab (RD)	S#1256 S#6679	\$186,101	RC	\$500
38	Miscellaneous Property Scheduled	(2) Calcium Tank, Ace Roto- Mold 6250 Gal. @ 4,480 each (RD)		\$9,856	RC	\$500
39	Miscellaneous Property Scheduled	Speed Sentry Shield (PD)	S#0123	\$5,627	RC	\$500
40	Miscellaneous Property Scheduled	Mower, Grasshopper 61" Model 335	7317254	\$15,253	RC	\$500
41	Miscellaneous Property Scheduled	Vinten Tripod 1 (PIE)	S#4265	\$7,700	RC	\$500
42	Miscellaneous Property Scheduled	Salt Spreader Swenson V-Box for T20 (RD)	S#2012-11	\$12,942	RC	\$500
43	Miscellaneous Property Scheduled	Gledhill 10SBPR2-OCP-LL-TE Plow T25 (RD)	S#4197	\$11,000	RC	\$500
44	Miscellaneous Property Scheduled	Western 8' Pro Plus Snow Plow (RD)	S#TBD	\$5,374	RC	\$500
45	Miscellaneous Property Scheduled	Tricaster TC1 Base (PIE)		\$21,995	RC	\$500
46	Miscellaneous Property Scheduled	Honda 25hp Outboard Motor (FD)	S#9003	\$8,250	RC	\$500
47	Miscellaneous Property Scheduled	Plow, Gledhill, 10' (RD)	S#2012-3	\$8,800	RC	\$500
48	Miscellaneous Property Scheduled	Gravely Mower (PK)	S#8129	\$4,348	RC	\$500
49	Miscellaneous Property Scheduled	(2) OSTI Magnum Universal Night Sights @ 10,000 each (PD)	S#1683, S#1674	\$22,000	RC	\$500
50	Miscellaneous Property Scheduled	Microfilm Scanner, Canon (CD)	S#456	\$5,480	RC	\$500
51	Miscellaneous Property Scheduled	MPH Industries Trailer (PD)	S#7259	\$5,500	RC	\$500
52	Miscellaneous Property Scheduled	Gledhill Plow for T5 (RD)	S#2012-2	\$6,595	RC	\$500
53	Miscellaneous Property Scheduled	Direct Link - Hostage Throw Phone Tactical Forward Unit (PD)	S#11737	\$27,500	RC	\$500
54	Miscellaneous Property Scheduled	New Holland TC40D Tractor w/Bucket (CEM)	S#5050	\$24,324	RC	\$500



Additional Property Statement of Values

West Chester Township, Butler County

Effective Date: 12/01/2023

Printed on: 11/09/2023

Location Information N/A

Line	Classification	Description	Serial No	Coverage Limit	Valuation	Deductible
55	Miscellaneous Property Scheduled	Plows 2-Western UTPP 9' Steel Pro Plus 2 for U3 U24 @ \$4740 each (RD)	S#6014, S#6015	\$10,428	RC	\$500
56	Miscellaneous Property Scheduled	Patching Machine Duraco M125 on Trailer (RD)	S#2867	\$54,892	RC	\$500
57	Miscellaneous Property Scheduled	Portable TV, Recording & Studio Equipment WCCTV		\$306,075	RC	\$500
58	Miscellaneous Property Scheduled	Salt Spreader, Henderson (RD)		\$4,290	RC	\$500
59	Miscellaneous Property Scheduled	Plotter, Imageprograf iPF 765 (CDD)	S#476	\$9,011	RC	\$500
60	Miscellaneous Property Scheduled	Western Plow 9' Pro Plus for U12 (RD)	S#2012-6	\$5,830	RC	\$500
61	Miscellaneous Property Scheduled	Trailer 5'x8' Easy Dump (CEM)	S#1138	\$3,850	RC	\$500
62	Miscellaneous Property Scheduled	Power Management System, Event (PK)	S#3200	\$11,000	RC	\$500
63	Miscellaneous Property Scheduled	SJ3226 Skyjack Scissor Lift	A101003450	\$20,075	RC	\$500
64	Miscellaneous Property Scheduled	Ultrix New Style 1RU Frame w/16x16 plus 2 aux (PIE)	Ross Video	\$10,345	RC	\$500
65	Miscellaneous Property Scheduled	(2) Salt Spreaders Swenson SBD9 for T8 @ 6,000 & T22 @ 3,545 (RD)	S#6010, S#6011	\$10,500	RC	\$500
66	Miscellaneous Property Scheduled	Fume Hood (PD)	S#0105	\$13,200	RC	\$500
67	Miscellaneous Property Scheduled	1999 Jacobsen HR-9016 Mower (PK)	S#2642	\$61,600	RC	\$500
68	Miscellaneous Property Scheduled	Video Conferencing Equipment (FD)		\$84,700	RC	\$500
69	Miscellaneous Property Scheduled	2023 Darkhorse Trailer (PIE)	S#3263	\$4,615	RC	\$500
70	Miscellaneous Property Scheduled	(2) Magnum Universal Night Sights @ \$10,000 each (PD)	S#674D, S#683D	\$22,000	RC	\$500
71	Miscellaneous Property Scheduled	Skydio SDR21V1 Drone (PD)	S#27T4	\$33,000	RC	\$500
72	Miscellaneous Property Scheduled	(2) Thermal Imagers @ \$6,182. each (PD)	S#5275, S#5262	\$13,600	RC	\$500
73	Miscellaneous Property Scheduled	Betterbuilt Trailer (PK)	S#1159	\$4,400	RC	\$500



Additional Property Statement of Values

West Chester Township, Butler County

Effective Date: 12/01/2023

Printed on: 11/09/2023

Location Information N/A

Line	Classification	Description	Serial No	Coverage Limit	Valuation	Deductible
74	Miscellaneous Property Scheduled	Wacker 4" Trash Pump w/Hoses (RD)	S#TS4V	\$3,869	RC	\$500
75	Miscellaneous Property Scheduled	30' Better Built Trailer (RD)	S#1792	\$9,125	RC	\$500
76	Miscellaneous Property Scheduled	(50) MSA G1 SCBA's @ 13,893 each (FD)		\$764,115	RC	\$500
77	Miscellaneous Property Scheduled	(4) Thermal Imaging Cameras @ \$9,290 each (PD)	S#0222, S#0224, S#0223, S#0225	\$40,876	RC	\$500
78	Miscellaneous Property Scheduled	1995 Pace American Cargo Trailer w/Zodiac Rescue inflatable Boat (FD)	S#0011	\$27,500	RC	\$500
79	Miscellaneous Property Scheduled	Grasshopper 723T2 Mower (CEM)	S#5099	\$13,200	RC	\$500
80	Miscellaneous Property Scheduled	2005 Komatsu FG225T-14 Forklift (RD)	S#660A	\$33,000	RC	\$500
81	Miscellaneous Property Scheduled	(2) Exmark 60" Laser Z Mowers @ \$7,599 each (PK)	S#6583, S#6580	\$16,718	RC	\$500
82	Miscellaneous Property Scheduled	Hazard House Fire Simulator (FD)	S#181A	\$16,500	RC	\$500
83	Miscellaneous Property Scheduled	Hostage Negotiator Throw Phone (PD)	S#0003	\$26,730	RC	\$500
84	Miscellaneous Property Scheduled	Vinten Tripod 3 (PIE)	S#4231	\$7,700	RC	\$500
85	Miscellaneous Property Scheduled	Miscellaneous Telephone Equipment (Misc. Depts)		\$361,383	RC	\$500
86	Miscellaneous Property Scheduled	OpticalCon Duo SMPTE Assy SM - 4 - 305 ft rrels (PIE)		\$6,089	RC	\$500
87	Miscellaneous Property Scheduled	Leg Press, Linear: Hammer Strength (PD)	S#1440	\$3,850	RC	\$500
88	Miscellaneous Property Scheduled	Grasshopper Mower Model 729BT T6 61" (CEM)	S#29BT	\$13,200	RC	\$500
89	Miscellaneous Property Scheduled	(7) Flir K65 Thermal Imaging Cameras @ \$5,239 each (FD)	S#2010 S#1980 S#2004 S#1994 S#2009 S#1985 S#1999	\$40,340	RC	\$500
90	Miscellaneous Property Scheduled	Crack Sealer Magma Cimline, M#150 DHC (Mi) Melter Applicator (on 2-wheel trailer) (RD)	S#9089	\$57,002	RC	\$500



Additional Property Statement of Values

West Chester Township, Butler County

Effective Date: 12/01/2023

Printed on: 11/09/2023

Location Information N/A

Line	Classification	Description	Serial No	Coverage Limit	Valuation	Deductible
91	Miscellaneous Property Scheduled	Plow, Western, 9', Pro Guard for U-8 (RD)	S#0655	\$5,500	RC	\$500
92	Miscellaneous Property Scheduled	Intoxilyzer 8000	80-004373	\$15,000	RC	\$500
93	Miscellaneous Property Scheduled	Sokkia Total Station (RD)	S#9946	\$11,660	RC	\$500
94	Miscellaneous Property Scheduled	10' Gledhill Snow Plow for T18 (RD)	S#6005	\$5,450	RC	\$500
95	Miscellaneous Property Scheduled	Castus Box (PIE)		\$30,800	RC	\$500
96	Miscellaneous Property Scheduled	Geomax CR5 Total Station, Prism, Tablet	951078, 13955, 251360	\$30,000	RC	\$500
97	Miscellaneous Property Scheduled	Thermal Imaging Camera w/2 Lithium Ion Batteries (FD)	S#3764	\$10,013	RC	\$500
98	Miscellaneous Property Scheduled	(2) Portable Light Towers @ \$7,539 each (SERVICE)	S#0278, S#0279	\$16,586	RC	\$500
99	Miscellaneous Property Scheduled	Bobcat S220 Skid Loader (RD)	S#6001	\$44,000	RC	\$500
100	Miscellaneous Property Scheduled	Battery Operated Hydraulic Spreader (FD)		\$14,236	RC	\$500
101	Miscellaneous Property Scheduled	Stormpipe Camera System telescopic w/case, Quick View North American Professional 24 (RD)	S#4512	\$18,211	RC	\$500
102	Miscellaneous Property Scheduled	Plow, Gledhill, 10' for 23 (RD)	S#TR-23	\$5,500	RC	\$500
103	Miscellaneous Property Scheduled	Salt Spreader for U-8 (RD)	S#TR-U8	\$3,900	RC	\$500
104	Miscellaneous Property Scheduled	Thermal Imaging Camera MSA 10097331 (FD)	S#0361	\$7,150	RC	\$500
105	Miscellaneous Property Scheduled	Panasonic Hand Held Video Camera (PIE)		\$6,050	RC	\$500
106	Miscellaneous Property Scheduled	Hunter TC3250 Tire Changer w/Wheel Lift (RD)	S#4470	\$7,748	RC	\$500
107	Miscellaneous Property Scheduled	(4) LifePak Defibrillators @ 30,500 each (FD)		\$134,200	RC	\$500
108	Miscellaneous Property Scheduled	(2) Elliptical: Precor @ 4,500 each (PD)	S#1438 S#1439	\$9,900	RC	\$500



Additional Property Statement of Values

West Chester Township, Butler County

Effective Date: 12/01/2023

Printed on: 11/09/2023

Location Information N/A

Line	Classification	Description	Serial No	Coverage Limit	Valuation	Deductible
109	Miscellaneous Property Scheduled	Crack Sealer 2007 Cimline 110 Gal DHC Melter Part on 2 Wheel Trailer (RD)	S#9117	\$57,002	RC	\$500
110	Miscellaneous Property Scheduled	Tricaster 2 Elite (3RU Chassis with redundant power) (PIE)	Newtek FG-002932 -R001	\$29,995	RC	\$500
111	Miscellaneous Property Scheduled	Mower, Grasshopper 720K RoboMower (RD)	S#5063	\$13,200	RC	\$500
112	Miscellaneous Property Scheduled	1998 Betterbuilt Car Hauler Trailer (PD)	S#1155	\$8,250	RC	\$500
113	Miscellaneous Property Scheduled	(2) Speed Sentry Signs (PD) @ 4,665 each	S#0125 S#0126	\$10,263	RC	\$500
114	Miscellaneous Property Scheduled	Bosch A/C Refrigerant Handling System (RD)	S#4560	\$4,950	RC	\$500
115	Miscellaneous Property Scheduled	(3) Treadmills - Life Fitness (PD) @ 4,050 each	S#6572, S#6567 & S#7403	\$13,365	RC	\$500
116	Miscellaneous Property Scheduled	Genesis Battery Operated Hydraulic Cutter (FD)		\$13,992	RC	\$500
117	Miscellaneous Property Scheduled	Salt Spreader Swenson PU358EST V-Box for U24 (RD)	S#6017	\$3,850	RC	\$500
118	Miscellaneous Property Scheduled	Sullair Air Compressor (RD)	S#4338	\$16,500	RC	\$500
119	Miscellaneous Property Scheduled	Ibak Pipe Crawler Camera		\$91,024	RC	\$500
120	EDP - Hardware	Blanket EDP per 2023 Inventory, including Software		\$1,543,313	RC	\$500
121	Miscellaneous Property Scheduled	(3) Automatic License Plate Readers @ 7,500 each (PD)	S#0003, S#0004, S#0005	\$24,750	RC	\$500
122	Miscellaneous Property Scheduled	Tarot 680 Drone (PIE)		\$5,500	RC	\$500
123	Miscellaneous Property Scheduled	2019 Sure-Trac Utility Trailer (RD)	S#6716	\$3,746	RC	\$500
124	Miscellaneous Property Scheduled	Emergency Response Trailer w/Equipment (RD)	S#4613	\$27,437	RC	\$500
125	Miscellaneous Property Scheduled	2021 Polaris Ranger XP1000 (Police)	S#4080	\$22,000	RC	\$500
126	Miscellaneous Property Scheduled	Plow, Western 10' Pro Guard for T20 (RD)	S#2012-1	\$9,020	RC	\$500
127	Miscellaneous Property Scheduled	Fitness Treadmill (RD)	S# TBD	\$4,400	RC	\$500



Additional Property Statement of Values

West Chester Township, Butler County

Effective Date: 12/01/2023

Printed on: 11/09/2023

Location Information N/A

Line	Classification	Description	Serial No	Coverage Limit	Valuation	Deductible
128	Miscellaneous Property Scheduled	2022 Kubota Flail Mower Tractor (Service)	S#7810	\$83,102	RC	\$500
129	Miscellaneous Property Scheduled	Smith Hazmat Gas Detection I.D. Kit (FD)	S#9001	\$68,200	RC	\$500
130	Miscellaneous Property Scheduled	(2) TSU Speed Sentry Signs @ 4,665 each (PD)	S#0125, 0136	\$10,263	RC	\$500
131	Miscellaneous Property Scheduled	Sports Arc Fitness Treadmill/7670E (FD)		\$4,395	RC	\$500
132	Miscellaneous Property Scheduled	Plow, Western for U-13 (RD)	S#TR-U13	\$5,500	RC	\$500
133	Miscellaneous Property Scheduled	800 MHz Radio System per 2023 Inventory (All)		\$1,531,819	RC	\$500
134	Miscellaneous Property Scheduled	2019 Grasshopper Model #335 993C Big Block 72" Mower (RD)		\$12,181	RC	\$500
135	Miscellaneous Property Scheduled	Plow, Gledhill, 10' Power Angle for 12 (RD)	S#4139	\$5,500	RC	\$500
136	Miscellaneous Property Scheduled	Gledhill 10SBPCL 10' Plow w/Hitch for T22 (RD)	S#6012	\$9,658	RC	\$500
137	Miscellaneous Property Scheduled	Cellebrite UFED Touch (PD)	S#0108	\$10,560	RC	\$500
138	Miscellaneous Property Scheduled	Salt Spreader for 23 (RD)	S#TR-23	\$6,600	RC	\$500
139	Miscellaneous Property Scheduled	Mower Grasshopper 335B 61" (CEM)	S#1913	\$13,750	RC	\$500
140	Miscellaneous Property Scheduled	Salt Spreader, Monroe Box for 15 (RD)	S#TR-15	\$4,400	RC	\$500
141	Miscellaneous Property Scheduled	(4) Ozen Tripods @ 4,000 each (PIE)		\$17,600	RC	\$500
142	Miscellaneous Property Scheduled	Hood (PD)	S#6AAA	\$13,200	RC	\$500
143	Miscellaneous Property Scheduled	Verisight Pro push camera	CVP-0640	\$9,754	RC	\$500
144	Miscellaneous Property Scheduled	Verisight Pro Push Camera (RD)	S#0640	\$10,729	RC	\$500
145	Miscellaneous Property Scheduled	Hunter DSP 9112 W Wheel Balancer (RD)	S#4469	\$6,820	RC	\$500
146	Miscellaneous Property Scheduled	Berm Box Swenson Tailgate Conveyor (RD)		\$5,828	RC	\$500



Additional Property Statement of Values

West Chester Township, Butler County

Effective Date: 12/01/2023

Printed on: 11/09/2023

Location Information N/A

Line	Classification	Description	Serial No	Coverage Limit	Valuation	Deductible
147	Miscellaneous Property Scheduled	Beckett Park Pond Aerator (PK)	S#3051	\$15,374	RC	\$500
148	Miscellaneous Property Scheduled	Swenson Cross Conveyor Berm Spreader for T19 (RD)	S#STCC	\$5,828	RC	\$500
149	Miscellaneous Property Unscheduled	Unscheduled Miscellaneous Property-Limit per occurrence, \$5,000 maximum limit per any one item		\$2,073,879	RC	\$500
150	Miscellaneous Property Scheduled	(2) Speed Sentry Shields w/PDA @ \$5,515 each (PD)	S#0124, S#0122	\$12,133	RC	\$500
151	Miscellaneous Property Scheduled	(2) 2000 Polaris Sportsman ATV's @ \$11,700 each (PD)	S#7979, S#7530	\$25,740	RC	\$500
152	Miscellaneous Property Scheduled	(4) Lift Rotary 4 Column 18,000 lb Portable 24V DC Wireless Model @ 9,339 each (CEM)	S#0037 S#0038 S#0039 S#0040	\$41,092	RC	\$500
153	Miscellaneous Property Scheduled	Thermal Imaging Camera MSA (FD)	S#0080	\$10,010	RC	\$500
154	Miscellaneous Property Scheduled	Plow, Meyer for U-6 (RD)	S#TR-U6	\$5,500	RC	\$500
155	Miscellaneous Property Scheduled	Stormpipe Quickview Air HD System Camera (RD)	S#0365	\$16,817	RC	\$500
156	Miscellaneous Property Scheduled	Vinten Tripod (PIE)		\$10,120	RC	\$500
157	Miscellaneous Property Scheduled	Fire Extinguisher Simulator Training System (FD)	S#0256	\$9,535	RC	\$500
158	Miscellaneous Property Scheduled	2023 Bobcat E42 R2 Excavator (Serv)	S#7035	\$77,193	RC	\$500
159	Miscellaneous Property Scheduled	Down Draft Hood (PD)	S#0205	\$13,200	RC	\$500
160	Miscellaneous Property Scheduled	Genesis Battery Operated Ram (FD)		\$11,380	RC	\$500
161	Miscellaneous Property Scheduled	Gledhill 10SBP R2-TE Snow Plow for T8 (RD)	S#1009	\$8,949	RC	\$500
162	Miscellaneous Property Scheduled	(2) Plexus Seating Units (PD) @ 5,350 each	S#0213 S#0214	\$11,770	RC	\$500
163	Miscellaneous Property Scheduled	(2) Rescue CRT Model Phone w/ Headsets @ 5,300 each (PD)	S#1217 S# TBD	\$11,660	RC	\$500



Additional Property Statement of Values

West Chester Township, Butler County

Effective Date: 12/01/2023

Printed on: 11/09/2023

Location Information N/A

Line	Classification	Description	Serial No	Coverage Limit	Valuation	Deductible
164	Miscellaneous Property Scheduled	Bobcat E35ZTS Compact Excavator (CEM)	S#1078	\$57,200	RC	\$500
165	Miscellaneous Property Scheduled	24' Better Built 12 T Trailer (RD)	S#1690	\$7,502	RC	\$500
166	Miscellaneous Property Scheduled	Air Monitoring System Controllers & Monitors (FD)	S#2268	\$66,000	RC	\$500
167	Miscellaneous Property Scheduled	Gledhill 10SBP CL 10' Snow Plow for T21 (RD)	S#6008	\$7,920	RC	\$500
168	Miscellaneous Property Scheduled	Tactical Repeater System (PD)	S#3048	\$5,947	RC	\$500
169	Miscellaneous Property Scheduled	Speed Sentry Sheild w/PDA (PD)	S#0121	\$5,627	RC	\$500
170	Miscellaneous Property Scheduled	Salt Spreader Swenson PU358EST V-Box for U3 (RD)	S#6016	\$5,214	RC	\$500
171	Miscellaneous Property Scheduled	Bobcat 4x4 UTV M#3650 w/70" Angle Broom	S#8300, S#1219	\$30,150	RC	\$500
172	Miscellaneous Property Scheduled	Genesis S49XL Spreader (FD)	S#0352	\$6,765	RC	\$500
173	Miscellaneous Property Scheduled	ALS (PD)	S#0558	\$13,200	RC	\$500
174	Miscellaneous Property Scheduled	(21) Motorola APX Mobile Radios @ 4,240 each (FD)		\$97,944	RC	\$500
175	Miscellaneous Property Scheduled	(2) Oceanid RDC Swiftwater Rescue Boat (FD)		\$10,780	RC	\$500
176	Miscellaneous Property Scheduled	Vehicle Barricade System		\$178,489	RC	\$500
177	Miscellaneous Property Scheduled	Blanket Integrated Multimedia & Marketing Property - Per 2018 list on File (IT)		\$1,067,660	RC	\$500
178	Miscellaneous Property Scheduled	Scrubber/Rider M7400 (RD)	S#4406	\$55,000	RC	\$500
179	Miscellaneous Property Scheduled	Bosch, Divar 700 Interview Equipment (PD)	S#0135	\$6,863	RC	\$500
180	Miscellaneous Property Scheduled	Western Plow U-23 (Rd)	S#2012-5	\$5,500	RC	\$500
181	Miscellaneous Property Scheduled	Salt Spreader Warren Box U-27 (RD)	S#U-27	\$4,950	RC	\$500
182	Miscellaneous Property Scheduled	Genesis M-3 Outlaw Pumper (FD)	S#0351	\$7,051	RC	\$500



Additional Property Statement of Values

West Chester Township, Butler County

Effective Date: 12/01/2023

Printed on: 11/09/2023

Location Information N/A

Line	Classification	Description	Serial No	Coverage Limit	Valuation	Deductible
183	Miscellaneous Property Scheduled	Salt Spreader Swenson T25 (RD)	S#TR25	\$5,500	RC	\$500
184	Miscellaneous Property Scheduled	Genesis Hydraulic Rams (FD)		\$8,104	RC	\$500
185	Miscellaneous Property Scheduled	(3) Plows @ \$6,000 each for T7 T19 T13 (RD)	S#6002-1, S#6003-1, S#6004-1	\$19,800	RC	\$500
186	Miscellaneous Property Scheduled	Salt Spreader Swenson V Box for T12 (RD)	S#2012-9	\$6,600	RC	\$500
187	Miscellaneous Property Scheduled	Walkaround Inflatable Fireman (FD)	S#1053	\$4,400	RC	\$500
188	Miscellaneous Property Scheduled	2014 Redi Haul Tilt Bed Trailer (Serv)	S#6969	\$2,145	RC	\$500
189	Miscellaneous Property Scheduled	Intoxilyzer 5000 (PD)	S#1958	\$5,500	RC	\$500
190	Miscellaneous Property Scheduled	Patches & Pumper Remote Control Unit (FD)	S#6003	\$9,770	RC	\$500
191	Miscellaneous Property Scheduled	(2) Batshields: Full Sized @ \$6,000 each (PD)	S#001F-1, S#001F-2	\$13,200	RC	\$500
192	Miscellaneous Property Scheduled	Bobcat T770 T4 Compact Track Loader w/ Hydraulic breaker & Snow Blade	S#2626	\$105,824	RC	\$500
193	Miscellaneous Property Scheduled	Grasshopper Mower Model 335-72-35 (UCB)	S#0226	\$11,935	RC	\$500
194	Miscellaneous Property Scheduled	(3) Swenson Spreaders @ \$6,000 each for T19 T7 T13 (RD)	S#6002-2, S#6003-2, S#6004-2	\$19,800	RC	\$500
195	Miscellaneous Property Scheduled	Gledhill 10' Plow for T10 (RD)	S#2012-3	\$10,450	RC	\$500
196	Miscellaneous Property Scheduled	GPS Trimble GEO 7X (IT)	S#3552	\$9,984	RC	\$500
197	Miscellaneous Property Scheduled	2000 R & W Trailer (Pk)	S#9285	\$3,850	RC	\$500
198	Miscellaneous Property Scheduled	2002 Jacobsen HR 9016 Mower (PK)	S#3035	\$74,049	RC	\$500
199	Miscellaneous Property Scheduled	Exmark 60" Mower w/ Mulch Kit (PK)	S#C604	\$9,222	RC	\$500
200	Miscellaneous Property Scheduled	Vermeer 18" Chipper (RD)	S#4339	\$66,000	RC	\$500
201	Miscellaneous Property Scheduled	(3) High Density Filing System (PD) @ 83,000 each	S#0209 S#0672 S#0673	\$273,900	RC	\$500



Additional Property Statement of Values

West Chester Township, Butler County

Effective Date: 12/01/2023

Printed on: 11/09/2023

Location Information N/A

Line	Classification	Description	Serial No	Coverage Limit	Valuation	Deductible
202	Miscellaneous Property Scheduled	(2) Batshields: Compact @ \$5,800 each (PD)	S#0010-1, S#0010-2	\$12,760	RC	\$500
203	Miscellaneous Property Scheduled	2005 Task Force DUI Trailer (PD)	S#7351	\$3,878	RC	\$500
204	Miscellaneous Property Scheduled	(14) Lifepak 1000 AED's, (6) Lifepak 15 monitors & (18) Batteries (FD)		\$242,000	RC	\$500
205	Miscellaneous Property Scheduled	(56) Motorola APX 6000XE Portable Radios @ 6,996 each (FD)		\$430,954	RC	\$500
206	Miscellaneous Property Scheduled	Swenson Stainless Steel Salt Spreader for T24 (RD)	S#T24S	\$3,850	RC	\$500
207	Miscellaneous Property Scheduled	(4) Sony HXC-FB80 Cameras @ 18,495 each (PIE)	S#1103, 1100, 1094 & 1090	\$81,378	RC	\$500
208	Miscellaneous Property Scheduled	Gator 4 USB Pipe Camera System (RD)	S#0058	\$9,456	RC	\$500

Total EDP - Hardware	\$1,924,958
Total Miscellaneous Property Scheduled	\$9,177,371
Total Miscellaneous Property Unscheduled	\$2,073,879
Total Location Additional Property Scheduled Value	\$13,176,208

Grand Total EDP - Hardware	\$1,924,958
Grand Total Miscellaneous Property Scheduled	\$9,177,371
Grand Total Miscellaneous Property Unscheduled	\$2,073,879
Grand Total Additional Property Scheduled Value	\$13,176,208



Schedule of Covered Vehicles

**West Chester Township,
Butler County**

Effective Date: 12/01/2023

Printed on: 11/09/2023

#	Year	Make	Model	VIN	Type	Value	Valuation Comp	Ded	Coll	Ded
1	2008	Jeep	Cherokee (Police)	S#9558	Police	23,298	ACV Y	\$500	Y	\$500
2	2007	Freightliner	SWAT Police	S#9726	Extra Heavy	300,000	RC Y	\$500	Y	\$500
3	2008	Dodge	Dakota Pick Up (Police)	S#1725	Police	19,395	ACV Y	\$500	Y	\$500
4	1996	Ford	F350 1 T Dump Truck (Rd.)	S#7328	Dump Trucks	19,000	ACV Y	\$500	Y	\$500
5	2000	Ford	F350 Dump Truck (Rd.)	S#8351	Dump Trucks	34,726	ACV Y	\$500	Y	\$500
6	2003	Ford	F350 Dump Truck (UCB)	S#5272	Dump Trucks	24,824	ACV Y	\$500	Y	\$500
7	2011	Ford	F450 Dump Truck (Parks)	S#0653	Dump Trucks	35,893	ACV Y	\$500	Y	\$500
8	2008	Dodge	Ram 1 Ton Dump (Parks)	S#7935	Dump Trucks	26,162	ACV Y	\$500	Y	\$500
9	2008	Chevrolet	7500 Dump Truck (Rd.)	S#8185	Dump Trucks	50,143	ACV Y	\$500	Y	\$500
10	2009	Chevrolet	C-7500 Dump Truck (Rds)	S#0246	Dump Trucks	44,953	ACV Y	\$500	Y	\$500



Schedule of Covered Vehicles

**West Chester Township,
Butler County**

Effective Date: 12/01/2023

Printed on: 11/09/2023

11	1994	Chevrolet	Kodiak Hazmat	S#0552	Fire Trucks	890,000	RC	Y	\$500	Y	\$500
12	2010	International	Horton 603C-1 Ambulance Medic 73	S#4292	Ambulances	430,000	RC	Y	\$500	Y	\$500
13	2006	Horton	Service Truck (Rd)	S#5869	Lt. Med Trucks	25,000	ACV	Y	\$500	Y	\$500
14	1999	GMC	2 1/2 Ton Dump Truck (Rd.)	S#1497	Dump Trucks	34,986	ACV	Y	\$500	Y	\$500
15	2008	Ford	Crown Victoria Police Car	S#9017	Police	20,080	ACV	Y	\$500	Y	\$500
16	2010	Ford	Crown Victoria Police Car	S#3871	Police	40,207	ACV	Y	\$500	Y	\$500
17	2008	Ford	Econo Cutaway (Police)	S#9878	Police	54,500	ACV	Y	\$500	Y	\$500
18	2008	Ford	Escape Police Car	S#5112	Police	16,891	ACV	Y	\$500	Y	\$500
19	2003	International	2.5T Dump Truck (Rd)	S#6770	Dump Trucks	75,000	ACV	Y	\$500	Y	\$500
20	2010	International	4400 2.5 Ton Dump Truck (Rd.)	S#2660	Dump Trucks	94,600	ACV	Y	\$500	Y	\$500
21	2009	International	4400 2.5T Dump Truck (Rd.)	S#4040	Dump Trucks	82,563	ACV	Y	\$500	Y	\$500
22	2007	International	4400 2.5T Dump Truck(Rd)	S#3553	Dump Trucks	69,537	ACV	Y	\$500	Y	\$500



Schedule of Covered Vehicles

**West Chester Township,
Butler County**

Effective Date: 12/01/2023

Printed on: 11/09/2023

23	2001	International	4900 Dump Truck (Rd.)	S#0491	Dump Trucks	87,000	ACV	Y	\$500	Y	\$500
24	2005	International	7400 Dump Truck (Rd)	S#8092	Dump Trucks	86,064	ACV	Y	\$500	Y	\$500
25	2004	International	Dump Truck (Rd.)	S#3291	Dump Trucks	77,836	ACV	Y	\$500	Y	\$500
26	2014	International	4400 Dump w/Plow & Spreader (Rd.)	S#7163	Dump Trucks	117,665	ACV	Y	\$500	Y	\$500
27	2001	International	2.5 Ton Dump Truck (Rd.)	S#0492	Dump Trucks	87,000	ACV	Y	\$500	Y	\$500
28	2002	International	2.5 Ton Dump Truck (Rd.)	S#7415	Dump Trucks	47,793	ACV	Y	\$500	Y	\$500
29	2010	Sutphen	100' Aerial Ladder Truck w/ Equipment Tower 73	S#3073	Fire Trucks	1,850,000	RC	Y	\$500	Y	\$500
30	2011	Sutphen	75' Quint Aerial Ladder Reserve	S#3001	Fire Trucks	1,500,000	RC	Y	\$500	Y	\$500
31	2009	Sutphen	Pumper Engine 78	S#3097	Fire Trucks	750,000	RC	Y	\$500	Y	\$500
32	2001	Ford	TV Rem Van (WCCTV) EXCLUDING EQUIPMENT	S#5790	Lt. Med Trucks	60,000	ACV	Y	\$500	Y	\$500
33	2005	Chevrolet	Silverado HD Pick Up (Rd)	S#4903	Passenger Car/Vans/Pickups	23,761	ACV	Y	\$500	Y	\$500



Schedule of Covered Vehicles

**West Chester Township,
Butler County**

Effective Date: 12/01/2023

Printed on: 11/09/2023

34	2002	Dodge	Ram 2500 Pick Up (Rd.)	S#9352	Passenger Car/Vans/Pickups	24,494	ACV	Y	\$500	Y	\$500
35	2002	Dodge	Ram 3500 Pick Up (Cem)	S#9050	Passenger Car/Vans/Pickups	24,000	ACV	Y	\$500	Y	\$500
36	1996	Dodge	Ram 4x4 Brush Truck 71	S#8769	Fire Trucks	90,000	RC	Y	\$500	Y	\$500
37	2008	Dodge	Ram Pick Up (Rd.)	S#8016	Passenger Car/Vans/Pickups	19,769	ACV	Y	\$500	Y	\$500
38	2009	Ford	Expedition Fire Car	S#1047	Passenger Car/Vans/Pickups	35,960	ACV	Y	\$500	Y	\$500
39	2010	Ford	Expedition Fire Car	S#0944	Passenger Car/Vans/Pickups	35,960	ACV	Y	\$500	Y	\$500
40	2012	Ford	Expedition Fire Car w/Equipment	S#5707	Passenger Car/Vans/Pickups	39,679	ACV	Y	\$500	Y	\$500
41	2009	Ford	Explorer (CDD)	S#6251	Passenger Car/Vans/Pickups	23,922	ACV	Y	\$500	Y	\$500
42	2003	Ford	F150 Pick Up (SV)	S#4929	Passenger Car/Vans/Pickups	11,376	ACV	Y	\$500	Y	\$500
43	2004	Ford	F250 SRW SD Pick Up (UCB)	S#7031	Passenger Car/Vans/Pickups	23,855	ACV	Y	\$500	Y	\$500
44	2009	Ford	F350 Flatbed Truck w/Hitch (Rd.)	S#5742	Lt. Med Trucks	25,078	ACV	Y	\$500	Y	\$500
45	2009	Ford	F350 Flatbed Truck (Rd.)	S#5743	Lt. Med Trucks	27,804	ACV	Y	\$500	Y	\$500



Schedule of Covered Vehicles

**West Chester Township,
Butler County**

Effective Date: 12/01/2023

Printed on: 11/09/2023

46	2014	Ford	F350 SRW Super Duty Pick Up (Rd)	S#2694	Passenger Car/Vans/Pickups	24,558	ACV	Y	\$500	Y	\$500
47	2003	Ford	F350 Truck (Rd.)	S#5273	Lt. Med Trucks	24,824	ACV	Y	\$500	Y	\$500
48	2012	Ford	Fusion SE Fire Inspector Car w/Attached Equipment	S#0580	Passenger Car/Vans/Pickups	28,440	ACV	Y	\$500	Y	\$500
49	2004	Ford	SRW Super Duty Pick Up (Rd)	S#7032	Passenger Car/Vans/Pickups	32,200	ACV	Y	\$500	Y	\$500
50	2009	GMC	Sierra Pick Up (Rd.)	S#7989	Passenger Car/Vans/Pickups	21,647	ACV	Y	\$500	Y	\$500
51	2007	International	4300 Command Platform Police Vehicle w/Equipment	S#1326	Extra Heavy	350,000	RC	Y	\$500	Y	\$500
52	2012	Freightliner	M2 Dump Truck (Rd.)	S#3398	Dump Trucks	83,124	ACV	Y	\$500	Y	\$500
53	2015	Ford	Police Interceptor SUV	S#7267	Police	40,000	ACV	Y	\$500	Y	\$500
54	2015	Ford	Police Interceptor SUV	S#7269	Police	40,000	ACV	Y	\$500	Y	\$500
55	2015	Ford	Police Interceptor SUV	S#7271	Police	40,000	ACV	Y	\$500	Y	\$500
56	2015	Ford	F350 Dump Truck (Rd)	S#3971	Dump Trucks	51,916	ACV	Y	\$500	Y	\$500



Schedule of Covered Vehicles

**West Chester Township,
Butler County**

Effective Date: 12/01/2023

Printed on: 11/09/2023

57	2016	International	2 1/2 Ton Dump Truck Model 4400 (Rd)	S#0999	Dump Trucks	83,330	ACV	Y	\$500	Y	\$500
58	2016	Ford	Explorer Police Car	S#8274	Police	26,314	ACV	Y	\$500	Y	\$500
59	2016	Ford	Police Interceptor Utility Vehicle	S#8276	Police	25,766	ACV	Y	\$500	Y	\$500
60	2016	Ford	Police Interceptor Utility Vehicle	S#8275	Police	25,766	ACV	Y	\$500	Y	\$500
61	2015	International	4300 Horton Ambulance Reserve	S#0807	Ambulances	430,000	RC	Y	\$500	Y	\$500
62	2016	Ford	Ford Fusion Police	S#0680	Police	17,022	ACV	Y	\$500	Y	\$500
63	2016	Ford	Ford Fusion Police	S#0681	Police	17,022	ACV	Y	\$500	Y	\$500
64	2015	E-One	ISX-450 Pumper	S#9516	Fire Trucks	850,000	RC	Y	\$500	Y	\$500
65	2016	International	4300 Horton Ambulance Medic 74	S#9612	Ambulances	430,000	RC	Y	\$500	Y	\$500
66	2017	Ford	Fusion (Police)	S#8346	Police	18,983	ACV	Y	\$500	Y	\$500
67	2017	Ford	Fusion (Police)	S#8345	Police	18,983	ACV	Y	\$500	Y	\$500
68	2016	Dodge	Caravan (PD)	S#9528	Passenger Car/Vans/Pickups	22,558	ACV	Y	\$500	Y	\$500



Schedule of Covered Vehicles

**West Chester Township,
Butler County**

Effective Date: 12/01/2023

Printed on: 11/09/2023

69	2017	Ford	Police Interceptor Utility Vehicle	S#4233	Police	26,743	ACV	Y	\$500	Y	\$500
70	2017	Ford	Police Interceptor Utility Vehicle	S#4235	Police	26,743	ACV	Y	\$500	Y	\$500
71	2017	Ford	Police Interceptor Utility Vehicle	S#4231	Police	26,743	ACV	Y	\$500	Y	\$500
72	2017	Ford	Police Interceptor Utility Vehicle	S#4234	Police	26,743	ACV	Y	\$500	Y	\$500
73	2017	Ford	Police Interceptor Utility Vehicle	S#4232	Police	26,743	ACV	Y	\$500	Y	\$500
74	2017	Ford	Police Interceptor Utility Vehicle	S#4230	Police	26,743	ACV	Y	\$500	Y	\$500
75	2017	Ford	Police Interceptor Utility Vehicle	S#4229	Police	26,743	ACV	Y	\$500	Y	\$500
76	2017	Ford	Police Interceptor Utility Vehicle	S#4228	Police	26,743	ACV	Y	\$500	Y	\$500
77	2017	Ford	Explorer (Police)	S#4226	Police	27,188	ACV	Y	\$500	Y	\$500
78	2017	Ford	Explorer (Police)	S#4227	Police	27,188	ACV	Y	\$500	Y	\$500
79	2016	Ford	F350 Pickup (Road)	S#2736	Passenger Car/Vans/Pickups	24,894	ACV	Y	\$500	Y	\$500
80	2017	Ford	F550 Medic 72	S#2130	Ambulances	430,000	RC	Y	\$500	Y	\$500



Schedule of Covered Vehicles

**West Chester Township,
Butler County**

Effective Date: 12/01/2023

Printed on: 11/09/2023

81	2018	Freightliner	M2-106 Truck (RD)	S#6824	Lt. Med Trucks	75,982	ACV	Y	\$500	Y	\$500
82	2018	Ford	Explorer Fire Chief Car w/Attached Equipment	S#0771	Passenger Car/Vans/Pickups	41,890	ACV	Y	\$500	Y	\$500
83	2017	Ford	Explorer (PD)	S#5665	Passenger Car/Vans/Pickups	32,000	ACV	Y	\$500	Y	\$500
84	2018	Ford	Explorer (Admin)	S#9719	Passenger Car/Vans/Pickups	26,854	ACV	Y	\$500	Y	\$500
85	2016	Ford	Explorer (Service)	S#1595	Passenger Car/Vans/Pickups	26,000	ACV	Y	\$500	Y	\$500
86	2015	Chevrolet	Malibu Police Car	S#6795	Police	20,000	ACV	Y	\$500	Y	\$500
87	2019	Ford	F350 Pickup w/Dump Bed (Rd)	S#2943	Passenger Car/Vans/Pickups	47,481	ACV	Y	\$500	Y	\$500
88	2019	GMC	Sierra 1500 Pickup w/Strobe Light & Tool Box (Rd)	S#3420	Passenger Car/Vans/Pickups	29,700	ACV	Y	\$500	Y	\$500
89	2018	Ford	Explorer Police Car	S#0764	Police	50,150	ACV	Y	\$500	Y	\$500
90	2018	Ford	Explorer Police Car	S#0765	Police	50,150	ACV	Y	\$500	Y	\$500
91	2018	Ford	Explorer Police Car	S#0766	Police	50,150	ACV	Y	\$500	Y	\$500
92	2018	Ford	Explorer Police Car	S#0768	Police	50,150	ACV	Y	\$500	Y	\$500



Schedule of Covered Vehicles

**West Chester Township,
Butler County**

Effective Date: 12/01/2023

Printed on: 11/09/2023

93	2018	Ford	Explorer Police Car	S#0769	Police	50,150	ACV	Y	\$500	Y	\$500
94	2019	Freightliner	M2-106 Dump Truck (RD)	S#4477	Dump Trucks	139,261	ACV	Y	\$500	Y	\$500
95	2018	Ford	Transit Van (RD)	S#6822	Passenger Car/Vans/Pickups	43,377	ACV	Y	\$500	Y	\$500
96	2018	E-One	Quint Cyclone Fire Truck	S#1752	Fire Trucks	1,500,000	RC	Y	\$500	Y	\$500
97	2018	Ford	Explorer Interceptor Police Car	S#4959	Police	53,490	ACV	Y	\$500	Y	\$500
98	2018	Ford	Explorer Interceptor Police Car	S#4962	Police	53,490	ACV	Y	\$500	Y	\$500
99	2018	Ford	Edge Police Vehicle	S#9031	Police	25,994	ACV	Y	\$500	Y	\$500
100	2018	Ford	Explorer Interceptor Police Car	S#5956	Police	53,490	ACV	Y	\$500	Y	\$500
101	2018	Ford	Transit Connect Van Police Vehicle	S#4672	Police	21,998	ACV	Y	\$500	Y	\$500
102	2018	Ford	Explorer Interceptor Police Car	S#4960	Police	53,490	ACV	Y	\$500	Y	\$500
103	2019	Chevrolet	Tahoe Fire Battalion Car w/Attached Equipment	S#7208	Passenger Car/Vans/Pickups	46,185	ACV	Y	\$500	Y	\$500
104	2018	Ford	Explorer Interceptor Police Car	S#5941	Police	53,490	ACV	Y	\$500	Y	\$500



Schedule of Covered Vehicles

**West Chester Township,
Butler County**

Effective Date: 12/01/2023

Printed on: 11/09/2023

105	2018	Ford	Explorer Interceptor Police Car	S#5978	Police	53,490	ACV	Y	\$500	Y	\$500
106	2019	Ford	F550 Horton Ambulance Medic 75	S#0962	Ambulances	430,000	RC	Y	\$500	Y	\$500
107	2019	GMC	Sierra Limited (RD)	S#7366	Passenger Car/Vans/Pickups	29,018	ACV	Y	\$500	Y	\$500
108	2019	Chevrolet	Tahoe Fire Chief 71 Car w/Attached Equipment	S#0588	Passenger Car/Vans/Pickups	46,770	ACV	Y	\$500	Y	\$500
109	2019	GMC	Sierra Limited (RD)	S#6649	Passenger Car/Vans/Pickups	29,018	ACV	Y	\$500	Y	\$500
110	2018	E-One	Typhoon Rescue Pumper	S#1876	Fire Trucks	750,000	RC	Y	\$500	Y	\$500
111	2020	Chevrolet	Traverse Police Car	S#1889	Police	30,973	ACV	Y	\$500	Y	\$500
112	2020	Freightliner	M2 Salt Truck (Rd)	S#7348	Dump Trucks	76,570	ACV	Y	\$500	Y	\$500
113	2019	Ford	Fusion Police Car	S#6154	Police	23,835	ACV	Y	\$500	Y	\$500
114	2019	Ford	Fusion Police Car	S#6034	Police	23,835	ACV	Y	\$500	Y	\$500
115	2020	Chevrolet	Tahoe Fire Chief 73 Car w/Attached Equipment	S#4631	Passenger Car/Vans/Pickups	50,650	ACV	Y	\$500	Y	\$500



Schedule of Covered Vehicles

**West Chester Township,
Butler County**

Effective Date: 12/01/2023

Printed on: 11/09/2023

116	1968	Chevrolet	Chevelle-Confiscated Vehicle (PD)	S#2055	Passenger Car/Vans/Pickups	2,000	ACV	Y	\$500	Y	\$500
117	2020	Ford	Explorer Police Car	S#5658	Police	33,000	ACV	Y	\$500	Y	\$500
118	2020	Ford	Explorer Police Car	S#5659	Police	45,190	ACV	Y	\$500	Y	\$500
119	2020	Ford	Explorer Police Car	S#5661	Police	45,190	ACV	Y	\$500	Y	\$500
120	2020	Ford	Explorer Police Car	S#5660	Police	45,190	ACV	Y	\$500	Y	\$500
121	2021	Freightliner	M2 Crosswing Street Sweeper (Rd)	S#9669	Road Maintenance	269,958	ACV	Y	\$500	Y	\$500
122	2021	Freightliner	M2-106 Dump Truck w/ Salting Equipment (Rd)	S#0853	Dump Trucks	150,266	ACV	Y	\$500	Y	\$500
123	2021	Freightliner	M2-106 Dump Truck w/ Salting Equipment (Rd)	S#0854	Dump Trucks	150,266	ACV	Y	\$500	Y	\$500
124	2020	Ford	F550 QU13519 Bucket Truck (Rd)	S#0914	Lt. Med Trucks	105,000	ACV	Y	\$500	Y	\$500
125	2020	Ford	Explorer Police Car	S#9706	Police	42,843	ACV	Y	\$500	Y	\$500
126	2020	Ford	Explorer Police Car	S#9707	Police	42,843	ACV	Y	\$500	Y	\$500
127	2020	E-One	Typhoon Resue Pumper	S#3265	Fire Trucks	850,000	RC	Y	\$500	Y	\$500



Schedule of Covered Vehicles

**West Chester Township,
Butler County**

Effective Date: 12/01/2023

Printed on: 11/09/2023

128	2021	Ford	Explorer SUV (SV)	S#8718	Passenger Car/Vans/Pickups	28,983	ACV	Y	\$500	Y	\$500
129	2020	GMC	Sierra Pickup (Rd)	S#2152	Passenger Car/Vans/Pickups	30,097	ACV	Y	\$500	Y	\$500
130	2021	GMC	Sierra Pickup (Com Dev)	S#1478	Passenger Car/Vans/Pickups	30,056	ACV	Y	\$500	Y	\$500
131	2020	Ford	F150 Pickup Truck	S#1164	Police	33,135	ACV	Y	\$500	Y	\$500
132	2020	Ford	F150 Pickup Truck	S#1163	Police	33,135	ACV	Y	\$500	Y	\$500
133	2021	Ford	Explorer Police Car	S#7353	Police	45,000	ACV	Y	\$500	Y	\$500
134	2021	Ford	Explorer Police Car	S#7352	Police	45,000	ACV	Y	\$500	Y	\$500
135	2021	Ford	Explorer Police Car	S#7350	Police	45,000	ACV	Y	\$500	Y	\$500
136	2021	Ford	Explorer Police Car	S#7355	Police	45,000	ACV	Y	\$500	Y	\$500
137	2021	Ford	Explorer Police Car	S#7351	Police	45,000	ACV	Y	\$500	Y	\$500
138	2021	Ford	Explorer Police Car	S#5230	Police	32,182	ACV	Y	\$500	Y	\$500
139	2021	Ford	Explorer Police Car	S#5229	Police	32,182	ACV	Y	\$500	Y	\$500
140	2021	Ford	Explorer Police Car	S#6309	Police	50,000	ACV	Y	\$500	Y	\$500



Schedule of Covered Vehicles

**West Chester Township,
Butler County**

Effective Date: 12/01/2023

Printed on: 11/09/2023

141	2022	Freightliner	M2 Dump Truck (Service)	S#5297	Dump Trucks	78,689	ACV	Y	\$500	Y	\$500
142	2022	Freightliner	M2 Dump Truck (Service)	S#5298	Dump Trucks	78,689	ACV	Y	\$500	Y	\$500
143	2009	Ford	F350 Dump Truck 4x4 Super Duty (Rd)	S#5574	Dump Trucks	35,069	ACV	Y	\$500	Y	\$500
144	2007	Ford	Explorer (Admin)	S#2873	Passenger Car/Vans/Pickups	23,500	ACV	Y	\$500	Y	\$500
145	2021	Ford	Explorer (Admin)	S#6590	Passenger Car/Vans/Pickups	30,063	ACV	Y	\$500	Y	\$500
146	2018	Toyota	Sienna (PD)	S#1772	Police	36,535	ACV	Y	\$500	Y	\$500
147	2019	Toyota	4Runner Police Car	S#2960	Police	42,035	ACV	Y	\$500	Y	\$500
148	2021	Ford	Super Duty F350XL Reg Cab (Rd)	S#0845	Passenger Car/Vans/Pickups	46,427	ACV	Y	\$500	Y	\$500
149	2021	Chevrolet	Tahoe Fire Chief 72 Car w/Attached Equipment	S#7358	Passenger Car/Vans/Pickups	50,000	ACV	Y	\$500	Y	\$500
150	2022	Chevrolet	Silverado 3500 (Rd)	S#1270	Passenger Car/Vans/Pickups	49,958	ACV	Y	\$500	Y	\$500
151	2002	Ford	Wheel Chair Accessible Van (Admin)	S#6599	Lt. Med Trucks	50,000	ACV	Y	\$500	Y	\$500



Schedule of Covered Vehicles

**West Chester Township,
Butler County**

Effective Date: 12/01/2023

Printed on: 11/09/2023

152	2016	Ford	Transit Connect (Senior Van)	S#1837	Passenger Car/Vans/Pickups	30,000	ACV	Y	\$500	Y	\$500
153	2022	GMC	Sierra Limited Pickup (Road)	S#9654	Passenger Car/Vans/Pickups	34,311	ACV	Y	\$500	Y	\$500
154	2022	GMC	Sierra Limited Pickup (Road)	S#0857	Passenger Car/Vans/Pickups	34,311	ACV	Y	\$500	Y	\$500
155	2022	Ford	Explorer Police Interceptor Utility	S#5947	Police	45,000	ACV	Y	\$500	Y	\$500
156	2022	Ford	Explorer Police Interceptor Utility	S#5955	Police	45,000	ACV	Y	\$500	Y	\$500
157	2022	Ford	Explorer Police Interceptor Utility	S#5890	Police	45,000	ACV	Y	\$500	Y	\$500
158	2022	Ford	F550 Horton Ambulance Medic 74	S#9128	Ambulances	430,000	RC	Y	\$500	Y	\$500
159	2022	Ford	Escape (Admin)	S#1265	Passenger Car/Vans/Pickups	24,457	ACV	Y	\$500	Y	\$500
160	2022	Ford	Escape (PIE)	S#2887	Passenger Car/Vans/Pickups	23,907	ACV	Y	\$500	Y	\$500
161	2022	Ford	Explorer Police Interceptor Utility	S#8695	Police	45,000	ACV	Y	\$500	Y	\$500
162	2022	Toyota	Highlander (PD)	S#7629	Police	45,102	ACV	Y	\$500	Y	\$500
163	2022	Ford	Explorer Police Car	S#8445	Police	42,632	ACV	Y	\$500	Y	\$500



Schedule of Covered Vehicles

**West Chester Township,
Butler County**

Effective Date: 12/01/2023

Printed on: 11/09/2023

164	2023	Freightliner	M2 Dump Truck w/ Plow & Spreader	S#7246	Dump Trucks	179,129	ACV	Y	\$500	Y	\$500
165	2022	Ford	F550 Medic	S#5321	Ambulances	300,574	RC	Y	\$500	Y	\$500
166	2023	Chevrolet	Silverado 1500 Pick Up (Fire)	S#9269	Passenger Car/Vans/Pickups	70,000	ACV	Y	\$500	Y	\$500
167	2024	Freightliner	M2 Dump Truck w/ Plow (Rd)	S#3667	Dump Trucks	264,922	ACV	Y	\$500	Y	\$500
168	2024	Freightliner	Vactor	S#5630	Heavy	538,763	ACV	Y	\$500	Y	\$500
169	2020	Honda	Odyssey Police	S#4076	Police	34,285	ACV	Y	\$500	Y	\$500
170	2022	Toyota	Tacoma 4x4 Pickup	S#0885	Passenger Car/Vans/Pickups	51,000	ACV	Y	\$500	Y	\$500
171	2023	Ford	F350 Brush Truck (FD)	S#1534	Fire Trucks	86,738	RC	Y	\$500	Y	\$500

Total Location Vehicle Value: 20,213,134

Total ACV Value: 7,565,822 **Total RC Value:** 12,647,312 **Total SA Value:** 0 **Grand Total Vehicle Value:** 20,213,134

AGENDA ITEM COVER SHEET



Trustee Meeting Date:	Agenda Item Type:
November 14, 2023	Requisition Item
Submitted By:	
Rick L. Prinz, Fire Chief	

Motion:
Path Master, Inc. - \$17,687.00 - Purchase equipment for pre-emption lighting control devices (CIP 1668)

Background:
<p>This Capital Improvement Project was approved to purchase and install pre-emption equipment at Tylersville and Cincinnati-Dayton Roads and Tylersville and Kennesaw Drive.</p> <p>A United States Fire Administration research publication titled "Emergency Vehicle Safety Initiative" recognized that injuries and fatalities to both citizens and firefighters were significantly higher if an emergency vehicle struck a civilian vehicle, and the times in which this probability increased were as the vehicles entered intersections. The severity of the injuries and probability of death also increased at intersections due to the perpendicular collision. One of the prevalent strategies shown in this report, as well as other data and research, is the installation of pre-emption devices which control the intersection prior to emergency vehicle entry.</p> <p>In addition to increased safety, the pre-emption system decreases travel times to emergencies. A study conducted by Mid-Atlantic Universities Transportation Center in 2010 showed that the GPS based system we are asking to install reduced travel time by up to 31%.</p> <p>These two intersections are an addition to the current inventory of intersections covered and have been identified as a thoroughfare to our response travel routes on the north side of the township, as these are potential travel routes for stations 75, 71, and 74 for incidents in the north central portion of our township, which is located the furthest from existing fire stations. These two intersections allow Station 75 and station 71 to access the north central area quicker.</p> <p>The Pre-emption hardware is sold by an area exclusive dealer, Pathmaster from Twinsburg Ohio, at a cost of \$17,687.00, thus competitive quotes are not included. Pathmaster utilizes Capital Electric Line Builders to complete the installs of the equipment at a cost of \$17,085.00. This cost includes a traffic controller replacement, as the intersection is potentially too old to accept the pre-emption technology. If the intersection will accept the technology, \$6,327.00 will be deducted from the installation costs.</p> <p>Thank you for your consideration.</p>

Finance	Budgeted Item:	Yes; Operational, CIP		
	CIP #:	1668		
	TIF Info:			
	Purchase Order:	23001973	Total Encumbrance:	\$ 17,687.00



Path Master Inc.
 1960 Midway Drive
 Twinsburg OH 44087
 United States

Quote

Quote # C26432

10/12/2023

West Chester, City of

Randall W Hanifen, Ph.D.
 West Chester, City of
 Services Department
 9113 Cincinnati Dayton Rd.
 West Chester OH 45069
 United States

**GTT GPS Preemption For
 Tylersville Rd. & Cincinnati - Dayton Rd.
 Tylersville Rd. & Kennesaw Dr.**

Email: rhanifen@westchesteroh.org

Phone: (513) 759-7237

Fax:

Bid Date	Completion Date	Quote Expires	Terms	F.O.B.	Delivery
		30 Days	Net 30 Days	Twinsburg, Freight Allowed	30 - 60 Days, ARO

Bid Ref	Qty	Unit	Description	CL	Unit Sell	Ext. Sell
10.	2	EA	GTT/Opticom 764 Phase Selector	20G	\$3,899.00	\$7,798.00
20.	4	EA	Load Switch (If Required)	15	\$41.00	\$164.00
30.	2	EA	GTT/Opticom GPS/Radio Receiver With Side Of Strain Pole Mounting Bracket	20G	\$3,643.00	\$7,286.00
40.	200	FT	Cable for GTT/Opticom Model 3100 GPS Receiver	41	\$2.97	\$594.00
50.	4	EA	Dual LED Flood Light Confirmation Light Assembly With Span Wire Mounting Hardware	20	\$107.00	\$428.00
60.	600	FT	Signal Cable, IMSA 19-1-7B, # 14 AWG, 3 Conductor Stranded	41	\$0.605	\$363.00
70.	2	EA	2-Slot Preemption Rack Wired with Panel and 2 Load Switch Sockets	15	\$527.00	\$1,054.00

Load switches sold separately

Note: Quote is for materials only, does not include installation.

Total	\$17,687.00
--------------	--------------------

NOTES:

2023197B

1) In The Event That The Customer Modifies, Or Attempts To Modify, This Proposal In Any Manner, Including For Quantity Or Types Of Equipment, Path Master, Inc., Reserves The Right To Amend Its Pricing At Its Discretion

2) In The Event That The Customer Delays Shipment Of The Equipment Or Delays Taking Delivery Of The Equipment From Path Master, Inc., Path Master, Inc. Reserves The Right To Charge A Storage Fee of 3%.



Path Master Inc.
1960 Midway Drive
Twinsburg OH 44087
United States

Quote

Quote # C26432

10/12/2023

3) In The Event That The Customer Purchases Equipment From Another Supplier To Be Integrated With Path Master, Inc. Equipment, Path Master Inc. Reserves The Right To Charge Field Service Fees, If Requested To Perform The Integration Of Such Products, At Our Standard Field Service Rate of \$150 Per Hour With A Minimum Charge Of 3 Hours.

4) Freight Allowed Is Provided As On Shipment Of Entire Order. If Customer Requires Multiple Shipments, Path Master, Inc. Reserves The Right To Charge Extra Freight Fee As Applicable.

ORDERS ARE SUBJECT TO CREDIT APPROVAL

X _____

Authorized Signature

AGENDA ITEM COVER SHEET



Trustee Meeting Date:	Agenda Item Type:
November 14, 2023	Requisition Item
Submitted By:	
Rick L. Prinz, Fire Chief	

Motion:
Capitol Electric Line Builders - \$17,085.00 - Install pre-emption lighting control devices (CIP 1668)

Background:
<p>This Capital Improvement Project was approved to purchase and install pre-emption equipment at Tylersville and Cincinnati-Dayton Roads and Tylersville and Kennesaw Drive.</p> <p>A United States Fire Administration research publication titled "Emergency Vehicle Safety Initiative" recognized that injuries and fatalities to both citizens and firefighters were significantly higher if an emergency vehicle struck a civilian vehicle, and the times in which this probability increased were as the vehicles entered intersections. The severity of the injuries and probability of death also increased at intersections due to the perpendicular collision. One of the prevalent strategies shown in this report, as well as other data and research, is the installation of pre-emption devices which control the intersection prior to emergency vehicle entry.</p> <p>In addition to increased safety, the pre-emption system decreases travel times to emergencies. A study conducted by Mid-Atlantic Universities Transportation Center in 2010 showed that the GPS based system we are asking to install reduced travel time by up to 31%.</p> <p>These two intersections are an addition to the current inventory of intersections covered and have been identified as a thoroughfare to our response travel routes on the north side of the township, as these are potential travel routes for stations 75, 71, and 74 for incidents in the north central portion of our township, which is located the furthest from existing fire stations. These two intersections allow Station 75 and station 71 to access the north central area quicker.</p> <p>The pre-emption hardware is sold by an area exclusive dealer, Pathmaster from Twinsburg, Ohio, at a cost of \$17,687.00, utilizing Capital Electric Line Builders to complete the installs, thus competitive quotes are not included. This cost includes a traffic controller replacement, as the intersection is potentially too old to accept the pre-emption technology. If the intersection will accept the technology, \$6,327.00 will be deducted from the installation costs.</p> <p>Thank you for your consideration.</p>

Finance	Budgeted Item:	Yes; Operational, CIP		
	CIP #:	1668		
	TIF Info:			
	Purchase Order:	23001972	Total Encumbrance:	\$ 17,085.00

PROJ: 2024 GTT GPS Preemption Installation
LOC: West Chester, OH
EST: Steve Taulbee
P.O. Box 1353, Dayton, OH 45401
Tel: 937-424-2550 Fax: 937-297-1365

REF #	ITEM DESCRIPTION	QUANTITY	UNIT	BID PRICE	
				UNIT	TOTAL
1	Tylersville Rd & Cin-Day Rd	-	-	-	-
2	INSTALL CUSTOMER SUPPLIED GTT GPS PREEMPTION WITH CONFIRMATION LIGHTS	1.00	LS	5,739.00	5,739.00
3	REPLACE EXISTING TRAFFIC SIGNAL CONTROLLER (IF REQUIRED)	1.00	LS	6,327.00	6,327.00
4	Tylersville Rd & Kennesaw Rd	-	-	-	-
5	INSTALL CUSTOMER SUPPLIED GTT GPS PREEMPTION WITH CONFIRMATION LIGHTS	1.00	LS	5,019.00	5,019.00
GRAND TOTAL					\$17,085.00

23001972



3150 Encrete Lane • Dayton., OH 45439 |

Voice (937) 424-2550 • Fax (937) 297-1365

QUOTE SHEET

To: Randall Hanifen Fax # _____
 Company: West Chester, OH Phone # _____
 # Of Pages: 2 Date: 10/11/2023
 From: Steve Taulbee
 RE: 2024 GTT GPS Preemption Installation

Please find attached our quotation for this project.

The following clarifications apply to this quotation:

- This quote is for the installation of GTT GPS Preemption equipment, to be purchased and supplied by West Chester, at the intersections of Tylersville Rd & Cin-Day Rd and at Tylersville Rd & Kennesaw Rd.
- Capital Invoices are to be paid in full upon completion of work within 30 days of date on invoice, with no retention withheld. Sales tax is *not* included. Performance bond (if required) is not included.
- Work shall be performed during our normal work hours; premium time is excluded.
- Maintenance of Traffic and Mobilization are included in the quote. Cost of LEO, if required, is not included.
- Quote includes the installation of GTT GPS Preemption equipment, with LED confirmation lights, at the intersections of Tylersville Rd and Cin-Day Rd and at Tylersville Rd & Kennesaw Rd. West Chester is purchasing all preempt equipment and supplying to Capital Electric Line Builders for installation.
- Quote assumes existing conduit from controller foundation to pole foundation, is in good condition and of adequate size to accommodate additional wiring for preemption. After visual inspection it appears conduit size will allow for additional wiring to be installed.
- We are waiting on confirmation from Baldwin & Sours, as to whether the existing traffic signal controller will operate the preemption equipment and confirmation lights at the intersection of Tylersville Rd & Cin-Day Rd. It is possible that the existing controller will need to be replaced. If it does not need replaced the bid item would be non-performed.

- **Please note: Capital Electric reserves the right to revise pricing if all quoted items are not awarded.**

Thank you for the opportunity,

Steve Taulbee (937) 604-6115

CONFIDENTIALITY NOTICE: The documents accompanying this transmission contain certain confidential information belonging to the sender, which is legally privileged. The information is intended only for the use of the individual or entitled named above. If you are not the intended recipient, you are hereby notified that any disclosure, copying, distribution or the taking of any action in reliance on the contents of this telecopy information is strictly prohibited. If you have received this telecopy in error, please notify us immediately by telephone to arrange for the return of the document(s) to us. Thank you.

AGENDA ITEM COVER SHEET

Trustee Meeting Date:	Agenda Item Type:
November 14, 2023	Requisition Item
Submitted By:	
Rick L. Prinz, Fire Chief	

Motion:
Darrin Snyder - \$9,350.00 - Paint exterior metal surfaces of Station 72 and Station 75 (CIP 1683)

Background:
<p>Fire Station 72 and Station 75 are in excess of 20 years old in age. Due to degradation of the painted metal surfaces, CIP 1683 was created at a cost cap of \$30,000 to repaint.</p> <p>Three quotes were obtained to paint metal surfaces to include doors, window frames, and railings. Darrin Snyder provided the most cost-effective quote at \$4,550.00 for Station 75 and \$4,800.00 for Station 72.</p> <p>Competitive quotes from EMCOR and Masters Touch are included for reference.</p>

Finance	Budgeted Item:	Yes; Operational, CIP		
	CIP #:	1683		
	TIF Info:			
	Purchase Order:	23001957	Total Encumbrance:	\$ 9,350.00



SHERWIN-WILLIAMS.

**PROPOSAL for West Chester Fire Department
9119 Cincinnati-Dayton Road
West Chester, Ohio 45069
Randall W. Hanifen, Ph.D., Assistant Fire Chief**

WORK @ West Chester Fire Department, 7588 Towers Place Blvd:

- Pressure wash all areas to be painted with Paint PreWash
- Spray 18 Window Frames exterior only - Green color match
- Spray 4-Doors Outside Only - Green Color Match
- Spray 10 Downspour Bases - Color Match
- Spray 2 Large Metal Wall Sign in Front & Back - Color Match
- Touchup Roof in front where previous repairs were made.

LABOR.....\$4200.00

Materials (estimated at my cost).....\$ 250.00
(2-Gal SW Emerald Ext Satin, primer, prep, painters tape, plastic etc.)

TOTAL.....\$4550.00

We are fully insured with Utica First Policy #ART3000895890. We use only "Best In Class" products. All prep wash is safe to the environment and paint has low VOC. We keep a very neat work environment.

SNYDER Property Services * 1298 Shawnee Run * Maineville, OH * 614-264-7632

Confirming details included 9/28/23 RWH



SHERWIN-WILLIAMS.

**PROPOSAL for West Chester Fire Department
9119 Cincinnati-Dayton Road
West Chester, Ohio 45069
Randall W. Hanifen, Ph.D., Assistant Fire Chief**

WORK @ West Chester Fire Department, 7715 John Cox Road:

- Pressure wash all areas to be painted with Paint PreWash
- Spray 43 Window Frames exterior only - color match
- Spray 4-Doors Outside Only - Color Match
- Spray 11 Domed Walk Lights & 3 Ground Spot Lights - Color Match
- Spray 32' of steel railing, some areas will need scraped

LABOR.....\$4500.00

Materials (estimated at my cost).....\$ 300.00
(3-Gal SW Emerald Ext Satin, primer, prep, painters tape, plastic)

TOTAL.....\$4800.00

We are fully insured with Utica First Policy #ART3000895890. We use only "Best In Class" products. All prep wash is safe to the environment and paint has low VOC. We keep a very neat work environment.

SNYDER Property Services * 1298 Shawnee Run * Maineville, OH * 614-264-7632

Confirmed labels included 9/28/23 RLW



EMCOR Facilities Services, Inc.
9655 Reading Road
Cincinnati, OH 45215
Phone: 513.948.8469

September 20, 2023

Quote # 2365RM

West Chester Township
Firehouse #75
7588 Tylers Pl Blvd
West Chester, Ohio 45069

Attn: John Puthoff
Subject: Exterior Prep & Painting

Mr. John Puthoff

EMCOR Facilities Services, Inc. is pleased to offer the following proposal for the above-mentioned project

Scope of Work #1:

Furnish labor, material, and equipment to perform the following:

Exterior window frames, doors, lights, signage, and railings

- Clean exterior facing surface of window frames with Duraprep /Prep 88 to bring back, original color (cleaner may not clean all oxidization off windows to bring back to original color and sheen)
- Prep and apply two coats of PPG breakthrough to all exterior window lintels.
- Prep and apply two coats of PPG breakthrough to four exterior 36" metal doors.
- Prep and apply two coats of PPG Breakthrough to signage on front and rear of building reading "West Chester Fire Department"
- Prep and apply two coats of PPG Breakthrough to 2-3'x3' and 1-4'x6' exterior vent
- Prep and apply two coats of PPG Breakthrough to twelve 4"x4"x1.5" downspout metal extensions
- Prep and apply two coats of PPG Breakthrough to 6'x8' lower section of metal roof at front of building and 6'x8' section of metal roof at rear of building
- Custom green metal roof match will be a close match but cannot guarantee a exact match
- Custom green match to be used on all painted surfaces- all paint matches will be a close match but cannot guarantee an exact match

Note: As oxidation on surfaces varies for the amount of hardness on the surface, Prep 88 may not restore window frames to the original color or sheen. This prep will need to be performed whether or not the window frames are painted.

Total: Eleven thousand seven hundred and eighty-four dollars \$11,784.00



Quote# 2355RM

Scope of work #2:

Furnish labor, material, and equipment to perform the following:

Exterior window frame painting

- Apply two coats of PPG breakthrough to exterior facing surface of window frames.

Add to Price on previous page: \$6,298.00

Total for Scope #1 and #2:
Eighteen thousand and eighty-two dollars \$18,082.00

Qualifications:

1. All work to be performed during normal business hours.
2. EMCOR Facilities Services, Inc. is not responsible for hidden conditions.
3. No other work is implied or covered.
4. Tax is included in price.
5. Building permits and stamped drawings are not included.
6. Permitting notification and removal and/or abatement of any hazardous material are not included and shall be the responsibility of the owner. The condition could cause a stoppage of work until removal is complete and area is verified to be free of all hazardous contaminants.

Due to anticipated changes in material cost, EMCOR Facilities Services, Inc. will only allow a 15-day timeframe for proposal acceptance.

Thank you for the opportunity to quote this project.

Approved by: _____ Date: _____ PO #: _____
(PRINT NAME)

Signature: _____

Sincerely,

Robert Mathieu
Project Superintendent, Painting
EMCOR Facilities Services, Inc.
O: 513.679.3278 | C: 513.835.1486





EMCOR Facilities Services, Inc.
9655 Reading Road
Cincinnati, OH 45215
Phone: 513.948.8469

September 20, 2023

Quote # 2354RM

West Chester Township
Firehouse #72
7715 John rd.
West Chester, Ohio 45069

Attn: John Puthoff

Subject: Exterior Prep & Painting

Mr. John Puthoff

EMCOR Facilities Services, Inc. is pleased to offer the following proposal for the above-mentioned project

Scope of Work #1:

Furnish labor, material, and equipment to perform the following:

Exterior window frames, doors, lights, signage, and railings

- Clean exterior facing surface of window frames with Duraprep /Prep 88 to bring back, original color (cleaner may not clean all oxidization off windows to bring back to original color and sheen)
- Prep and apply two coats of PPG breakthrough to all exterior window lintels.
- Prep and apply two coats of PPG breakthrough to three exterior 36" metal doors.
- Prep and apply two coats of PPG breakthrough to six each, light bollards.
- Prep and apply two coats of PPG breakthrough to four each (1'x4") exterior light fixtures.
- Prep and apply two coats of PPG breakthrough to approximately 42' of exterior railings.
- Prep and apply two coats of PPG Breakthrough to signage on front of building reading "West Chester Fire Department"
- Bronze tone color to be used on all painted surfaces

Note: As oxidation on surfaces varies for the amount of hardness on the surface, Prep 88 may not restore window frames to the original color or sheen. This prep will need to be performed whether or not the window frames are painted.

Total: Ten thousand seven hundred and forty-seven dollars \$10,747.00



Quote# 2354RM

Scope of work #2:

Furnish labor, material, and equipment to perform the following:

Exterior window frame painting

- Apply two coats of PPG breakthrough to exterior facing surface of window frames.

Add to Price on previous page: \$6,868.00

Total for Scope #1 and #2:

Seventeen thousand six hundred and fifteen dollars \$17,615.00

Qualifications:

1. All work to be performed during normal business hours.
2. EMCOR Facilities Services, Inc. is not responsible for hidden conditions.
3. No other work is implied or covered.
4. Tax is included in price.
5. Building permits and stamped drawings are not included.
6. Permitting notification and removal and/or abatement of any hazardous material are not included and shall be the responsibility of the owner. The condition could cause a stoppage of work until removal is complete and area is verified to be free of all hazardous contaminants.

Due to anticipated changes in material cost, EMCOR Facilities Services, Inc. will only allow a 15-day timeframe for proposal acceptance.

Thank you for the opportunity to quote this project.

Approved by: _____ Date: _____ PO #: _____
(PRINT NAME)

Signature: _____

Sincerely,

Robert Mathieu
Project Superintendent, Painting
EMCOR Facilities Services, Inc.
O: 513.679.3278 | C: 513.835.1486





PROPOSAL

Proposal ID: Q4515

Page 1 of 2

Job Type: Exterior Painting

Estimator: Frehier Vargas

Date: 9/25/2023

5874 Eldon Drive
Liberty Township, OH 45011

Office: (513) 759-1685

Cell: (513) 200-1029

Email: fvargas@mastertouchpainting.com

Proposal Submitted To:

Name: Randall Hanifen

Business:

Address: 7588 Tylers Pl

Blvd

West Chester, OHIO 45069

Phone: (513) 759-7237

Email:

rhanifen@westchesteroh.org

We hereby submit specifications and estimates for:		* \$2,000,000 Liability Insurance Coverage * Full workers compensation coverage
Area	Job Description	Customer Approval
WINDOWS (37)	PAINT/ COLOR MATCH/ 2 COATS	
SINGLE DOOR & FRAME WITH TOP WINDOWS (2)	PAINT/ COLOR MATCH/ 2 COATS	
BOTTOM DRAIN (9)	PAINT/ COLOR MATCH/ 2 COATS	
ENTRANCE DOOR	PAINT / COLOR MATCH/ 2 COATS	
SIDE DOOR	PAINT / COLOR MATCH/ 2 COATS	
BACK DOOR	PAINT / COLOR MATCH/ 2 COATS	
ELECTRIC BOX BIG & COUNTER TOPS	PAINT / COLOR MATCH/ 2 COATS	
NOTES	*NOTES: ALL PREP REQUIRED / DTM PAINT	

Total \$ 6,950.00

Notes:

OPTIONAL ITEMS

>ROOF---SPOT PAINT WITH DTM WILL BE CHARGE TIME + MATERIAL AT A CHARGE \$55/HR _____

>PAINT SIGN OF WEST CHESTER FIRE DEPARTMENT-----\$1150ea X 2 SIDES _____

>CARPENTRY REPAIRS WOULD BE CHARGED TIME PLUS MATERIAL AT A RATE OF \$55 AN HOUR _____

* We usually allow 2-3 hours per area. If upon close inspection we see that there may be more than 3 hours of labor involved, the customer is informed and the repair is not started without customer's approval.

ESTIMATE INCLUDES

- * INCLUDES ALL LABOR AND MATERIALS
- *INCLUDES AREAS PREVIOUSLY PAINTED ON ITEMS DESCRIBED ABOVE
- * INCLUDES SHERWIN WILLIAMS SOLID STAIN, FLAT OR SATIN ACRYLIC PAINT
- * INCLUDES CARPENTRY INSPECTION
- * INCLUDES STANDARD PREPARATION AS REQUIRED (.Pressure washing, scraping, carpentry inspection, caulking , sanding & priming of all bare wood)



PROPOSAL

Proposal ID: Q4515

Page 2 of 2

Job Type: Exterior Painting

Estimator: Frehier Vargas

Date: 9/25/2023

5874 Eldon Drive
Liberty Township, OH 45011

Office: (513) 759-1685

Cell: (513) 200-1029

Email: fvargas@mastertouchpainting.com

Proposal Submitted To:

Name: Randall Hanifen

Business:

Address: 7588 Tylers Pl
Blvd

West Chester, OHIO 45069

Phone: (513) 759-7237

Email:

rhanifen@westchesteroh.org

EXCLUSIONS AND QUALIFICATIONS

- > No verbal estimates - All changes must be in writing & approved by customer prior to commencing work
- > All discounts have been applied
- > Includes mildew resistant additive on trim
- > Daily updates to customer as to job progress / customer to receive any leftover paint
- > Excludes everything else not mentioned in the general description above

Estimate excludes everything else not mentioned in the general description above

We hereby propose to furnish material and labor, complete in accordance with the above specifications for the sum of: \$ 6,950.00

with payment to be made as follows:	35% equal to	\$2,432.50 due upon signing
	65% equal to	\$4,517.50 due upon job completion and final inspection

*Coupon valid at time of estimate only

All material is guaranteed to be as specified. All work is to be completed in a workmanlike manner according to standard practices. Any alteration or deviation from specifications involving extra costs will be executed upon written orders and will become an extra charge over and above the estimate. All agreements contingent upon strikes, accidents or delays beyond our control. Owner to carry fire, tornado and other necessary insurance. Our workers are fully covered by workers compensation insurance All unpaid balances due under this contract/proposal shall bear interest at the rate of 12% per year. If customer fails to pay any amount due and owing under this contract/proposal, Master Touch Ptg. & Restoration, INC shall be entitled to recover its reasonable Attorney Fees and cost during the course of any lawsuit, arbitration or other dispute resolution proceeding. If customer cancels after three days of signing contract a \$250 cancellation fee will apply. If work has started (Color consultation, pressure washing or painting) the full deposit will be forfeited

Authorized
Signature Frehier Vargas

Note :This proposal may be withdrawn by us if not accepted within 30 days.

Acceptance of proposal - The above prices, specifications and conditions are satisfactory and are hereby accepted. You are authorized to do the work as specified. Payment will be made as outlined above

Date of Acceptance:

Signature:



RATED A+



PROPOSAL

Proposal ID: Q4514

Page 1 of 2

Job Type: Exterior Painting

Estimator: Frehier Vargas

Date: 9/25/2023

5874 Eldon Drive
Liberty Township, OH 45011

Office: (513) 759-1685

Cell: (513) 200-1029

Email: fvargas@mastertouchpainting.com

Proposal Submitted To:

Name: Randall Hanifen

Business: Firefighter

Address: 7715 John Rd
West Chester, OHIO 45069

Phone: (513) 759-7237

Email:

rhanifen@westchesteroh.org

We hereby submit specifications and estimates for:		* \$2,000,000 Liability Insurance Coverage * Full workers compensation coverage
Area	Job Description	Customer Approval
FRONT ENTRANCE	PAINT / COLOR MATCH / 2 COATS	
WINDOWS (20) FRONT	PAINT / COLOR MATCH / 2 COATS	
RAILING/PATIO	PAINT / COLOR MATCH / 2 COATS/ PREP REQUIRED SAND DTM	
LENTIL	PAINT / COLOR MATCH / 2 COATS	
BACK DOOR	PAINT / COLOR MATCH / 2 COATS	
SIDE DOOR & FRAME	PAINT / COLOR MATCH / 2 COATS	
RAILING/SIDE DOOR	PAINT / COLOR MATCH / 2 COATS	
NOTES	*NOTES: ALL PREP REQUIRED / DTM PAINT	

Total \$ 5,800.00

Notes:

OPTIONAL ITEMS

>PAINT SIGN OF WEST CHESTER FIRE DEPARTMENT-----\$1150ea X 1 SIDE_____

>CARPENTRY REPAIRS WOULD BE CHARGED TIME PLUS MATERIAL AT A RATE OF \$55 AN HOUR_____

* We usually allow 2-3 hours per area. If upon close inspection we see that there may be more than 3 hours of labor involved, the customer is informed and the repair is not started without customer's approval.

>
>
>

ESTIMATE INCLUDES

- * INCLUDES ALL LABOR AND MATERIALS
- *INCLUDES AREAS PREVIOUSLY PAINTED ON ITEMS DESCRIBED ABOVE
- * INCLUDES SHERWIN WILLIAMS SOLID STAIN, FLAT OR SATIN ACRYLIC PAINT
- * INCLUDES CARPENTRY INSPECTION
- * INCLUDES STANDARD PREPARATION AS REQUIRED (.Pressure washing, scraping, carpentry inspection, caulking , sanding & priming of all bare wood)
- *INCLUDES ALL REQUIRED CARE (Blue taping, drop cloths)
- *INCLUDES FIVE (5) YEAR LIMITED WARRANTY

PAYMENT OPTIONS



PROPOSAL

Proposal ID: Q4514

Page 2 of 2

Job Type: Exterior Painting

Estimator: Frhier Vargas

Date: 9/25/2023

5874 Eldon Drive
Liberty Township, OH 45011

Office: (513) 759-1685

Cell: (513) 200-1029

Email: fvargas@mastertouchpainting.com

Proposal Submitted To:

Name: Randall Hanifen

Business: Firefighter

Address: 7715 John Rd

West Chester, OHIO 45069

Phone: (513) 759-7237

Email:

rhanifen@westchesteroh.org

EXCLUSIONS AND QUALIFICATIONS

- > No verbal estimates - All changes must be in writing & approved by customer prior to commencing work
- > All discounts have been applied
- > Includes mildew resistant additive on trim
- > Daily updates to customer as to job progress / customer to receive any leftover paint
- > Excludes everything else not mentioned in the general description above

Estimate excludes everything else not mentioned in the general description above

We hereby propose to furnish material and labor, complete in accordance with the above specifications for the sum of: \$ 5,800.00

with payment to be made as follows:	35% equal to	\$2,030.00 due upon signing
	65% equal to	\$3,770.00 due upon job completion and final inspection

*Coupon valid at time of estimate only

All material is guaranteed to be as specified. All work is to be completed in a workmanlike manner according to standard practices. Any alteration or deviation from specifications involving extra costs will be executed upon written orders and will become an extra charge over and above the estimate. All agreements contingent upon strikes, accidents or delays beyond our control. Owner to carry fire, tornado and other necessary insurance. Our workers are fully covered by workers compensation insurance All unpaid balances due under this contract/proposal shall bear interest at the rate of 12% per year. If customer fails to pay any amount due and owing under this contract/proposal, Master Touch Ptg & Restoration, INC shall be entitled to recover its reasonable Attorney Fees and cost during the course of any lawsuit, arbitration or other dispute resolution proceeding. If customer cancels after three days of signing contract a \$250 cancellation fee will apply. If work has started (Color consultation, pressure washing or painting) the full deposit will be forfeited

Authorized
Signature Frhier Vargas

Note :This proposal may be withdrawn by us if not accepted within 30 days.

Acceptance of proposal - The above prices, specifications and conditions are satisfactory and are hereby accepted. You are authorized to do the work as specified. Payment will be made as outlined above

Date of Acceptance:

Signature:



RATED A+

AGENDA ITEM COVER SHEET



Trustee Meeting Date:	Agenda Item Type:
November 14, 2023	Requisition Item
Submitted By:	
Barb Wilson, Director of Public Information & Engagement	

Motion:
The Plant Detail - \$12,814.00 - Purchase holiday decorating service for 1823 Plaza, The Square and Township Administration Building/Fire Headquarters

Background:
<p>To demonstrate a festive, holiday appearance for the community, The Plant Detail has been contracted each year since 2008 to install outdoor holiday decor at Township facilities.</p> <p>The holiday lighting package from The Plant Detail includes the installation of energy efficient commercial-grade LED lights. They own, install, maintain and take down the lighting features each year.</p> <p>In 2008, West Chester began out-sourcing installation of holiday lights as it offered cost savings in material and labor. The Plant Detail’s price continues to be the most competitive in a limited market of like service providers as they have made the initial investment in lights and materials for our project and have only to accommodate for replacements as needed.</p> <p>Although West Chester will not host a Very Merry Takeover in 2023, the decor in these high-profile locations create sense of community and spirit.</p>

Finance	Budgeted Item:	Yes; Operational		
	CIP #:			
	TIF Info:			
	Purchase Order:	23001935	Total Encumbrance:	\$ 12,814.00



4554 Port Union Road
Hamilton, Ohio 45011

513.860.1090

www.theplantdetail.com

West Chester Township
Attn: Barb Wilson
9113 Cincinnati-Dayton Road
West Chester, Ohio 45069

October 16, 2023

West Chester Township Holiday 2023

QTY	DESCRIPTION	LOCATION	AMOUNT
1	Blue Spruce Tree LED lights & balls	Firehouse/Admin	\$ 1100.00
2	12' LED Custom tree of lights	Side fountains	\$ 2600.00
1	18' LED Custom tree of lights	Round about fountain	\$ 1800.00
5	Light posts wrapped with garland	Street Median	\$ 610.00
10	Exterior red bows & white LED's	" "	included
5	Light posts wrapped with garland	Surrounding clocktower	\$ 610.00
10	Exterior red bows & white LED's	" "	included
8	Medium trees trunk & canopy wrapped	" "	\$ 2320.00
4	Small trees trunk & canopy wrapped	1823 Plaza	\$ 580.00
12	Various sized lighted ornament balls	1823 Fountain	\$ 950.00
2	Light posts wrapped with garland	1823 Plaza Poles	\$ 244.00
4	Exterior red bows & white LED's	" "	included

Preparation, delivery, installation, maintenance during the Holiday Season,
removal and prep for storage. \$ 1170.00

GRAND TOTAL \$ 11974.00

Option to add (5) lighted LED 18" garlands, balls & (8) extra large bows to
the Admin Building sign & the Firehouse sign **ADD \$ 840.00**

AGENDA ITEM COVER SHEET

Trustee Meeting Date:	Agenda Item Type:
November 14, 2023	Requisition Item
Submitted By:	
Colonel Joel M. Herzog, Chief of Police	

Motion:
Emcor Facilities Services, Inc. - \$35,000.00 - Paint and install carpet at the Police Department (CIP 1918)

Background:
<p>In order to maintain public appearance, the Police Department is requesting Trustee approval to refresh the squad room, briefing /training room, soft interview rooms and surrounding hallway with paint, and carpet for the Road Lieutenant offices.</p> <p>The paint in these areas is original from when we moved into the building nearly 16 years ago and is showing significant wear and tear.</p> <p>The Police Department requests a Purchase Order in the amount of \$35,000.00 which includes a contingency of \$1,343.00. The purchase will use TIF Funds.</p>

Finance	Budgeted Item:	N/A; CIP, TIF		
	CIP #:	1918		
	TIF Info:	219		
	Purchase Order:	REQ 23001623	Total Encumbrance:	\$ 35,000.00



EMCOR Facilities Services, Inc.
9655 Reading Road
Cincinnati, OH 45215
Phone: 513.948.8469

September 29, 2023

West Chester Township Police Dept.
9577 Beckett Rd.
West Chester, Ohio 45069

Attention: John Puthoff

Reference: West Chester Township Police Department Carpet & Paint

EMCOR Facilities Services, Inc. is pleased to offer the following proposal for the above-mentioned project.

General Conditions:

- All work is to be completed during normal working hours
- Daily and final cleanup
- Project Management

Scope of work: Paint & Carpet Installation

- Provide labor and material to do minor patching, spot prime, apply one coat of binding primer and one coat of PPG Speedhide, Zero Eggshell to block walls approximately 9120 sq ft.
- Provide labor and material to apply two coats of PPG Breakthrough Semigloss to (30) door frames hall side ONLY, (1) door, and (6) window frames both sides, and (5) handrails in the Squad Room area.
- Provide labor and material to install new Cubic Color Construction carpet tile in three small offices adjacent to the Squad Room totaling 435 sq ft including the landings outside the offices. Provide labor and material to install rubber stair treads and risers on two sets of stairs leading to the offices in the area.

Total Price: \$ 33,657.00

Qualifications:

Electrical License
OH 20578

HVAC License
OH 48155

Plumbing License
OH 13548

www.emcorfacilities.com

- Unforeseen conditions are not included
- No other work is implied or covered
- Permitting, notification, removal and/or abatement of any hazardous material are not included and are the responsibility of the owner. This condition could cause a stoppage of work until corrected and area is certified free of all hazardous contaminants
- No permits, drawings or engineering have been figured

Due to the anticipated rise in material cost, this proposal is good for (15) calendar days from the date of this document

Please review the information for scope and cost comments. The cost may need to be revised depending on any new requirement changes

If you have any questions, please contact me at (513) 910-0655

Sincerely,

Joe Gross
EMCOR Facilities Services, Inc.

AGENDA ITEM COVER SHEET



Trustee Meeting Date:	Agenda Item Type:
November 14, 2023	Requisition Item
Submitted By:	
Arun Hindupur, Director of Public Works/Community Services	

Motion:
Morton Salt, Inc. - \$225,000.00 - Purchase road salt for 2023-2024 winter season

Background:																																								
<p>In preparation for the 2023-2024 winter season, the Butler County Engineer’s Office solicited bids and negotiated a contract for the purchase of road salt. Morton Salt, Inc. was selected for this season’s salt purchase. The contract price is \$90.31 per ton dumped.</p> <p>Below is a history of road salt pricing:</p> <table border="1"> <thead> <tr> <th>Year</th> <th>Amount</th> <th>Purchased (Tons)</th> <th>Price per Ton Dumped</th> </tr> </thead> <tbody> <tr> <td>2014 – 2015</td> <td></td> <td>7,500</td> <td>\$66.71</td> </tr> <tr> <td>2015 – 2016</td> <td></td> <td>2,300</td> <td>\$74.19</td> </tr> <tr> <td>2016 – 2017</td> <td></td> <td>1,098</td> <td>\$68.42</td> </tr> <tr> <td>2017 – 2018</td> <td></td> <td>3,348</td> <td>\$58.73</td> </tr> <tr> <td>2018 – 2019</td> <td></td> <td>3,143</td> <td>\$62.98</td> </tr> <tr> <td>2019 – 2020</td> <td></td> <td>1,118</td> <td>\$73.21</td> </tr> <tr> <td>2020 – 2021</td> <td></td> <td>4,020</td> <td>\$74.71</td> </tr> <tr> <td>2021 – 2022</td> <td></td> <td>3,508</td> <td>\$76.29</td> </tr> <tr> <td>2022 – 2023</td> <td></td> <td>2,527</td> <td>\$85.92</td> </tr> </tbody> </table> <p>The Community Services Department budgeted \$395,000.00 for road salt in 2023, and an additional \$250,000.00 for 2024. We refilled the dome in the spring and currently have over 4,000 tons of salt on hand.</p> <p>The Community Services Department requests a Purchase Order in the amount of \$225,000.00 for the purchase of road salt to begin the 2023-2024 winter season.</p>	Year	Amount	Purchased (Tons)	Price per Ton Dumped	2014 – 2015		7,500	\$66.71	2015 – 2016		2,300	\$74.19	2016 – 2017		1,098	\$68.42	2017 – 2018		3,348	\$58.73	2018 – 2019		3,143	\$62.98	2019 – 2020		1,118	\$73.21	2020 – 2021		4,020	\$74.71	2021 – 2022		3,508	\$76.29	2022 – 2023		2,527	\$85.92
Year	Amount	Purchased (Tons)	Price per Ton Dumped																																					
2014 – 2015		7,500	\$66.71																																					
2015 – 2016		2,300	\$74.19																																					
2016 – 2017		1,098	\$68.42																																					
2017 – 2018		3,348	\$58.73																																					
2018 – 2019		3,143	\$62.98																																					
2019 – 2020		1,118	\$73.21																																					
2020 – 2021		4,020	\$74.71																																					
2021 – 2022		3,508	\$76.29																																					
2022 – 2023		2,527	\$85.92																																					

Finance	Budgeted Item:	Yes; Operational		
	CIP #:			
	TIF Info:			
	Purchase Order:	23001945	Total Encumbrance:	\$ 225,000.00

CONTRACT NO 2023-1M

THIS CONTRACT, made and entered into this 10th day of July in the year Two Thousand Twenty Three by and between the Board of County Commissioners of Butler County, Ohio ("COUNTY"), and Morton Salt, Inc. ("CONTRACTOR").

WITNESSETH: That the CONTRACTOR has agreed, and by these presents does agree with the COUNTY for the consideration herein below mentioned, to provide at CONTRACTOR'S own proper cost and expense all necessary materials and labor of every description, and to carry out complete in good, firm, and substantial manner the Furnishing of ODOT Spec. 712.03 Bulk-Treated Sodium Chloride for Butler County, Cities, Villages and Townships. Exhibit A (Specifications), Exhibit B (Schedule for Billing and Delivery), the Legal Ad, the Description of Bid, the Schedule of Prices, the requirements of the Invitation to Bid (also including necessary forms), the Contract Bond, and any addenda or clarifications issued prior to bid selection are hereby incorporated into this contract.

The quantity of 8,850 tons (more or less, as provided in the Specifications) of ODOT Spec. 712.03 Bulk-Treated Sodium Chloride for County use shall be provided at a unit price of \$105.31 per ton for pile and \$90.31 per ton for dump. The quantity of 6,580 tons (more or less, as provided in the Specifications) of ODOT Spec. 712.03 Bulk-Treated Sodium Chloride for City and Village use shall be provided at a unit price of \$105.31 per ton for pile and \$90.31 per ton for dump. The quantity of 12,300 tons (more or less, as provided in the Specifications) of ODOT Spec. 712.03 Bulk-Treated Sodium Chloride for Township use shall be provided at a unit price of \$105.31 per ton for pile and \$90.31 per ton for dump. The quantities for County, City, Village and Township use are to be billed and shipped directly to the County, City, Village or Township, as indicated on the "Schedule for Billing and Delivery" and as arranged directly between each jurisdiction and the CONTRACTOR, at the foregoing unit prices without further cost to any jurisdiction for delivery

CONTRACTOR hereby agrees to release, indemnify, defend, and hold harmless Butler County and its agencies, offices, officials, and all employees thereof from and against any and all liability, actions, claims, suits, demands, costs, expenses, penalties, fines, or judgments on account of any loss or damage to any person or property or any failure to comply with governmental laws and regulations which result from or arise out of any act or omission of the Contractor or its subcontractors or the agents, officers, employees, or material men of either, jointly or severally, while engaged in the work to be performed under this contract.

CONTRACTOR shall be responsible for the Contractor's work under this contract, and for the work of other parties undertaking any portion of the Contractor's responsibility or obligation, including compliance with all applicable local, State, and Federal laws and regulations concerning workplace safety

IN WITNESS WHEREOF, the said COUNTY of Butler, Ohio, has caused its name to be affixed by the Board of County Commissioners, and CONTRACTOR has set its hand on the day and year aforesaid.

Anthony Patton

Anthony Patton (Jun 22, 2023 15:27 CDT)

Authorized Representative of Contractor

Anthony T Patton

Printed Name

Director, Bulk Deicing US Government Sales

Title

[Signature] July 10, 2023
Board of County Commissioners
as delegated by resolution

Approved as to form only:

[Signature]
Assistant Prosecuting Attorney

AGENDA ITEM COVER SHEET



Trustee Meeting Date:	Agenda Item Type:
November 14, 2023	Requisition Item
Submitted By:	
Arun Hindupur, Director of Public Works/Community Services	

Motion:
Rush Truck Centers of Ohio - \$58,685.00 - Purchase 2023 Ford F450 truck cab and chassis for fleet replacement (CIP 1867)

Background:
<p>At the April 25, 2023 meeting, the Board approved the purchase of a 2023 Ford F350 truck cab and chassis from Kings Ford, Inc, for \$48,225.00 as a part of the Community Services fleet replacement program. Due to an unknown lead time, Ford has cancelled this order. A 2023 Ford F450 truck cab and chassis was found for sale at Rush Truck Centers of Ohio for \$58,685.00.</p> <p>A 2003 Ford F-350 1-ton Dump Truck in our front line fleet is planned for replacement in 2023, and then it will be moved to a backup role.</p> <p>In order to complete the build for a sign truck based on Township specifications, two vendors will be utilized. Per budget discussions, we are using TIF funds for 12.5% of the cost of this truck.</p> <p>This Purchase Order will be for the cab and chassis and the Purchase Order for the upfit was approved by the Board at the September 26, 2023 meeting.</p>

Finance	Budgeted Item:	Yes; CIP, TIF		
	CIP #:	1867		
	TIF Info:	all		
	Purchase Order:	23001891	Total Encumbrance:	\$ 58,685.00

Prepared for: Doug Pyle

West Chester Township

Prepared by: Josh Huckery

11/01/2023



Rush Truck Center, Cincinnati | 11775 Highway Drive Cincinnati Ohio | 452412005

2023 F-450 Chassis 4x2 SD Regular Cab 169" WB DRW XL (F4G)

Price Level: 350 | Stock No: 1595283 | VIN: 1FDTF4GN8PDA02078 | Quote ID: F450gas4x2

Selected Equip & Specs

Dimensions

- Conventional Capacity: 17,500 lbs.
- * **Fifth-wheel towing capacity: 21,500 lbs.**
- Vehicle body length: 254.8"
- Vehicle body height: 81.5"
- Front track: 74.8"
- Vehicle turning radius: 24.2'
- Rear tire outside width: 93.9"
- Frame section modulus: 12.7 cu.in.
- Frame rail width: 34.2"
- Front bumper to back of cab: 123.7"
- Rear brake diameter: 15.8"
- Max interior rear cargo volume: 11.6 cu.ft.
- Headroom first-row: 40.8"
- Shoulder room first-row: 66.7"
- GCWR: 30,000 lbs.
- * **Gooseneck towing capacity: 21,600 lbs.**
- Vehicle body width: 80.0"
- Wheelbase: 169.0"
- Rear track: 74.0"
- Cab to axle: 84.0"
- Axle to end of frame: 47.2"
- Frame yield strength (psi): 50000.0
- Front bumper to front axle: 38.3"
- Front brake diameter: 15.4"
- Interior rear cargo volume: 11.6 cu.ft.
- Total passenger volume: 64.6 cu.ft.
- Leg room first-row: 43.9"
- Hip room first-row: 62.5"

Powertrain

- 7.3L V-8 DEVCT variable valve control, engine with 335HP
- Injection Type: sequential MPI
- Horsepower: 335 HP@3750 RPM
- Radiator
- TorqShift 10-speed automatic
- Recommended fuel: regular unleaded
- Driveline managed traction control
- Engine cylinders: V-8
- Spark ignition system
- Torque: 468 lb.-ft.@3750 RPM
- Auxiliary power take-off
- Rear-wheel drive
- * **Mechanical limited slip differential**

Fuel Economy and Emissions

- Gasoline secondary fuel type
- Federal emissions

Suspension and Handling

- Firm ride suspension
- Heavy-duty rear shock absorbers
- Heavy-duty front shock absorbers

Driveability

- 4-wheel disc brakes
- 4-wheel antilock (ABS) brakes
- Brake assist system
- Mono-beam rigid axle front suspension
- Front coil springs
- Leaf spring rear suspension
- Front and rear ventilated disc brakes
- Four channel ABS brakes
- Hill Start Assist
- Front anti-roll bar
- DANA M300 rigid axle rear suspension
- Rear anti-roll bar

Prices and content availability as shown are subject to change and should be treated as estimates only. Actual base vehicle, package and option pricing may vary from this estimate because of special local pricing, availability or pricing adjustments not reflected in the dealer's computer system. See salesperson for the most current information.

Prepared for: Doug Pyle

West Chester Township

Prepared by: Josh Huckery

11/01/2023

Rush Truck Center, Cincinnati | 11775 Highway Drive Cincinnati Ohio | 452412005



2023 F-450 Chassis 4x2 SD Regular Cab 169" WB DRW XL (F4G)

Price Level: 350 | Stock No: 1595283 | VIN: 1FDTF4GN8PDA02078 | Quote ID: F450gas4x2

Selected Equip & Specs (cont'd)

- Hydraulic power-assist steering system
- 2-wheel steering system
- Re-circulating ball steering

Body Exterior

- Trailer wiring harness
- 2 doors
- Monotone paint
- Black side window trim
- Black door handles
- * **Body-coloured front bumper rub strip**
- * **Black grille with chrome accents**
- Manual extendable trailer mirrors
- Turn signal indicator in door mirrors
- 19.5 x 6-inch front and dual rear argent steel wheels
- * **Side assist steps**
- Clearcoat paint
- Black fender flares
- Black windshield trim
- * **Chrome front bumper**
- 2 front tow hooks
- Black door mirrors
- Convex spotter in driver and passenger side door mirrors
- LT225/70RS19.5 AS BSW front and rear tires

Convenience

- Power door locks with 2 stage unlocking
- All-in-one remote fob and ignition key
- * **FordPass Connect smart device and keyfob vehicle start control**
- Power first-row windows
- Illuminated locking glove box
- Front beverage holders
- Instrument panel covered bin
- Retained accessory power
- Trip computer
- Over the air updates
- Keyfob activated door locks
- Cruise control with steering wheel mounted controls
- Day/Night rearview mirror
- Fixed rear windshield
- Illuminated glove box
- 6 beverage holders
- Dashboard storage
- PRND in IP
- Upfitter switches

Comfort

- Manual climate control
- Cloth headliner material
- Full vinyl floor covering
- Manual tilting steering wheel
- Urethane steering wheel
- Cabin air filter
- Full headliner coverage
- Full floor coverage
- Manual telescopic steering wheel

Seats and Trim

- Seating capacity: 3
- Split-bench front seat
- Front passenger seat with 4-way directional controls
- Manual front seat head restraint control
- 40-20-40 split-bench front seat
- Driver seat with 4-way directional controls
- Height adjustable front seat head restraints
- Front seat center armrest

Prices and content availability as shown are subject to change and should be treated as estimates only. Actual base vehicle, package and option pricing may vary from this estimate because of special local pricing, availability or pricing adjustments not reflected in the dealer's computer system. See salesperson for the most current information.

Prepared for: Doug Pyle

West Chester Township

Prepared by: Josh Huckery

11/01/2023



Rush Truck Center, Cincinnati | 11775 Highway Drive Cincinnati Ohio | 452412005

2023 F-450 Chassis 4x2 SD Regular Cab 169" WB DRW XL (F4G)

Price Level: 350 | Stock No: 1595283 | VIN: 1FDTF4GN8PDA02078 | Quote ID: F450gas4x2

Selected Equip & Specs (cont'd)

- Front seat armrest storage
- Manual driver seat fore/aft control
- Manual passenger seat fore/aft control
- Vinyl front seat upholstery
- Manual reclining driver seat
- Manual reclining passenger seat
- Manual driver seat lumbar

Entertainment Features

- 2 total number of 1st row displays
- Primary touchscreen display
- In-vehicle audio
- FM radio
- SYNC 4 external memory control
- Standard grade speakers
- SYNC 4 voice activated audio controls
- Wireless audio streaming
- 8 inch primary LCD display
- AM/FM stereo radio
- AM radio
- Seek scan
- Speakers number: 4
- Steering wheel mounted audio controls
- Speed sensitive volume
- Fixed audio antenna

Lighting, Visibility and Instrumentation

- Digital/analog instrumentation display
- Trip odometer
- Compass
- Driver information center
- Tachometer
- Engine/electric motor temperature gauge
- Engine hour meter
- Aero-composite headlights
- Autolamp auto on/off headlight control
- Delay-off headlights
- Variable intermittent front windshield wipers
- Illuminated entry
- Daytime running lights
- Cab clearance lights
- Fade interior courtesy lights
- Configurable instrumentation gauges
- In-radio display clock
- Exterior temperature display
- Gauge cluster display size (inches): 4.20
- Oil pressure gauge
- Transmission fluid temperature gauge
- Light tinted windows
- Halogen headlights
- Multiple enclosed headlights
- DRL preference setting
- Front reading lights
- Variable instrument panel light
- * **Front fog lights**
- Remote activated perimeter approach lighting

Technology and Telematics

- SYNC 4 911 Assist emergency SOS system via mobile device
- AppLink/Apple CarPlay and Android Auto smart device wireless mirroring
- 2 USB ports
- SYNC 4 handsfree wireless device connectivity
- FordPass Connect 4G mobile hotspot internet access

Safety and Security

- Driver front impact airbag
- Seat mounted side impact driver airbag

Prices and content availability as shown are subject to change and should be treated as estimates only. Actual base vehicle, package and option pricing may vary from this estimate because of special local pricing, availability or pricing adjustments not reflected in the dealer's computer system. See salesperson for the most current information.

Prepared for: Doug Pyle

West Chester Township

Prepared by: Josh Huckery

11/01/2023

Rush Truck Center, Cincinnati | 11775 Highway Drive Cincinnati Ohio | 452412005



2023 F-450 Chassis 4x2 SD Regular Cab 169" WB DRW XL (F4G)

Price Level: 350 | Stock No: 1595283 | VIN: 1FDTF4GN8PDA02078 | Quote ID: F450gas4x2

Selected Equip & Specs (cont'd)

- Safety Canopy System curtain first-row overhead airbags
- Seat mounted side impact front passenger airbag
- Front height adjustable seatbelts
- Remote panic alarm
- Pre-Collision Assist with Automatic Emergency Braking (AEB) forward collision mitigation
- * **Back-up alarm**
- Cancellable front passenger air bag
- 6 airbags
- SecuriLock immobilizer
- Lane Departure Warning
- * **Rear mounted camera**

Dimensions

General Weights

Curb weight	6,623 lbs.	Rear curb weight	2,901 lbs.
* GVWR	16,000 lbs.	* Payload	9,370 lbs.

Trailer Weights

* Fifth-wheel towing capacity	21,500 lbs.	* Gooseneck towing capacity	21,600 lbs.
Conventional capacity	17,500 lbs.	GCWR	30,000 lbs.

Front Weights

Front curb weight	3,722 lbs.	* GAWR front	6,000 lbs.
Axle capacity front	6,500 lbs.	* Spring rating front	6,000 lbs.
Tire/wheel capacity front	7,500 lbs.		

Rear Weights

GAWR rear	12,880 lbs.	Axle capacity rear	12,880 lbs.
Spring rating rear	12,880 lbs.	Tire/wheel capacity rear	15,000 lbs.

Off Road

Min ground clearance	8.3"
----------------------	------

Exterior Measurements

Vehicle body length	254.8"	Vehicle body width	80.0"
Vehicle body height	81.5"	Wheelbase	169.0"
Front brake diameter	15.4"	Rear brake diameter	15.8"
Rear frame height loaded	28.5"	Rear frame height unloaded	34.5"
Front track	74.8"	Rear track	74.0"
Vehicle turning radius	24.2'	Cab to axle	84.0"
Rear tire outside width	93.9"	Axle to end of frame	47.2"
Frame section modulus	12.7 cu.in.	Frame yield strength (psi)	50000.0
Frame rail width	34.2"	Front bumper to front axle	38.3"
Front bumper to back of cab	123.7"		

Interior Measurements

Interior rear cargo volume	11.6 cu.ft.	Max interior rear cargo volume	11.6 cu.ft.
----------------------------	-------------	--------------------------------	-------------

Prices and content availability as shown are subject to change and should be treated as estimates only. Actual base vehicle, package and option pricing may vary from this estimate because of special local pricing, availability or pricing adjustments not reflected in the dealer's computer system. See salesperson for the most current information.

Prepared for: Doug Pyle

West Chester Township

Prepared by: Josh Huckery

11/01/2023



Rush Truck Center, Cincinnati | 11775 Highway Drive Cincinnati Ohio | 452412005

2023 F-450 Chassis 4x2 SD Regular Cab 169" WB DRW XL (F4G)

Price Level: 350 | Stock No: 1595283 | VIN: 1FDTF4GN8PDA02078 | Quote ID: F450gas4x2

Selected Equip & Specs (cont'd)

Interior Volume

Total passenger volume 64.6 cu.ft.

Headroom

Headroom first-row 40.8"

Legroom

Leg room first-row 43.9"

Shoulder Room

Shoulder room first-row 66.7"

Hip Room

Hip room first-row 62.5"

Powertrain

Engine

Engine	7.3L V-8 DEVCT variable valve control, engine with 335HP	Valves per cylinder	2
Engine cylinders	V-8	Injection type	sequential MPI
Engine location	Front mounted engine	Ignition	Spark ignition system
Engine mounting direction	Longitudinal mounted engine	Engine block material	Iron engine block
Cylinder head material	Aluminum cylinder head		

Engine Specs

Displacement	7.3L	cc	445 cu.in.
Bore	4.21"	Stroke	3.98"
Compression ratio	10.5	SAEJ1349	AUG2004 compliant

Engine Power

Horsepower	335 HP@3750 RPM	Torque	468 lb.-ft.@3750 RPM
------------	-----------------	--------	----------------------

Alternator

Alternator amps	250A	* Alternator type	Dual alternator
* Alternator rating	150A		

Battery

* Battery amps	68Ah	* Battery type	Dual lead acid battery
Battery rating	750CCA	Battery run down protection	Battery run down protection

Engine Extras

Radiator	Radiator	Auxiliary power take-off	Auxiliary power take-off
----------	----------	--------------------------	--------------------------

Prices and content availability as shown are subject to change and should be treated as estimates only. Actual base vehicle, package and option pricing may vary from this estimate because of special local pricing, availability or pricing adjustments not reflected in the dealer's computer system. See salesperson for the most current information.

Prepared for: Doug Pyle

West Chester Township

Prepared by: Josh Huckery

11/01/2023



Rush Truck Center, Cincinnati | 11775 Highway Drive Cincinnati Ohio | 452412005

2023 F-450 Chassis 4x2 SD Regular Cab 169" WB DRW XL (F4G)

Price Level: 350 | Stock No: 1595283 | VIN: 1FDTF4GN8PDA02078 | Quote ID: F450gas4x2

Selected Equip & Specs (cont'd)

Transmission

Transmission	TorqShift 10-speed automatic	Transmission electronic control	Transmission electronic control
Overdrive transmission	Overdrive transmission	Lock-up transmission	Lock-up transmission
First gear ratio	4.615	Second gear ratio	2.919
Third gear ratio	2.132	Fourth gear ratio	1.773
Fifth gear ratio	1.519	Sixth gear ratio	1.277
Reverse gear ratio	4.695	Seventh gear ratio	1
Eighth gear ratio	0.851	Ninth gear ratio	0.687
Tenth gear ratio	0.632	Stall ratio	1.97
Selectable mode transmission	Selectable mode transmission	Sequential shift control	SelectShift Sequential shift control
Transmission oil cooler	Transmission oil cooler	PTO transmission provision	PTO transmission provision

Drive Type

Drive type Rear-wheel drive

Drivetrain

Axle ratio 4.88

Exhaust

Tailpipe Stainless steel single exhaust

Fuel

Fuel type regular unleaded

Fuel Tank

Fuel tank capacity 40.00 gal.

Drive Feature

* Limited slip differential	Mechanical limited slip differential	Traction control	Driveline managed traction control
-----------------------------	---	------------------	------------------------------------

Provisions

* Provisions **Snow plow provisions**

Fuel Economy and Emissions

Fuel Economy

Secondary fuel type Gasoline secondary fuel type

Emissions

Emissions Federal emissions

Prices and content availability as shown are subject to change and should be treated as estimates only. Actual base vehicle, package and option pricing may vary from this estimate because of special local pricing, availability or pricing adjustments not reflected in the dealer's computer system. See salesperson for the most current information.

Prepared for: Doug Pyle

West Chester Township

Prepared by: Josh Huckery

11/01/2023

Rush Truck Center, Cincinnati | 11775 Highway Drive Cincinnati Ohio | 452412005



2023 F-450 Chassis 4x2 SD Regular Cab 169" WB DRW XL (F4G)

Price Level: 350 | Stock No: 1595283 | VIN: 1FDTF4GN8PDA02078 | Quote ID: F450gas4x2

Selected Equip & Specs (cont'd)

Suspension and Handling

Suspension

Suspension	Firm ride suspension	Front shock absorbers	Heavy-duty front shock absorbers
Rear shock absorbers absorbers	Heavy-duty rear shock absorbers		

Driveability

Brakes

Brake type	4-wheel disc brakes	Ventilated brakes	Front and rear ventilated disc brakes
ABS brakes	Four channel ABS brakes	ABS brakes	4-wheel antilock (ABS) brakes

Brake Assistance

Hill start assist	Hill Start Assist	Brake assist system	Brake assist system
-------------------	-------------------	---------------------	---------------------

Front Suspension

Anti-roll bar front	Front anti-roll bar	Suspension ride type front	Mono-beam rigid axle front suspension
---------------------	---------------------	----------------------------	---------------------------------------

Front Spring

* HD front springs	Heavy-duty front springs	Springs front	Front coil springs
--------------------	--------------------------	---------------	--------------------

Rear Spring

Springs rear	Rear leaf springs	Rear springs	Heavy-duty rear springs
--------------	-------------------	--------------	-------------------------

Rear Suspension

Anti-roll bar rear	Rear anti-roll bar	Suspension type rear suspension	Leaf spring rear suspension
Suspension ride type rear	DANA M300 rigid axle rear suspension		

Steering

Steering system	Hydraulic power-assist steering	Steering type	Re-circulating ball steering
Steering type number of wheels	2-wheel steering system		

Exterior

Front Wheels

Front wheels diameter	19.5"	Front wheels width	6"
-----------------------	-------	--------------------	----

Rear Wheels

Prices and content availability as shown are subject to change and should be treated as estimates only. Actual base vehicle, package and option pricing may vary from this estimate because of special local pricing, availability or pricing adjustments not reflected in the dealer's computer system. See salesperson for the most current information.

Prepared for: Doug Pyle

West Chester Township

Prepared by: Josh Huckery

11/01/2023



Rush Truck Center, Cincinnati | 11775 Highway Drive Cincinnati Ohio | 452412005

2023 F-450 Chassis 4x2 SD Regular Cab 169" WB DRW XL (F4G)

Price Level: 350 | Stock No: 1595283 | VIN: 1FDTF4GN8PDA02078 | Quote ID: F450gas4x2

Selected Equip & Specs (cont'd)

Rear wheels diameter	19.5"	Rear wheels width	6"
<i>Front And Rear Wheels</i>			
Appearance	argent	Material	steel
<i>Front Tires</i>			
Aspect	70	Diameter	19.5"
Sidewalls	BSW	Speed	S
Tread	AS	Type	LT
Width	225mm	Front wheel - RPM	647
<i>Rear Tires</i>			
Aspect	70	Diameter	19.5"
Sidewalls	BSW	Speed	S
Tread	AS	Type	LT
Width	225mm	Rear wheel - RPM	647

Body Exterior

Trailerling

Towing wiring harness	Trailer wiring harness	Towing brake controller	Trailer brake controller
Towing trailer sway	Trailer sway control		

Exterior Features

Number of doors	2 doors	* Side steps	Side assist steps
Front splash guards	Front splash guards		

Body

Body panels Aluminum body panels with side impact beams

Mirrors

Convex spotter	Convex spotter in driver and passenger side door mirrors	Turn signal in door mirrors	Turn signal indicator in door mirrors
----------------	--	-----------------------------	---------------------------------------

Tires

Front tires LT load rating	G	Rear tires LT load rating	G
----------------------------	---	---------------------------	---

Wheels

Dual rear wheels	Dual rear wheels
------------------	------------------

Convenience

Door Locks

Door locks unlocking	Power door locks with 2 stage	Keyfob door locks	Keyfob activated door locks
----------------------	-------------------------------	-------------------	-----------------------------

Prices and content availability as shown are subject to change and should be treated as estimates only. Actual base vehicle, package and option pricing may vary from this estimate because of special local pricing, availability or pricing adjustments not reflected in the dealer's computer system. See salesperson for the most current information.

Prepared for: Doug Pyle

West Chester Township

Prepared by: Josh Huckery

11/01/2023



Rush Truck Center, Cincinnati | 11775 Highway Drive Cincinnati Ohio | 452412005

2023 F-450 Chassis 4x2 SD Regular Cab 169" WB DRW XL (F4G)

Price Level: 350 | Stock No: 1595283 | VIN: 1FDTF4GN8PDA02078 | Quote ID: F450gas4x2

Selected Equip & Specs (cont'd)

All-in-one key All-in-one remote fob and ignition key

Cruise Control

Cruise control Cruise control with steering wheel mounted controls

Key Fob Controls

* Fob remote vehicle controls **FordPass Connect smart device and keyfob vehicle start control**

Rear View Mirror

Day/Night rearview mirror Day/Night rearview mirror

Exterior Mirrors

Door mirrors Power door mirrors Folding door mirrors Manual folding door mirrors
Heated door mirrors Heated driver and passenger side door mirrors

Front Side Windows

First-row windows Power first-row windows

Overhead Console

Overhead console Full overhead console Overhead console storage Overhead console storage

Passenger Visor

Visor passenger mirror Passenger visor mirror

Power Outlets

12V power outlets 2 12V power outlets * 120V AC power outlets 2 120V AC power outlets

Rear Windshield

Rear windshield Fixed rear windshield

Storage

Number of beverage holders 6 beverage holders Beverage holders Front beverage holders
Glove box Illuminated locking glove box Illuminated glove box
Instrument panel storage Instrument panel covered bin Dashboard storage Dashboard storage

Windows Feature

One-touch up window Driver and passenger one-touch up windows One-touch down window Driver and passenger one-touch down windows

Prices and content availability as shown are subject to change and should be treated as estimates only. Actual base vehicle, package and option pricing may vary from this estimate because of special local pricing, availability or pricing adjustments not reflected in the dealer's computer system. See salesperson for the most current information.

Prepared for: Doug Pyle

West Chester Township

Prepared by: Josh Huckery

11/01/2023



Rush Truck Center, Cincinnati | 11775 Highway Drive Cincinnati Ohio | 452412005

2023 F-450 Chassis 4x2 SD Regular Cab 169" WB DRW XL (F4G)

Price Level: 350 | Stock No: 1595283 | VIN: 1FDTF4GN8PDA02078 | Quote ID: F450gas4x2

Selected Equip & Specs (cont'd)

Miscellaneous

Trip computer
Upfitter switches
Over the air updates

Trip computer
Upfitter switches
Over the air updates

PRND in IP
Accessory power

PRND in IP
Retained accessory power

Comfort

Climate Control

Climate control Manual climate control

Cabin air filter Cabin air filter

Headliner

Headliner material Cloth headliner material Headliner coverage Full headliner coverage

Floor Trim

Floor covering Full vinyl floor covering Floor coverage Full floor coverage

Steering Wheel

Steering wheel telescopic steering wheel Manual telescopic steering wheel Steering wheel material Urethane steering wheel
Steering wheel tilt Manual tilting steering wheel

Seats and Trim

Seat Capacity

Seating capacity 3

Front Seats

Front seat type Split-bench front seat Driver seat direction Driver seat with 4-way directional controls
Driver seat fore/aft control Manual driver seat fore/aft control Passenger seat direction Front passenger seat with 4-way directional controls
Split front seats 40-20-40 split-bench front seat Reclining passenger seat Manual reclining passenger seat
Passenger seat fore/aft control Manual passenger seat fore/aft control Front head restraints Height adjustable front seat head restraints
Front head restraint control Manual front seat head restraint control Armrests front center Front seat center armrest
Armrests front storage Front seat armrest storage Reclining driver seat Manual reclining driver seat

Lumbar Seats

Driver lumbar Manual driver seat lumbar

Front Seat Trim

Front seat upholstery Vinyl front seat upholstery Front seatback upholstery Vinyl front seatback upholstery

Prices and content availability as shown are subject to change and should be treated as estimates only. Actual base vehicle, package and option pricing may vary from this estimate because of special local pricing, availability or pricing adjustments not reflected in the dealer's computer system. See salesperson for the most current information.

Prepared for: Doug Pyle

West Chester Township

Prepared by: Josh Huckery

11/01/2023



Rush Truck Center, Cincinnati | 11775 Highway Drive Cincinnati Ohio | 452412005

2023 F-450 Chassis 4x2 SD Regular Cab 169" WB DRW XL (F4G)

Price Level: 350 | Stock No: 1595283 | VIN: 1FDTF4GN8PDA02078 | Quote ID: F450gas4x2

Selected Equip & Specs (cont'd)

Interior Accents

Interior accents Chrome interior accents

Gearshifter Material

Gearshifter material Urethane gear shifter material

Entertainment Features

LCD Displays

Primary touchscreen display Primary touchscreen display Number of first-row LCD displays 2 total number of 1st row displays
LCD primary display size 8 inch primary LCD display

Radio Features

External memory control SYNC 4 external memory Seek scan Seek scan

Speakers

Speakers Standard grade speakers Speakers number 4

Audio Features

Steering mounted audio control Steering wheel mounted audio controls Speed sensitive volume Speed sensitive volume
Voice activated audio SYNC 4 voice activated audio controls Wireless streaming Wireless audio streaming

Lighting, Visibility and Instrumentation

Instrumentation

Trip odometer Trip odometer Instrumentation display Digital/analog instrumentation display
Configurable instrumentation gauges Configurable instrumentation gauges

Instrumentation Displays

Temperature display Exterior temperature display Driver information center Driver information center
Clock In-radio display clock Compass Compass

Instrumentation Gauges

Tachometer Tachometer Oil pressure gauge Oil pressure gauge
Transmission temperature gauge Transmission fluid temperature gauge Engine/electric motor temperature gauge Engine/electric motor temperature gauge

Prices and content availability as shown are subject to change and should be treated as estimates only. Actual base vehicle, package and option pricing may vary from this estimate because of special local pricing, availability or pricing adjustments not reflected in the dealer's computer system. See salesperson for the most current information.

Prepared for: Doug Pyle

West Chester Township

Prepared by: Josh Huckery

11/01/2023



Rush Truck Center, Cincinnati | 11775 Highway Drive Cincinnati Ohio | 452412005

2023 F-450 Chassis 4x2 SD Regular Cab 169" WB DRW XL (F4G)

Price Level: 350 | Stock No: 1595283 | VIN: 1FDTF4GN8PDA02078 | Quote ID: F450gas4x2

Selected Equip & Specs (cont'd)

Gauge cluster display size (inches) 4.20

Engine hour meter

Engine hour meter

Instrumentation Warnings

Engine temperature warning Engine temperature warning

Oil pressure warning

Oil pressure warning

Low fuel warning Low fuel warning

Low brake fluid warning

Low brake fluid warning

Battery charge warning Battery charge warning

Headlights on reminder

Headlights on reminder

Key in vehicle warning Key in vehicle warning

Door ajar warning

Door ajar warning

Service interval warning Service interval indicator

Glass

Tinted windows

Light tinted windows

Headlights

Headlights

Halogen headlights

Headlight type

Aero-composite headlights

Auto headlights Autolamp auto on/off headlight control

Multiple headlights Multiple enclosed headlights

Delay off headlights

Delay-off headlights

DRL preference setting

DRL preference setting

Front Windshield

Wipers Variable intermittent front windshield wipers

Interior Lighting

Illuminated entry

Illuminated entry

Variable panel light

Variable instrument panel light

Front reading lights

Front reading lights

Lights

Running lights

Daytime running lights

Interior courtesy lights

Fade interior courtesy lights

*** Fog lights**

Front fog lights

Clearance lights

Cab clearance lights

Perimeter approach lighting

Remote activated

perimeter approach lighting

Technology and Telematics

Connectivity

Handsfree SYNC 4 handsfree wireless device connectivity

Smart device integration AppLink/Apple CarPlay and Android Auto smart device wireless mirroring

Emergency SOS

SYNC 4 911 Assist

emergency SOS system via mobile device

Internet Access

Prices and content availability as shown are subject to change and should be treated as estimates only. Actual base vehicle, package and option pricing may vary from this estimate because of special local pricing, availability or pricing adjustments not reflected in the dealer's computer system. See salesperson for the most current information.

Prepared for: Doug Pyle

West Chester Township

Prepared by: Josh Huckery

11/01/2023



Rush Truck Center, Cincinnati | 11775 Highway Drive Cincinnati Ohio | 452412005

2023 F-450 Chassis 4x2 SD Regular Cab 169" WB DRW XL (F4G)

Price Level: 350 | Stock No: 1595283 | VIN: 1FDTF4GN8PDA02078 | Quote ID: F450gas4x2

Selected Equip & Specs (cont'd)

Internet access FordPass Connect 4G mobile hotspot internet access

USB Ports

USB ports 2 USB ports

Safety and Security

Airbags

Front impact airbag driver airbag	Driver front impact airbag	Number of airbags	6 airbags
Front impact airbag passenger air bag	Cancellable front passenger air bag	Front side impact airbag driver impact driver airbag	Seat mounted side impact driver airbag
Front side impact airbag passenger side impact front passenger airbag	Seat mounted side impact front passenger airbag	Overhead airbags curtain first-row overhead airbags	Safety Canopy System

Seatbelts

Height adjustable seatbelts Front height adjustable seatbelts

Security System

Immobilizer SecuriLock immobilizer Remote panic alarm Remote panic alarm

Active Driving Assistance

Lane departure Lane Departure Warning Forward collision warning with Automatic Emergency Braking (AEB) forward collision mitigation Pre-Collision Assist

Cameras

* Rear camera Rear mounted camera

Parking Sensors

* Back up alarm Back-up alarm

Prices and content availability as shown are subject to change and should be treated as estimates only. Actual base vehicle, package and option pricing may vary from this estimate because of special local pricing, availability or pricing adjustments not reflected in the dealer's computer system. See salesperson for the most current information.

Prepared for: Doug Pyle

West Chester Township

Prepared by: Josh Huckery

11/01/2023



Rush Truck Center, Cincinnati | 11775 Highway Drive Cincinnati Ohio | 452412005

2023 F-450 Chassis 4x2 SD Regular Cab 169" WB DRW XL (F4G)

Price Level: 350 | Stock No: 1595283 | VIN: 1FDTF4GN8PDA02078 | Quote ID: F450gas4x2

As Configured Vehicle

Code	Description
Base Vehicle	
F4G	Base Vehicle Price (F4G)
Packages	
650A	<p>Order Code 650A</p> <p><i>Includes:</i></p> <ul style="list-style-type: none"> - Engine: 7.3L 2V DEVCT NA PFI V8 Gas - Transmission: TorqShift 10-Speed Automatic 10R140 with neutral idle. Includes SelectShift and selectable drive modes: normal, tow/haul, eco, slippery roads and trail. - Tires: 225/70Rx19.5G BSW A/P - Wheels: 19.5" x 6" Argent Painted Steel Hub covers/center ornaments not included. - HD Vinyl 40/20/40 Split Bench Seat Includes center armrest, cupholder, storage, 2-way adjustable driver/passenger headrests and driver's side manual lumbar. - Radio: AM/FM Stereo w/MP3 Player Includes 4 speakers. - SYNC 4 Communications & Entertainment System Includes enhanced voice recognition, 911 Assist, 8" LCD center stack screen, AppLink, 1 smart-charging USB port and trailer brake controller.
Powertrain	
99N	Engine: 7.3L 2V DEVCT NA PFI V8 Gas
44G	<p>Transmission: TorqShift 10-Speed Automatic</p> <p><i>10R140 with neutral idle. Includes SelectShift and selectable drive modes: normal, tow/haul, eco, slippery roads and trail.</i></p>
X8L	Limited Slip w/4.88 Axle Ratio
68L	GVWR: 16,000 lb Payload Package
Wheels & Tires	
TGJ	Tires: 225/70Rx19.5G BSW A/P
64Z	<p>Wheels: 19.5" x 6" Argent Painted Steel</p> <p><i>Hub covers/center ornaments not included.</i></p>
Seats & Seat Trim	
A	<p>HD Vinyl 40/20/40 Split Bench Seat</p> <p><i>Includes center armrest, cupholder, storage, 2-way adjustable driver/passenger headrests and driver's side manual lumbar.</i></p>
Other Options	

Prices and content availability as shown are subject to change and should be treated as estimates only. Actual base vehicle, package and option pricing may vary from this estimate because of special local pricing, availability or pricing adjustments not reflected in the dealer's computer system. See salesperson for the most current information.

Prepared for: Doug Pyle

West Chester Township

Prepared by: Josh Huckery

11/01/2023



Rush Truck Center, Cincinnati | 11775 Highway Drive Cincinnati Ohio | 452412005

2023 F-450 Chassis 4x2 SD Regular Cab 169" WB DRW XL (F4G)

Price Level: 350 | Stock No: 1595283 | VIN: 1FDTF4GN8PDA02078 | Quote ID: F450gas4x2

As Configured Vehicle (cont'd)

Code	Description
PAINT	Monotone Paint Application
169WB	169" Wheelbase
STDRD	Radio: AM/FM Stereo w/MP3 Player <i>Includes 4 speakers.</i> <i>Includes:</i> - SYNC 4 Communications & Entertainment System - Includes enhanced voice recognition, 911 Assist, 8" LCD center stack screen, AppLink, 1 smart-charging USB port and trailer brake controller.
96V	XL Chrome Package <i>Includes:</i> - Chrome Front Bumper - Bright Grille - Remote Start - Halogen Fog Lamps
473	Snow Plow Prep Package <i>Includes pre-selected springs (see order guide supplemental reference for springs/FGAWR of specific vehicle configurations). Note 1: Restrictions apply; see supplemental reference or body builders layout book for details. Note 2: Also allows for the attachment of a winch. Note 3: Highly recommended to add (86M) dual battery on 7.3L gas engine. Adding (67B) 410 amp dual alternators for diesel engine is highly recommended for max power output.</i>
18Y	Ford Pro Upfit Integration System Removal
43K	Pro Power Onboard - 2kW <i>Includes dual alternators 12V 250 Amp + 24V 150 Amp. Placement and connection of the aux outlet is the responsibility of the final stage manufacturer.</i>
86M	Dual 68 AH/65 AGM Battery
18B	Platform Running Boards
872	Rear View Camera & Prep Kit <i>Pre-installed content includes cab wiring and frame wiring to the rear most cross member. Upfitters kit includes camera with mounting bracket, 20' jumper wire and camera mounting/aiming instructions.</i>
76C	Exterior Backup Alarm (Pre-Installed)

Fleet Options

WARANT	Fleet Customer Powertrain Limited Warranty Requires valid FIN code.
--------	--

Prices and content availability as shown are subject to change and should be treated as estimates only. Actual base vehicle, package and option pricing may vary from this estimate because of special local pricing, availability or pricing adjustments not reflected in the dealer's computer system. See salesperson for the most current information.

Prepared for: Doug Pyle

West Chester Township

Prepared by: Josh Huckery

11/01/2023



Rush Truck Center, Cincinnati | 11775 Highway Drive Cincinnati Ohio | 452412005

2023 F-450 Chassis 4x2 SD Regular Cab 169" WB DRW XL (F4G)

Price Level: 350 | Stock No: 1595283 | VIN: 1FDTF4GN8PDA02078 | Quote ID: F450gas4x2

As Configured Vehicle (cont'd)

Code	Description
Emissions	<i>Ford is increasing the 5-year 60,000-mile limited powertrain warranty to 5-years, 100,000 miles. Only Fleet purchasers with a valid Fleet Identification Number (FIN code) will receive the extended warranty. When the sale is entered into the sales reporting system with a sales type fleet along with a valid FIN code, the warranty extension will automatically be added to the vehicle. The extension will stay with the vehicle even if it is subsequently sold to a non-fleet customer before the expiration. This extension applies to both gas and diesel powertrains. Dealers can check for the warranty extension on eligible fleet vehicles in OASIS. Please refer to the Warranty and Policy Manual section 3.13.00 Gas Engine Commercial Warranty. This change will also be reflected in the printed Warranty Guided distributed with the purchase of every new vehicle.</i>
425	50-State Emissions System
Exterior Color	
Z1_01	Oxford White
Interior Color	
AS_03	Medium Dark Slate w/HD Vinyl 40/20/40 Split Bench Seat

Prices and content availability as shown are subject to change and should be treated as estimates only. Actual base vehicle, package and option pricing may vary from this estimate because of special local pricing, availability or pricing adjustments not reflected in the dealer's computer system. See salesperson for the most current information.

Prepared for: Doug Pyle

West Chester Township

Prepared by: Josh Huckery

11/01/2023



Rush Truck Center, Cincinnati | 11775 Highway Drive Cincinnati Ohio | 452412005

2023 F-450 Chassis 4x2 SD Regular Cab 169" WB DRW XL (F4G)

Price Level: 350 | Stock No: 1595283 | VIN: 1FDTF4GN8PDA02078 | Quote ID: F450gas4x2

Warranty

Standard Warranty

Basic Warranty

Basic warranty

36 months/36,000 miles

Powertrain Warranty

Powertrain warranty

60 months/60,000 miles

Corrosion Perforation

Corrosion perforation warranty

60 months/unlimited

Roadside Assistance Warranty

Roadside warranty

60 months/60,000 miles

Prices and content availability as shown are subject to change and should be treated as estimates only. Actual base vehicle, package and option pricing may vary from this estimate because of special local pricing, availability or pricing adjustments not reflected in the dealer's computer system. See salesperson for the most current information.

Prepared for: Doug Pyle

West Chester Township

Prepared by: Josh Huckery

11/01/2023

Rush Truck Center, Cincinnati | 11775 Highway Drive Cincinnati Ohio | 452412005



2023 F-450 Chassis 4x2 SD Regular Cab 169" WB DRW XL (F4G)

Price Level: 350 | Stock No: 1595283 | VIN: 1FDTF4GN8PDA02078 | Quote ID: F450gas4x2

Vehicle Dimension and Performance Summary

Performance predictions in this report represent an estimate of vehicle performance based on standard operating conditions. Variations in customer equipment, load configuration, ambient conditions, and/or operator driving techniques can cause significant variations in vehicle performance. These values are not representative of results that may be shown in actual dynamometer tests. This report should therefore be used as a guide for comparative vehicle performance.

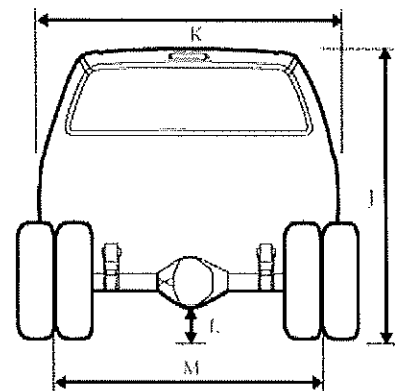
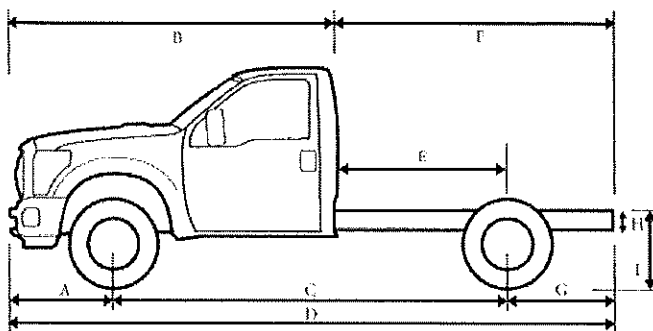

Dimensions

A	Front of Bumper to Front Axle	38.30 in.
B	Front Bumper to Back of Cab (BBC)	123.70 in.
C	Wheelbase (WB)	169.00 in.
D	Overall Length (OAL)	254.80 in.
E	Back of Cab to Rear Axle (CA)	84.00 in.
F	Back of Cab to End of Frame	131.20 in.
G	Rear Axle to End of Frame (AF)	47.20 in.
H	Frame Section Height	N/A
I	Rear Frame Height Unloaded	34.50 in.
I	Rear Frame Height Loaded	28.50 in.
J	Cab Height	81.50 in.
K	Body Width	80.00 in.
L	Maximum Ground Clearance	N/A
L	Minimum Ground Clearance	8.30 in.
M	Front Tread	74.80 in.
M	Rear Tread	74.00 in.

Prices and content availability as shown are subject to change and should be treated as estimates only. Actual base vehicle, package and option pricing may vary from this estimate because of special local pricing, availability or pricing adjustments not reflected in the dealer's computer system. See salesperson for the most current information.

Prepared for: Doug Pyle

West Chester Township

Prepared by: Josh Huckery

11/01/2023



Rush Truck Center, Cincinnati | 11775 Highway Drive Cincinnati Ohio | 452412005

2023 F-450 Chassis 4x2 SD Regular Cab 169" WB DRW XL (F4G)

Price Level: 350 | Stock No: 1595283 | VIN: 1FDTF4GN8PDA02078 | Quote ID: F450gas4x2

Vehicle Dimension and Performance Summary (cont'd)

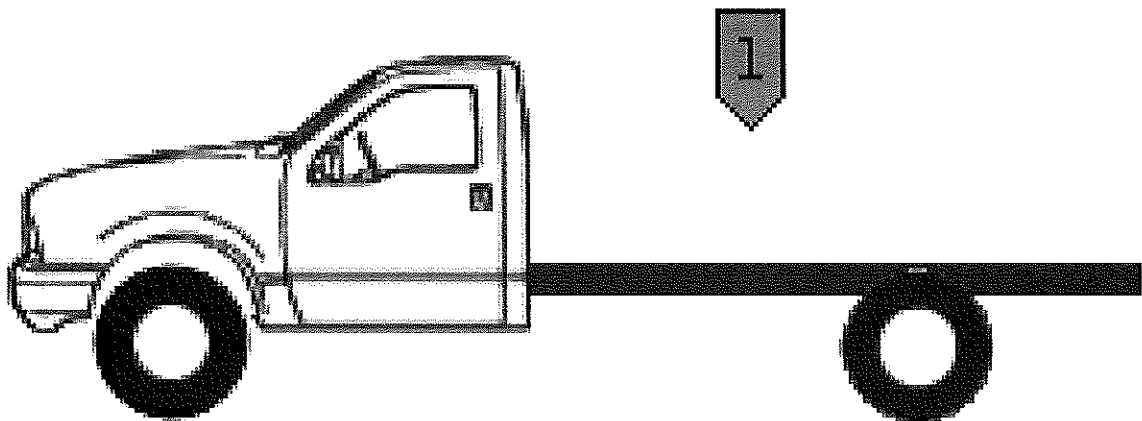

Weight

GVW	Front Axle	Rear Axle	Totals
Chassis	3,722 lbs	2,901 lbs	6,623 lbs
Body	0 lbs	0 lbs	0 lbs
Occupants Weight	300 lbs	150 lbs	450 lbs
1 Max Payload - (Max Payload)	1,978 lbs	6,949 lbs	8,927 lbs
TOTAL	6,000 lbs	10,000 lbs	16,000 lbs

Ratings	Front Axle	Rear Axle	GVWR
GAWR	6,000 lbs	12,880 lbs	16,000 lbs
Wheels/Tires	7,500 lbs	15,000 lbs	
Suspension	6,000 lbs	12,880 lbs	
Axle	6,500 lbs	12,880 lbs	
Legal Axle Limit	0 lbs	0 lbs	

Prices and content availability as shown are subject to change and should be treated as estimates only. Actual base vehicle, package and option pricing may vary from this estimate because of special local pricing, availability or pricing adjustments not reflected in the dealer's computer system. See salesperson for the most current information.

Prepared for: Doug Pyle

West Chester Township

Prepared by: Josh Huckery

11/01/2023

Rush Truck Center, Cincinnati | 11775 Highway Drive Cincinnati Ohio | 452412005



2023 F-450 Chassis 4x2 SD Regular Cab 169" WB DRW XL (F4G)

Price Level: 350 | Stock No: 1595283 | VIN: 1FDTF4GN8PDA02078 | Quote ID: F450gas4x2

Vehicle Dimension and Performance Summary (cont'd)*Start, Grade and Speed*

Start	Ratio	Desired	Calculated
Start grade capability in 1st gear	4.62	15.00 %	39.24 %
Start grade capability in reverse	4.70	15.00 %	39.92 %
Grade	Ratio	Desired	Calculated
Maximum grade in 8th gear	0.85	3.00 %	7.35 %
Maximum grade in 9th gear	0.69	3.00 %	5.93 %
Maximum grade in 10th gear	0.63	3.00 %	5.45 %
Speed		Desired	Calculated
Top Speed (level grade)		75 mph	113 mph
<i>To meet your requirement you need a maximum axle ratio of 8.80</i>			
Top Speed on 3% grade		55 mph	
<i>To meet your requirement you need a maximum of 106 hp</i>			
Cruise Speed		60 mph	78 mph
Engine RPM at desired cruise speed			1,995 rpm

*Variables in Use**Start*

Rear axle ratio:	4.88	Clutch engagement torque:	234 ft.lbs.
Tire size:	225/70R19.5 (647 rev/mile)	Torque conversion ratio:	1.97
Gross Vehicle Weight (GVW):	16,000 lbs		

Grade

Rear axle ratio:	4.88	Gross Vehicle Weight (GVW):	16,000 lbs
Tire size:	225/70R19.5 (647 rev/mile)	Peak engine torque:	468 ft.lbs.

Speed

Engine Power:	335 hp @ 3,750 rpm	Worst road surface	Typical Highway
Peak Torque RPM:	3,750 rpm	Final Drive Ratio:	0.63
Frontal Area:	40.28 Sq.Ft.	Drag Coefficient	0.80
Cruising RPM	2,600 rpm		

Prices and content availability as shown are subject to change and should be treated as estimates only. Actual base vehicle, package and option pricing may vary from this estimate because of special local pricing, availability or pricing adjustments not reflected in the dealer's computer system. See salesperson for the most current information.

Prepared for: **Doug Pyle**

West Chester Township

Prepared by: Josh Huckery

11/01/2023

Rush Truck Center, Cincinnati | 11775 Highway Drive Cincinnati Ohio | 452412005



2023 F-450 Chassis 4x2 SD Regular Cab 169" WB DRW XL (F4G)

Price Level: 350 | Stock No: 1595283 | VIN: 1FDTF4GN8PDA02078 | Quote ID: F450gas4x2

Vehicle Dimension and Performance Summary (cont'd)

Turning Radius

Turning Radius

24.25 ft

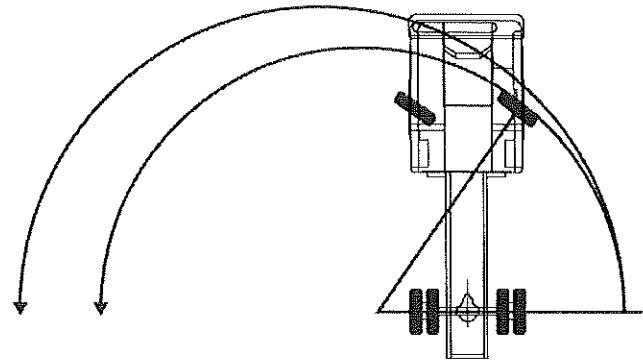

Prices and content availability as shown are subject to change and should be treated as estimates only. Actual base vehicle, package and option pricing may vary from this estimate because of special local pricing, availability or pricing adjustments not reflected in the dealer's computer system. See salesperson for the most current information.

AGENDA ITEM COVER SHEET



Trustee Meeting Date:	Agenda Item Type:
November 14, 2023	Requisition Item
Submitted By:	
Arun Hindupur, Director of Public Works/Community Services	

Motion:
Univar Solutions USA, Inc. - \$18,000.00 - Purchase calcium chloride for 2023-2024 winter season

Background:																		
<p>Community Services is preparing for winter weather and is requesting to open a Purchase Order to Univar USA, Inc. to purchase calcium chloride. The price for this snow season is \$1.357 per gallon on a 4,000 gallon delivery which is an increase over last year. The Division budgeted \$26,000.00 for calcium chloride in 2023.</p> <table border="1"> <thead> <tr> <th>Year</th> <th>Price (\$/gallon)</th> </tr> </thead> <tbody> <tr> <td>2015</td> <td>\$0.805</td> </tr> <tr> <td>2016</td> <td>\$0.84</td> </tr> <tr> <td>2017</td> <td>\$0.92</td> </tr> <tr> <td>2018</td> <td>\$0.965</td> </tr> <tr> <td>2019</td> <td>\$0.965</td> </tr> <tr> <td>2020</td> <td>\$1.04</td> </tr> <tr> <td>2021</td> <td>\$1.286</td> </tr> <tr> <td>2022</td> <td>\$1.257</td> </tr> </tbody> </table> <p>Community Services uses calcium chloride to pre-wet road salt at temperatures below 25 degrees. We use salt brine to pre-wet at temperatures above 25 degrees, however the temperatures below 25 degrees make the brine ineffective. Calcium chloride has proven quite effective as a substitute for brine when pre-wetting road salt at temperatures below 25 degrees.</p> <p>The Community Services Department is requesting a Purchase Order in the amount of \$18,000.00 for the purchase of calcium chloride during the 2023-2024 winter season.</p>	Year	Price (\$/gallon)	2015	\$0.805	2016	\$0.84	2017	\$0.92	2018	\$0.965	2019	\$0.965	2020	\$1.04	2021	\$1.286	2022	\$1.257
Year	Price (\$/gallon)																	
2015	\$0.805																	
2016	\$0.84																	
2017	\$0.92																	
2018	\$0.965																	
2019	\$0.965																	
2020	\$1.04																	
2021	\$1.286																	
2022	\$1.257																	

Finance	Budgeted Item:	Yes; Operational	
	CIP #:		
	TIF Info:		
	Purchase Order:	23001946	Total Encumbrance:

Laura Groff

From: Jim Rigsby
Sent: Thursday, October 19, 2023 2:22 PM
To: Laura Groff; Danielle Gleason
Subject: FW: Cal Chloride 32% - UNIVAR Solutions

Calcium price.

From: Doug Thorp <doug.thorp@univarsolutions.com>
Sent: Thursday, October 19, 2023 1:36 PM
To: Jim Rigsby <jrigsby@WestChesterOH.Org>; Brian Adkins <badkins@WestChesterOH.Org>
Subject: RE: Cal Chloride 32% - UNIVAR Solutions

\$1.357 / Gallon sir.....

Doug Thorp

Sales Account Manager II

Univar Solutions

P: 513-515-2366

M: 513-515-2366

Follow us on:



From: Jim Rigsby <jrigsby@WestChesterOH.Org>
Sent: Thursday, October 19, 2023 1:33 PM
To: Doug Thorp <doug.thorp@univarsolutions.com>; Brian Adkins <badkins@WestChesterOH.Org>
Subject: RE: Cal Chloride 32% - UNIVAR Solutions

CAUTION: EXTERNAL EMAIL - Do not click links or open attachments unless you recognize the sender and know the content is safe.

Doug can you revise me a price for calcium chloride.

Thanks

Jim Rigsby

Superintendent- Community Services

9577 Beckett Rd.

Suite 900

West Chester, OH 45069

jrigsby@westchesteroh.org

T: 513-777-8765

W: westchesteroh.org

AGENDA ITEM COVER SHEET



Trustee Meeting Date:	Agenda Item Type:
November 14, 2023	Personnel Item
Submitted By:	
Colonel Joel M. Herzog, Chief of Police	

Motion:
Hire Cassie Csendes to the position of Police Officer effective February 5, 2024 at the bi-weekly rate of \$2,713.97

Background:
<p>The West Chester Police Department would like to request the Trustees’ approval to hire Cassie Csendes as a full-time police officer. The hiring of Cassie Csendes will fill one police officer vacancy.</p> <p>Cassie Csendes is a certified EMT/paramedic and looking to develop her experience in public service. Law enforcement is part of her family; her husband has served five years as an officer, currently with West Chester Police. Cassie is looking forward to starting her law enforcement career. She will attend the Ohio State Highway Patrol Police Academy that begins on February 12, 2024.</p> <p>Cassie Csendes effective date of hire will be February 5, 2024, at the bi-weekly rate of \$2,713.97 with a one-year probationary period.</p> <p>Thank you for your consideration.</p>

Finance	Budgeted Item:	N/A;		
	CIP #:			
	TIF Info:			
	Purchase Order:		Total Encumbrance:	\$.00



**WEST CHESTER TOWNSHIP
ADMINISTRATION**

9113 Cincinnati-Dayton Road
West Chester, OH 45069-3840

T | 513-777-5900
F | 513-779-9369

westchesteroh.org

November 8, 2023

Cassie Csendes

Dear Cassie,

I am pleased to make a final offer of employment for the position of Police Officer for West Chester Township. Although your official appointment will be November 14, 2023 at a regular West Chester Board of Trustees' meeting, your effective hire date will be February 5th, 2024. The commitment to you regarding compensation, benefits, and related provisions is outlined herein.

General

Position:	Police Officer
Employer:	West Chester Township
Effective Hire Date:	February 5 th , 2024
Probationary Period:	Three hundred sixty-five (365) calendar days from the first day that Employee reports to work as a certified peace officer.

Compensation

Base Salary:	\$70,563.23 (Step 1) Annually
--------------	-------------------------------

Benefits/Other Provisions

Medical/Dental/Vision:	Employee may elect to receive medical benefits unless benefits can be or are currently obtained elsewhere. If eligible, plan options are currently offered with employee premium share currently at 15% or 17% for medical. The plan options and employee premium share are subject to Employer discretion.
------------------------	---

Insurance Waiver:	Employee may elect to receive a \$2,000 annual stipend in lieu of Employer-offered medical coverage.
-------------------	--

Voluntary Insurance(s)	Available at Employee cost; coverage may be elected even if medical insurance is denied.
------------------------	--

Pension:	Employee and Employer shares as determined by Ohio Public Employee Retirement System
----------	--

Deferred Compensation:	Plan provided at current federal maximum contribution.
------------------------	--

Leave: Vacation: As granted to all full-time contract employees after successful completion of probationary period;
Holidays Ten established holidays
Personal Three (3) days annually
Sick Ten hours accrued monthly;
Please refer to the current FOP Collective Bargaining Agreement

Retention Pay At Employer's discretion, one hundred dollars per year after five years of continuous service

Life Insurance: At Employer's discretion and as provided to other Employees - currently \$50,000 term life per Collective Bargaining Agreement

Disability: As provided under Public Employee Retirement System.

Performance Merit Increase: Please refer to the current FOP Collective Bargaining Agreement

Professional Development: As budgetary circumstances permit and when approved at the discretion of the Police Chief.

If you have any questions or need clarification on any item regarding the compensation package, please contact Danielle Klekamp at 513-759-7217 or email at dklekamp@westchesteroh.org.

Sincerely,



Larry D. Burks
Township Administrator

cc: Chief Herzog

AGENDA ITEM COVER SHEET



Trustee Meeting Date:	Agenda Item Type:
November 14, 2023	Business Item
Submitted By:	
Larry D. Burks, Township Administrator	

Motion:
Motion to apply for Ohio Township Association Risk Management Authority (OTARMA) MORE Grant; and, authorize Township Administrator to accept said grant if awarded

Background:
<p>Since 2013, the OTARMA Board of Directors has offered a loss control and risk management initiative called a MORE Grant (Managing Ohio Risk Exposures) to assist Ohio Townships in eliminating or preventing risk exposures that lead to liability claims and property losses.</p> <p>The MORE grant is up to \$500 in any given year for purchases made between January 1 and December 31. Applicants must be an OTARMA Member both at the time of submission and issuance of the grant funds. Approved funds will be issued once membership is verified.</p> <p>The funds are available for purchases or expenses incurred during the application period. Examples of qualified expenses include, but are not limited to:</p> <ul style="list-style-type: none"> • Playground surface materials • Automated External Defibrillators • Safety signage • Fire extinguishers • Safety cones or other hazard warning items • Life jackets <p>The West Chester Fire, Police and Services departments propose to purchase safety cones to assist with traffic and/or pedestrian control during events, hazards and emergencies.</p> <p>There are no fees, matching funds or any other expense to the Township in applying or receiving the grant. If the Board authorizes the application for the grant, the Township must purchase the cones and provide the receipt to OTARMA for an award up to \$500 toward the purchase.</p>

Finance	Budgeted Item:	N/A;		
	CIP #:			
	TIF Info:			
	Purchase Order:		Total Encumbrance:	\$.00

2023 **MORE** Grant Program

	Ohio Township Association Risk Management Authority	0001
		<u>2023</u>
PAY TO THE ORDER OF	Any OTARMA Member	\$ 500.00
Five Hundred Dollars and 00/100		DOLLARS
MEMO	MORE Grant Program	<i>OTARMA Board of Directors</i>

OTARMA - Investing in the Safety of its Members

The OTARMA Board of Directors is pleased to announce the continuation of the risk control and risk management initiative - **MORE** Grant

Since 2013, the **MORE** (**M**anaging **O**hio **R**isk **E**xposures) Grant has been assisting Ohio townships in eliminating or preventing risk exposures that lead to liability claims and property losses.

Program Details

The **MORE** Grant Program is only available to OTARMA Members. All members are encouraged to participate and apply for a grant during the application period January 1 - December 31, 2023. Applications that are incomplete or are not submitted within the required time frame may be deemed ineligible. Each applicant must be an OTARMA Member both at the time of submission and issuance of the grant funds. Approved funds will be issued once membership is verified.

Only qualified expenses will be considered for **MORE** Grant funds. Qualified expenses include safety equipment purchases, Ohio Township Association (OTA) Annual Conference registration fees, costs associated with fulfilling risk control recommendations, and risk management training or education fees. The primary purpose of the purchase is the prevention or reduction of liability claims or property losses.

The funds are available for purchases or expenses incurred during the application period.

Examples of qualified expenses include, but are not limited to:

- Playground surface materials
- Safety signage
- Safety cones or other hazard warning items
- Automated External Defibrillators
- Fire extinguishers
- Life jackets
- Hand sanitizers, masks, gloves

NEW! ⇨ • OTA Township Education Subscription

The **MORE** Grant Program has a brief application that may be found on the **OTARMA** Website at www.OTARMA.org or by contacting Wendy French at (888) 748-7966, ext. 3136 or via email at wfrench@bfgroup.com.



2023 **MORE** Grant Program Application

Please complete this simple form to apply for a MORE Grant:

Township West Chester Township

County Butler County

Contact Jenna Whittaker

Title Executive Assistant

Address 9113 Cincinnati Dayton Road

E-mail jwhittaker@westchesteroh.org

Phone Number 513-777-5900

Amount Requested
(\$500 maximum) \$500

What specifically will the **MORE** Grant funds be used for? (Please provide a brief description)

OTA Conference Registration Fees Only

Training Seminar/Education

Safety Equipment

Personal Protective Equipment (PPE)

NEW! - OTA Township Education Subscription

Briefly describe how this grant will help prevent or reduce liability claims or property losses:

The West Chester Police, Fire and Services Departments purchase safety cones

to assist with traffic and/or pedestrian control during events, hazards and emergencies.

A township must be an **OTARMA** Member at time of submission and issuance of grant funds.

MORE Grant applications must be received by December 31, 2023. Submissions are accepted via mail, email or fax.

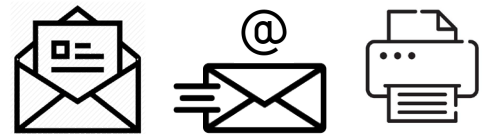

Please complete and return form with **required documentation** of the expense, such as an invoice, advertisement or price quote to:

Wendy French

OTARMA

Customer Service Representative

315 South Kalamazoo Mall

Kalamazoo, MI 49007

wfrench@bfgroup.com

Fax: (269) 276-4095

Phone: (888) 748-7966, ext. 3136



Leading the Way for Ohio Townships

OTARMA.org

A & A Safety, Inc.
1126 Ferris Road
Amelia, OH 45102

Invoice: 195289

(513) 943-6100

Sold
to

West Chester Township
9113 Cincinnati-Dayton Road
West Chester, OH 45069

Ship
to

West Chester Township
9113 Cincinnati-Dayton Road
West Chester, OH 45069

<u>Account</u>	<u>P.O. Num</u>	<u>Ship Via</u>	<u>Ship Date</u>	<u>Terms</u>	<u>Invoice Date</u>	<u>Page</u>
WESTTOWN	20231226	Customer Pick Up	9/15/23	Net 30	9/18/23	1

<u>Item</u>	<u>Quantity</u>	<u>Description</u>	<u>Unit Price</u>	<u>Extended Price</u>
004-1461	50ea	42" Looper Cone, (4) 6" HIP, 16lb Base	34.00ea	1,700.00*
004-1120	50ea	28" 7lb Cone, 6"/4" Collars	21.00ea	1,050.00*

* means item is non-taxable

Subtotal 2,750.00

Total \$2,750.00

AGENDA ITEM COVER SHEET



Trustee Meeting Date:	Agenda Item Type:
November 14, 2023	Business Item
Submitted By:	
Larry D. Burks, Township Administrator	

Motion:
Motion to apply for Ohio Township Association Risk Management Authority (OTARMA) Police and Fire Grant; and, authorize Township Administrator to accept said grant if awarded

Background:
<p>The Police and Fire Grant is designed to assist OTARMA Members with either developing or updating policies and procedures for both police and fire departments. As such, OTARMA Members may apply for up to \$2,000 (\$1,000 for Police and \$1,000 for Fire) in grant funds for contracting with a service provider specializing in police and/or fire policies and procedures, subject to the conditions on the application.</p> <p>The West Chester Police Department has used Lexipol since 2012, and the Fire Department since April 2017. If the grant is awarded, this will be a small but welcomed reduction to the Lexipol subscription cost.</p>

Finance	Budgeted Item:	N/A;		
	CIP #:			
	TIF Info:			
	Purchase Order:		Total Encumbrance:	\$.00



2023 Police & Fire/EMS Grant

New - EMS just added!

This grant assists OTARMA Members with developing or updating policies and procedures, providing training, and purchasing safety equipment for police & fire/EMS departments. Some examples include, but are not limited to, Personal Protective Equipment (PPE), boots, body armor, flashlights, turnout gear, and Self-Contained Breathing Apparatus (SCBA).



The Police & Fire/EMS Grant Program is only available to OTARMA Members with their own Police and/or Fire/EMS Departments. Grant funds up to \$2,000 (\$1,000 for Police and \$1,000 for Fire/EMS) may be applied for per calendar year.

Members with Police and Fire/EMS Departments are encouraged to apply for a grant during the application period January 1 - December 31, 2023. Applications that are incomplete or are not submitted within the required time frame may be deemed ineligible. Each applicant must be an OTARMA Member both at the time of submission and issuance of the grant funds. Approved funds will be issued once membership is verified. The funds are available for purchases or expenses incurred during the application period.

Weapons are excluded.

There is a brief application on the OTARMA Website at www.OTARMA.org or contact Wendy French at (269) 341-4829 or email wfrench@bfgroup.com.

2023 Police & Fire/EMS Grant Application

New - EMS added!

Please complete this form to apply for a Police and Fire/EMS Grant:

Township West Chester Township

County Butler

Contact Jenna Whittaker

Title Executive Assistant

Address 9113 Cincinnati Dayton Road

E-mail jwhittaker@westchesteroh.org

Phone Number 513-777-5900

Amount Requested (up to \$1,000 per department, per calendar year)

Police Department \$ 1000 Fire/EMS Department \$ 1000

What specifically will the funds be used for? (Please provide a brief description and designate Police or Fire/EMS)

Developing or updating policies and procedures Police and fire

departments use Lexipol to train employees on dept. policies and procedures through the online annual subscription.

Lexipol also includes 24/7 access to Knowledge Management System for updates and editing.

Training Personnel Lexipol provides 365 Unique Scenario Daily Training

Bulletins and Testing Database.

Safety Equipment _____

The Police and/or Fire/EMS Department must be part of an **OTARMA** Member's operation (not contracted or outsourced) at the time of submission and issuance of grant funds.

Police & Fire/EMS Grant Applications must be received by December 31, 2023. Submissions are accepted via mail, email or fax.

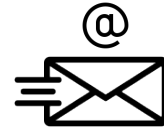

Please complete and return this form with required documentation of the expenses such as an invoice. Once the application is approved, an OTARMA Member will be reimbursed for up to \$1,000 per department, for a possible total of up to \$2,000 per calendar year.

Submit to:

Wendy French

OTARMA

Customer Service Representative

315 South Kalamazoo Mall

Kalamazoo, MI 49007

wfrench@bfgroup.com

Fax: (269) 276-4095

Phone: (888) 748-7966, ext. 3136

Program Details:

The Police & Fire/EMS Grant funds are available for developing or updating policies and procedures for police and fire/EMS departments, training for police and fire/EMS personnel, and purchasing safety equipment for police and fire/EMS departments.



www.OTARMA.org

Leading the Way for Ohio Townships

VENDOR NO. 02698

CHECK DATE 03/01/2023

CK# 166118

INVOICE NO.	INV. DATE	DESCRIPTION	INVOICE AMOUNT	DISCOUNT	NET AMOUNT
INVPRA111977	12/01/22	FIRE RESCUE 1 ACAD	7446.90	0.00	7446.90
SUB010346	12/01/22	LEXIPOL ONLINE ANN	14437.39	0.00	14437.39
LEXIPOL LLC			21884.29	0.00	21884.29



9113 Cincinnati-Dayton Rd.
West Chester, OH 45069

FIRST FINANCIAL BANK
VOID AFTER 90 DAYS

56-91/422

West Chester
— OHIO —

CHECK DATE	CHECK NO.
03/01/2023	166118

AMOUNT
*****21,884.29

031207607

8026454197

TWENTY ONE THOUSAND EIGHT HUNDRED EIGHTY FOUR DOLLARS AND 29 CENTS

DEPOSIT
TO THE
ACCOUNT
OF

LEXIPOL LLC
2611 INTERNET BLVD
SUITE 100
FRISCO, TX 75034

NOT A VALID CHECK

NON-NEGOTIABLE

NON-NEGOTIABLE



POLICE 1) CORRECTIONS 1)
 FIRE RESCUE 1) EMS 1) GOV 1)

Invoice

Date 12/1/2022
 Invoice # INVPR111977
 Terms Net 30
 Due Date 12/31/2022
 PO #

Bill To

West Chester Fire Department
 9119 Cincinnati-Dayton Rd
 West Chester, OH 45069

End User

West Chester Fire Department

Contract Term

1/1/2023 to 12/31/2023

Item	Amount
Fire & EMS Platform/Mobile Solution	6,751.65
Fire Instructor	103.00
EVALS	0.00
Master Class Series	592.25
<p>APPROVED FOR PAYMENT DATE _____</p> <p>P.O. # <u>8230592</u> ACCT. # _____</p> <p>DEPT. HEAD <u>[Signature]</u></p>	

Invoice Total 7,446.90
Amount Due \$7,446.90

Contact Information:
 Phone: 844-312-9500
 Email: receivables@lexipol.com

ACH Payments to:
 Routing# 031207607
 Account# 8026458657
 PNC Bank, N.A.
 249 Fifth Avenue
 Pittsburgh, PA 15222

Please Make Checks Payable to:
 Lexipol
 2611 Internet Blvd, Suite 100
 Frisco, Tx 75034-9085

FIRE DEPT STATION 71
 9119 CINCINNATI DAYTON RD
 WEST CHESTER, OH 45069



West Chester
 - OHIO -

PURCHASE ORDER NO.
 S230542

513-777-1133

PURCHASE ORDER

ISSUE DATE
 02/07/23

VENDOR NO.	ADDRESS NO.	DELIVERY REQUIRED	TERMS	SHIP VIA	F.O.B.	REQUISITION NO.
02698	0	02/08/23				

ISSUED LEXIPOL LLC
 TO 2611 INTERNET BLVD
 SUITE 100
 FRISCO, TX 75034

SHIP TO
 FIRE DEPT STATION 71
 9119 CINCINNATI DAYTON RD
 WEST CHESTER, OH 45069

FAX: 949-484-4443

ACH VENDOR FOR MORE INFORMATION CONTACT: FIRE DEPT STATION 71

TELEPHONE NO.: 513-777-1133

ITEM NO.	QUANTITY	U / M	DESCRIPTION	UNIT PRICE	EXTENDED PRICE
1			LEXIPOL ONLINE SUBSCRIPTION ANNUAL AGREEMENT ACCOUNT DISTRIBUTION: 210-FD00-5483-000-000000	14437.39 14437.39	14437.39
2			FIRE RESCUE 1 ACADEMY ACCOUNT DISTRIBUTION: 210-FD00-5317-000-000000	7446.90 7446.90	7446.90
<p>Then and Now Certification it is hereby certified that both at the time of the making of this contract or order and at the date of the execution of this certification, the amount was appropriated for such contract or order and is in the treasury or in the process of collection to the credit of the proper fund, free from any previous encumbrances</p> <p>Approved: <u>Keck 3-1-23</u></p>					
				SUB-TOTAL	21884.29
				TAX	0.00
				SHIPPING AND HANDLING CHARGE	0.00
THIS ORDER IS EXEMPT FROM SALES AND USE TAX.		AREA : AGENDA ITEMS		TOTAL OF PURCHASE ORDER	
					21884.29

Bruce Jones
 2/14/23

INSTRUCTIONS TO THE VENDOR:

1. Purchase order number must appear on all invoices, packing slips and correspondence.

I hereby certify that the amount required to meet the obligation created by this instrument has been lawfully appropriated for such purpose, is in the treasury or in the process of collection to the credit of the proper fund, free from any previous encumbrance.

BRUCE JONES

PURCHASING AGENT

02/15/23

DATE

Bruce Jones
 AUTHORIZED SIGNATURE



LEXIPOL

2611 Internet Blvd
Ste 100
Frisco TX 75034
United States

Subscription

Invoice #

Id SUB010346

Term Annual

Next Bill 4/1/2023

West Chester Fire Department
West Chester Fire Department
9119 Cincinnati-Dayton Rd
West Chester OH 45069
United States

This is NOT an Invoice

Quantity	Item	Rate	Amount
1	Annual Fire Supplemental Manual(s)_01t1a000001riEMAAY_151-200_renewal Annual Fire Supplemental Manual(s)	2,066.12	\$2,066.12
1	F_MAN_151-200_MAN_renewal Annual Fire Policy Manual & Daily Training Bulletins	10,623.61	\$10,623.61
1	Annual Fire Supplemental Manual(s)_01t1a000001riEMAAY_151-200_renewal Annual Fire Supplemental Manual(s)	1,747.66	\$1,747.66
		Total	\$14,437.39

APPROVED FOR PAYMENT DATE _____

P.O. # S236542 CO. # _____

DEPT. HEAD [Signature] _____



Invoice

#INVLEX120013

11/1/2023

Bill To

West Chester Police Department
9577 Beckett Rd Ste 500
West Chester OH 45069
United States

End User

West Chester Police Department

Terms	Due Date	PO #	Contract Term
Net 30	12/1/2023		12/1/2023 to 11/30/2024

Description	Qty	Rate	Amount
Annual Law Enforcement Policy Manual & Daily Training Bulletins	1	\$17,394.00	\$17,394.00

Your invoice includes a 10 % discount.

Subtotal	\$17,394.00
Tax Total (%)	\$0.00
Invoice Total	\$17,394.00
Amount Paid	\$0.00
Amount Due	\$17,394.00

[Click here to submit your accounting inquiry.](#)

Lexipol now has an easier way for you to view/pay your invoices. Please set up/login to your account today at [LEXIPOL CUSTOMER PORTAL](#) If you have difficulty logging in, please click on the reset password link, reset your password, and attempt logging in again.

Please Make Checks Payable to:
Lexipol, LLC
2611 Internet Blvd, Suite 100
Frisco, Tx 75034-9085

AGENDA ITEM COVER SHEET



Trustee Meeting Date:	Agenda Item Type:
November 14, 2023	Business Item
Submitted By:	
Larry D. Burks, Township Administrator	

Motion:
Motion to re-appoint Larry D. Burks, Township Administrator, and Mr. Bruce Jones, West Chester resident, as the West Chester Township representatives to the Butler County Transportation Improvement District (TID) Board (terms effective January 1, 2024 through December 31, 2025)

Background:
West Chester has two representing votes on the Butler County TID Board: the Township Administrator and a resident at large.
I am requesting the Board’s consideration in re-appointing your current representatives as West Chester’s appointees to the Butler County TID Board for two-year terms, effective January 1, 2024 through December 31, 2025.

Finance	Budgeted Item:	N/A;		
	CIP #:			
	TIF Info:			
	Purchase Order:		Total Encumbrance:	\$.00

AGENDA ITEM COVER SHEET



Trustee Meeting Date:	Agenda Item Type:
November 14, 2023	Business Item
Submitted By:	
Larry D. Burks, Township Administrator	

Motion:
 Motion to approve agreement between West Chester Township Board of Trustees and Butler County, Ohio for continued use of space at West Chester Safety Services Building at a cost of \$3,333.33 per month; and, authorize Township Administrator to make non-substantive changes with Law Director approval and execute said agreement

Background:
 West Chester and Butler County entered into an agreement in 2003 to locate Butler County Area III Court in the West Chester Safety Services Building. In lieu of rent, the County provided an up-front contribution to construction of the space in the amount of \$250,000.00. The location of Area III Court in West Chester has afforded benefits to both parties, and continued collaboration provides cost savings and increased efficiency to the County, the Township, and West Chester residents.

The proposed renewal agreement is for an 18 month period beginning March 1, 2024 and ending August 31, 2025. During this time, Butler County will pay \$3,333.33 per month in rent for a total of \$60,000.00 during the life of the agreement. Per the agreement, the Township is responsible for maintenance and repair of structural and mechanical systems and will pay all fees related to utilities and janitorial services on behalf of the Court.

Administration requests Trustee approval of the 18 month rental agreement with Butler County.

Finance	Budgeted Item:	N/A;		
	CIP #:			
	TIF Info:			
	Purchase Order:		Total Encumbrance:	\$.00

LEASE AGREEMENT

THIS LEASE AGREEMENT ("Agreement") is dated as of _____ 2023, by and between **WEST CHESTER TOWNSHIP, BUTLER COUNTY, OHIO**, a township organized and existing under and by virtue of the laws of the State of Ohio, with its principal office located at 9113 Cincinnati-Dayton Road, West Chester, Ohio 45069 (herein "Lessor") and **BUTLER COUNTY, OHIO**, a county organized under and by virtue of the laws of the State of Ohio, with its principal office located at the Government Services Center 315 High Street, 6th Floor, Hamilton, Ohio 45011 (herein "Lessee").

1. **Demised Premises.**

- 1.1 Lessor owns certain real property located at 9577 Beckett Road, West Chester Township, Ohio 45069 and buildings located thereon which are currently rented to Lessee for use by Butler County Area III Court for court, office and storage use (the "Buildings").
- 1.2 Lessor hereby demises and leases to Lessee, and Lessee hereby leases from Lessor the premises located within the Buildings identified on Exhibit A attached hereto (the "Premises"), subject to the provisions of this Agreement.
- 1.3 The Premises shall be for the exclusive use of Butler County Area III Court but all other common areas shall be for the benefit of invitees of other tenants located within the Buildings; provided, however, Lessee may use the common areas at the entryway.

2. **Term of Lease.** Lessee will have and hold the Premises upon possession, commencing March 1, 2024 ("Effective Date"), and shall continue for eighteen (18) months, through August 31, 2025 unless sooner terminated as provided hereunder (the "Term").

3. **Base Rent.** Lessee covenants to pay to Lessor at its notice address, or at such place or to such person as Lessor may designate in writing from time to time, rent for the Premises in the amount of \$3,333.33 per month due on the 15th of each month for the previous month's rent commencing upon effective date of this Agreement.

4. **Use of Premises.** Lessee will use the Premises solely for Butler County Area III Courts, office and storage space and will not use, or permit any person to use, the Premises for any use or purpose in violation of any applicable: (i) governmental law, rule or regulation (collectively, "Laws"); or (ii) easement, restriction, agreement or declaration of record as of the date hereof.

5. **Maintenance and Charges.** Lessor shall: (i) maintain the exterior portions of Premises, including but not limited to the Buildings, all improvements thereto, all Building fixtures, all of the mechanical, electrical, plumbing, heating, ventilating and air conditioning and other building systems (collectively, the "Systems"), the roof and structural components, and will keep the same in good working order and condition; (ii) make all necessary repairs to the exterior, structural or nonstructural, and to all parts of the same including the driveway, the parking area, and to provide for snow plowing of the same; and (iii) pay when due all charges for fuel, water, gas, electricity, power, refrigeration, and other utilities and services, trash removal and janitorial services. Lessee shall cause the Premises at all times, at its sole cost and expense, to remain in good condition, reasonable wear and tear excepted.

6. **Construction and Alteration.** All material improvements and alterations to the Premises in excess of \$5,000.00 will require the prior written consent of Lessor, and Lessee will submit plans and specifications for each intended improvement or alteration to Lessor for review and approval before commencing construction. Title to any approved improvements or alterations made by Lessee will vest in Lessor at the end of the Term, and Lessee will deliver such documents of conveyance thereof as Lessor may reasonably request (including without limitation assignments of any outstanding warranties), and Lessor agrees to accept the Premises with any approved improvements and alterations. Lessee may place such trade fixtures,

- personal property, machinery, furniture, equipment and the like on the Premises as it may desire at its own expense.
7. **Insurance.** Lessee shall obtain and keep in full force at the sole cost and expense of Lessee policies of insurance to insure against claims for injuries to persons or damages to property which may arise from or in connection with the Lessee's operation and use of the Premises. Lessee shall provide evidence of the same upon request of Landlord.
 8. **Fire or Other Casualty.** If during the Term of this Agreement any Premises is damaged by fire or other casualty as to be rendered: (a) untenable in whole or in substantial part, (b) destroyed in whole or in substantial part or (c) the insurance proceeds are insufficient to repair the damage to the Building, then either Lessee or Lessor may terminate this Agreement effective the date of such casualty with respect to that Premises but this Agreement shall continue with respect to the others. Lessee's or Lessor's election shall be made within thirty (30) days after the determination of (a), (b) and (c) above, otherwise each parties right to termination shall be deemed waived. If this Agreement is not terminated, either because the damage does not render Premises untenable, either in whole or substantial part or because neither Lessee or Lessor elects to terminate this Agreement pursuant to the preceding provisions, then Lessor shall with all due diligence, repair and restore the Premises to substantially their original condition (excepting alterations or improvements made by Lessee, if so desired by Lessor) by not later than one-hundred-twenty (120) days after the occurrence of the casualty.
 9. **Covenants and Representations.** During the Term, Lessee shall not without Lessor's written consent, part with possession or control of the Premises, or sublease, sell, assign, pledge, mortgage or otherwise encumber the Premises or any part thereof. Lessor shall be entitled to inspect the Premises and all records of Lessee pertaining thereto upon request and during normal business hours.
 10. **Default.** Each of the following events shall constitute an "Event of Default" hereunder:
 - 10.1 Lessee fails to make payment of any rent or other sum due to Lessor as and when required;
 - 10.2 Lessee fails to procure or maintain insurance on the Premises required herein; or
 - 10.3 Lessee fails in the performance or observance of any of the other covenants, conditions or agreements to be performed or observed by it under this Agreement and such failure shall continue uncured for seven (7) days after written notice thereof to Lessee by Lessor.
 11. **Remedies.** Upon the happening of an Event of Default, Lessor may at its option undertake one or more of the following actions:
 - 11.1 proceed by appropriate court action or actions to enforce performance by Lessee of the applicable covenants and provisions of this Agreement or to recover damages for the breach thereof;
 - 11.2 terminate this Agreement, without prejudice to Lessor's rights in respect to obligations then accrued and remaining unsatisfied as well as the remedies and claims referred to herein;
 - 11.3 re-enter and take complete and peaceful possession of the Premises, with or without process of law, and may remove all persons therefrom, and Lessee covenants in any such event to peacefully and quietly to yield up and surrender the Premises to Lessor;
 - 11.4 avail itself of any other remedy or remedies provided for by any statute or otherwise available at law, in equity or in bankruptcy or insolvency proceedings;

12. **Quiet Possession.** Lessee, upon paying the specified rental and performing the other covenants herein agreed by it to be performed, will peacefully and quietly have, hold and enjoy the Premises for the Term without any let, hindrance, or molestation by Lessor or any persons lawfully claiming under Lessor, subject only to the other provisions of this Agreement.
13. **Condition of Premises upon Surrender.** At the expiration of the Term, Lessee will quit and surrender the Premises in good condition, reasonable wear and tear accepted, and remove all of its personal property and trade fixtures. In the event Lessee builds upon, alters, adds to or improves the Premises in accordance with its rights hereinbefore granted, it will not, at the expiration of said Term, be required to restore the same, but Lessee will surrender the same in its improved or altered condition without any further liability.
14. **Waiver of Jury Trial.** Lessee hereby knowingly, voluntarily and intelligently waives its constitutional right to a trial by jury with respect to any claim, dispute, conflict, or contention, if any, as may arise under this Agreement or under any documents executed in connection herewith and agrees that any litigation between the parties concerning this Agreement and the related documents shall be heard by a court of competent jurisdiction sitting without a jury.
15. **Notices.** All notices, requests and other communications hereunder will be in writing and will be sent by: (a) personal delivery; (b) overnight courier service that regularly maintains a record of its deliveries, charges prepaid; or (c) certified U.S. mail, postage prepaid, return receipt requested, and addressed to the parties as set forth above.
Execution. This Agreement will not be binding and effective until a counterpart hereof has been executed and delivered by the parties each to the other. This Agreement may not be modified except by an instrument in writing.
16. **Access to Premises.** Lessor and its agents will have the right to enter the Premises after 24 hours' notice to Lessee to examine the condition of same or to show the Premises to prospective purchasers or mortgagees.
17. **Waiver.** No waiver of any of the covenants and agreements herein contained or of any breach thereof will be taken to constitute a waiver of any other subsequent breach of such covenants and agreements or to justify or authorize the non-observance at any other time of the same or of any other covenants and agreements hereof.
18. **Parties Consent.** Where consent is required of each party in this Agreement, Lessor and Lessee shall not unreasonably withhold, delay or condition such consent.
19. **Severability.** If any clause or provision of this Agreement is illegal, invalid or unenforceable, then and in that event, it is the intention of the parties hereto that the remainder of this Agreement will not be affected thereby, and it is also the intention of the parties to this Agreement that in lieu of each clause or provision of this Agreement that is illegal, invalid or unenforceable, there be added as a part of this Agreement a clause or provision as similar in terms to such illegal, invalid or unenforceable clause or provision as may be possible and be legal, valid and enforceable.
20. **Entire Agreement.** This Agreement constitutes the entire understanding between the parties and supersedes all prior agreements. No waiver, modifications, or additions to this Agreement will be valid unless in writing and signed by both the Lessor and the Lessee.
21. **Governing Law.** This Agreement shall be construed in accordance with and governed by the laws of the State of Ohio.
- 22.

LESSOR:

West Chester Township, Butler County, Ohio

By: _____

Name: _____

Its: _____

LESSEE:

Butler County, Ohio

By: _____

Name: _____

Its: _____

STATE OF OHIO

)SS:

COUNTY OF BUTLER)

The forgoing instrument was acknowledged before me this _____ day of _____, 2023, by _____, _____ of WEST CHESTER TOWNSHIP, OHIO, a township organization and existing under and by virtue if laws of the state of Ohio, on behalf of the township.

Notary Public

Approve as to form only:

Dan L. Ferguson
Assistant Prosecuting Attorney

Date

EXHIBIT A
PREMISES

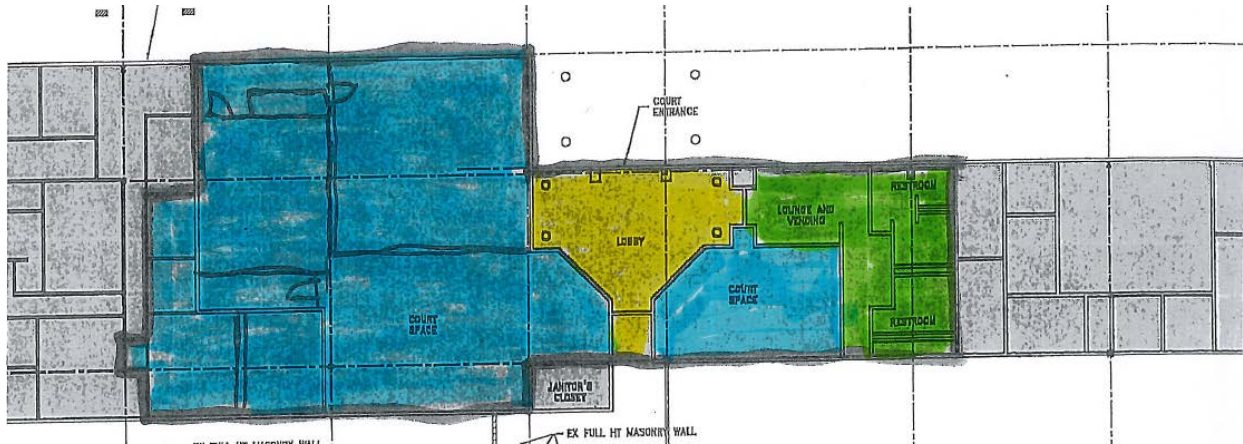

- Area highlighted in “blue” reflects the “Premises”
- Area highlighted in yellow and green reflect “common areas”

AGENDA ITEM COVER SHEET



Trustee Meeting Date:	Agenda Item Type:
November 14, 2023	Business Item
Submitted By:	
Kenneth Keim, Director of Finance	

Motion:
Motion to approve Resolution 44-2023 amending the Township 2023 Permanent Appropriations

Background:
<p>Amendments to permanent appropriations are proposed and presented periodically throughout the year for the Board’s approval and this is because revenues are forecasted and expenditures are estimated months in advance for most steps in the budgetary cycle; therefore, adjustments are necessary. The adjustments ensure the Township’s budget projections for revenues and estimates for expenditures accurately reflect what occurs throughout the year.</p> <p>The following Resolutions were presented and approved throughout the 2023 budget cycle: Resolution 21-2022 establishing the 2023 tax budget; Resolution 42-2022 approving the 2023 Temporary Appropriations; Resolution 14-2023 approving the 2023 Permanent Appropriations and Resolution 40-2023 amending the 2023 Permanent Appropriations. Additionally, a public work session for the 2023 Operational Budget for the primary funds for Township services was conducted on February 14, 2023.</p> <p>The subject resolution amends the appropriations in various funds to account for necessary adjustments effectuated by conditions and circumstances difficult to anticipate so far in advance. Although each fund is unique, the proposed amended appropriations reflect circumstances actualized throughout the multiple steps of the 2023 budget cycle and are summarized below:</p> <p>Fund 216 – Tylersville TIF: PILOT payments were higher than originally estimated and we need to increase so we can pay our obligations to Lakota and Butler County TID.</p> <p>Fund 218 - UCB TIF: PILOT payment(s) were originally receipted into the UCB TIF fund however the need to pay debt service payments exceed what is currently available in those funds so we are instead diverting those PILOT receipt(s) to Fund 318.</p> <p>Fund 318 - UCB Debt Service: PILOT payment(s) were originally receipted into the UCB TIF fund however the need to pay debt service payments exceed what is currently available in those funds so we are instead diverting those PILOT receipt(s) to Fund 318.</p> <p>Fund 319 – 747 Debt Service: PILOT payments received in this fund were slightly less than originally planned.</p> <p>Please let me know if you have any questions; thank you for your consideration.</p>

Finance	Budgeted Item:	N/A;		
	CIP #:			
	TIF Info:			
	Purchase Order:		Total Encumbrance:	\$.00

RESOLUTION NO. 44-2023

Statutory Resolution amending the Township 2023 Permanent Appropriations

WHEREAS, West Chester Township has received the final property tax settlement for 2023 budget year; and,

WHEREAS, the Board of Trustees finds it necessary to amend the Township 2023 Appropriations; and,

WHEREAS, the Butler County Budget Commission must allow the Township Fiscal Officer to appropriate the necessary amounts for all Township funds; and,

NOW THEREFORE, BE IT RESOLVED, the West Chester Township Board of Trustees hereby agrees to:

SECTION 1. Authorize the Township Fiscal Officer to amend the 2023 Appropriations as illustrated.

PROPOSED

Fund #	Fund Name	Department	Resolution 14-2023 2023 Appropriations			Net Change			Amended Resolution 44-2023		
			Salaries and Benefits	Other	Total	Salaries and Benefits	Other	Total	Salaries and Benefits	Other	Total
101	General		-	-	-						
		Admin	2,034,979	3,330,269	5,365,248			-	2,034,979.00	3,330,269.00	5,365,248.00
		Comm. Dev	867,472	309,882	1,177,354			-	867,472.00	309,882.00	1,177,354.00
		Parks	375,554	520,690	896,244			-	375,554.00	520,690.00	896,244.00
		Services	704,952	79,600	784,552			-	704,952.00	79,600.00	784,552.00
		Other	-	31,500	31,500			-	-	31,500.00	31,500.00
	Total		3,982,957.00	4,271,941.00	8,254,898.00				3,982,957.00	4,271,941.00	8,254,898.00
201	Township Motor Vehicle Tax		-	642,816	642,816			-	-	642,816.00	642,816.00
202	Motor Vehicle License Tax		-	141,000	141,000			-	-	141,000.00	141,000.00
203	Gasoline Tax		-	1,107,100	1,107,100			-	-	1,107,100.00	1,107,100.00
204	Road & Bridge		1,957,271	2,075,000	4,032,271			-	1,957,271.00	2,075,000.00	4,032,271.00
205	Cemetery		296,239	74,450	370,689			-	296,239.00	74,450.00	370,689.00
207	Multi-Media & Marketing		533,210	756,856	1,290,066			-	533,210.00	756,856.00	1,290,066.00
209	Police Levy		16,311,628	2,952,723	19,264,351			-	16,311,628.00	2,952,723.00	19,264,351.00
210	Fire Levy		15,646,145	2,731,103	18,377,248			-	15,646,145.00	2,731,103.00	18,377,248.00
211	EMS		1,093,272	799,743	1,893,015			-	1,093,272.00	799,743.00	1,893,015.00
212	Capstone Blvd TIF Service		-	-	-			-	-	-	-
213	Cinti-Columbus TIF Service Payments		-	234,749	234,749			-	-	234,749.00	234,749.00
214	Tylers Place TIF Service Payments		-	511,274	511,274			-	-	511,274.00	511,274.00
215	Cin-Day TIF Service Payments		-	1,908,226	1,908,226			-	-	1,908,226.00	1,908,226.00
216	Tylersville TIF Service Payments		-	116,401	116,401		52,595.82	52,595.82	-	168,996.75	168,996.75
217	CBD TIF Service Payments		-	9,703,849	9,703,849			-	-	9,703,849.00	9,703,849.00
218	UCB TIF Service Payments		-	47,569,412	47,569,412		(2,368,794.00)	(2,368,794.00)	-	45,200,618.00	45,200,618.00
219	747 TIF Service Payments		-	28,206,626	28,206,626			-	-	28,206,626.00	28,206,626.00
221	Enforcement & Education		-	30,300	30,300			-	-	30,300.00	30,300.00
224	West Chester Connections		-	177,011	177,011			-	-	177,011.00	177,011.00
225	Police Assistance Fund		-	60,895	60,895			-	-	60,895.00	60,895.00
226	Sustainable Infrastructure		-	11,952,003	11,952,003			-	-	11,952,003.00	11,952,003.00
262	Drug Law Enforcement		-	414,557	414,557			-	-	414,557.00	414,557.00
270	Asset Forfeiture		-	627,975	627,975			-	-	627,975.00	627,975.00
274	OneOhio Opioid Settlement		-	53,242	53,242.00			-	-	53,242.00	53,242.00
275	Coronavirus Relief Fund		-	4,973,956	4,973,956.00			-	-	4,973,956.00	4,973,956.00
317	CBD TIF Debt Service		-	-	-			-	-	-	-
318	UCB TIF Debt Service		-	1,804,943	1,804,943.00		2,368,794.00	2,368,794.00	-	4,173,737.00	4,173,737.00
319	747 TIF Debt Service		-	219,844	219,844.00		(8,553.73)	(8,553.73)	-	211,290.27	211,290.27
333	Capstone Debt Service		-	228,800	228,800.00			-	-	228,800.00	228,800.00
507	Lighting District Assessments		-	844,420	844,420.07			-	-	844,420.07	844,420.07
508	UCB Landscape District		152,286	520,535	672,821.00			-	152,286.00	520,535.00	672,821.00
606	Cemetery Bequest			16,683	16,683.00			-	-	16,683.00	16,683.00
	Total		39,973,008.00	125,728,433.00	165,701,441.00		-	44,042.09	44,042.09	39,973,008.00	125,772,475.09

Adopted this 14th day of
November, 2023.

Ann Becker, Chair Yes/No

Lee Wong, Vice Chair Yes/No

ATTEST:

Mark S. Welch, Trustee Yes/No

Bruce Jones, Fiscal Officer

APPROVED AS TO FORM:

Donald L. Crain, Law Director

PROPOSED

AGENDA ITEM COVER SHEET



Trustee Meeting Date:	Agenda Item Type:
November 14, 2023	Business Item
Submitted By:	
Aaron Wiegand, Director of Community Development	

Motion:
Motion to approve Resolution 45-2023 Authorizing the Acceptance of the Proposed Settlement Agreement Resolving West Chester Township’s Zoning Enforcement Case Against the Property Located at 8295 Grinn Drive, West Chester, Ohio 45069

Background:
<p>West Chester Township Community Development has had numerous zoning and property maintenance violations at 8295 Grinn Drive for over a year regarding the outdoor storage of miscellaneous junk and the storage of junk vehicles on-site. The property has recently sold to new owners and the sellers wish to settle the Township’s case against the property.</p> <p>This judgment entry provides all of the relief the Township was seeking. This Court Order requires the property owner to be keep in good standing or be subject to Contempt of Court charges in the future. In anticipation of sale, the property has been cleaned by the owner and is currently in good standing. The settlement also includes a \$10,000 payment from the Stamey Trust to West Chester Township to account for various legal fees and staff time in dealing with this case.</p> <p>This judgment entry continues the Township’s goals of using all means necessary to ensure compliance with our zoning and property maintenance codes and protects neighboring properties from further disregard of these policies.</p>

Finance	Budgeted Item:	N/A;		
	CIP #:			
	TIF Info:			
	Purchase Order:		Total Encumbrance:	\$.00

RESOLUTION NO. 45-2023

**Resolution Authorizing the Acceptance of the Proposed Settlement Agreement
Resolving West Chester Township’s Zoning Enforcement Case Against the Property Located
at 8295 Grinn Drive, West Chester, Ohio 45069**

WHEREAS, Ohio Revised Code 519.24 empowers the Board of Trustees of West Chester Township (the “Township”) to prevent, prosecute, and abate zoning resolution violations within the Township;

WHEREAS, the property located at 8295 Grinn Drive, West Chester, Ohio, 45069 (the “Property”) has been the subject of multiple resident complaints over the past few years due to the accumulation of junk and debris on the exterior of the property and the condition of the structure.

WHEREAS, the Property has been in violation of the Township’s Exterior Zoning Resolution and Township’s Exterior Property Maintenance Code;

WHEREAS, the Township filed suit to abate the violations and nuisance conditions at the Property in Butler County Court of Common Pleas case number CV 2023 05 0955 (the “Nuisance Case”);

WHEREAS, since filing the Nuisance Case work has been done to clean up the exterior of the Property;

WHEREAS, the Board of Trustees has determined that it is in the best interests of the public health, safety and welfare to enter into the Settlement Agreement and Mutual Release, attached as Exhibit A, as a resolution to the Nuisance Case;

NOW THEREFORE, BE IT RESOLVED that on the basis of the above actions and findings, the West Chester Township Board of Trustees:

SECTION 1. That the Board of Trustees does hereby authorize Township Administrator Larry Burks, or his designee, to sign the Settlement Agreement and Mutual Release in substantially similar form as the attached Exhibit A, on behalf of the Township, and to sign any other documents necessary to effectuate the settlement.

Adopted this _____ day of _____, 2023.

Ann Becker, Chair

Yes/No

ATTEST:

Lee Wong, Vice Chair

Yes/No

Bruce Jones, Fiscal
Officer

Mark Welch, Trustee

Yes/No

APPROVED AS TO FORM:

Donald L. Crain, Law Director

DRAFT

SETTLEMENT AGREEMENT AND MUTUAL RELEASE

This Settlement Agreement and Mutual Release (“Agreement”) is by and between the Board of Trustees of West Chester Township, Butler County, Ohio (the “Township”), the Sara Stamey Living Trust dated December 27, 2012, (“Owner”), and DHT Properties LLC (“Buyer”). The Township, Owner, and Buyer are hereinafter collectively referred to as the “Parties” and individually as a “Party.” This Agreement shall be effective as of the date upon which the last Party to execute this Agreement has done so, as evidenced by the dates set forth on the signature page of this Agreement (the “Effective Date”), and is premised upon the following recitals:

RECITALS

WHEREAS, on or about October 8, 2021, the Township filed a Complaint against Sarah Stamey, her unknown heirs, and other various defendants for Declaratory and Injunctive Relief relating to a nuisance property and civil fines in Butler County Court of Common Pleas Case Number CV 2023 05 0955 (the “Suit”);

WHEREAS, Sarah Stamey is the listed owner of the property located at 8295 Grinn Drive, West Chester Township, Butler County, Ohio 45069, Butler County Auditor Parcel ID: M5620153000031 (the “Property”);

WHEREAS, Sarah Stamey passed away in December 2022;

WHEREAS, the Parties desire to resolve and to fully and finally settle all remaining matters in controversy in the Suit;

NOW, THEREFORE, in consideration of the foregoing and of the mutual promises and agreements set forth herein, the receipt and sufficiency of which is acknowledged by the Parties, the Parties agree as follows:

1. Settlement Payment. Within fourteen (14) days of the Effective Date, Owner shall pay ten thousand dollars (\$10,000.00) (the “Settlement Payment”) to the Township in complete settlement of any claim the Township has asserted, or may assert, for unpaid civil fines, attorney’s fees, or court costs arising from the Suit. Defendant shall deliver cash or a check payable to West Chester Township for the Settlement Payment to counsel for the Township at the following address: Attn: Jonathan E. Roach, 9277 Centre Pointe Drive, Suite 300, West Chester, Ohio 45069.

2. Sale of the Property. Within fourteen (14) days of the Effective Date, or at any time beforehand, Owner shall ensure that the Property is sold to Buyer.

3. Repair of Property. Buyer shall bring the Property into compliance with the Township’s Exterior Property Maintenance Code and Zoning Resolution by February 1, 2024. Buyer shall make the Property habitable by May 1, 2024. Buyer shall not transfer the Property to another entity before competing such work and repairs to the Property. Buyer shall make the Property available for inspection by the Township upon reasonable request.

4. **Dismissal of the Suit.** Within fourteen (14) days of receipt of the Settlement Payment, the Township shall dismiss the Suit with prejudice. The dismissal shall indicate that the court retains jurisdiction to enforce the terms of this Agreement.

5. **General Mutual Release.** For valuable consideration received and in consideration of the mutual promises and agreements of the Parties contained herein, the Parties, on behalf of themselves and any and all of their respective owners, heirs, assigns, employees, officers, directors, agents, representatives, predecessors, successors, parent companies, shareholders, members, managers, attorneys, accountants and insurers, predecessors in interest, and anyone claiming by, through or under them, do hereby release and forever hold harmless each other, jointly and/or severally, their respective owners, heirs, employees, agents, representatives, predecessors, successors, parent companies, shareholders, members, managers, officers, directors, subsidiaries, predecessors in interest, successors in interest, assigns, attorneys, accountants and insurers and anyone claiming by, through or under them, from any and all debts, claims, demands, damages, obligations, costs, losses, liabilities, rights, disputes, actions, causes of action, expenses, contracts, judgments, awards and suits of any kind whatsoever, now known or which reasonably could have been known, fixed and contingent, liquidated and unliquidated, whether based on contract, tort, statute or other legal or equitable theory of recovery, arising from any acts or omissions related to the Suit from the beginning of time up to the Effective Date of this Agreement, provided, however, that nothing contained herein shall release, discharge, modify, or impair in any manner whatsoever the respective rights and obligations of the Parties set forth in this Agreement, or the obligations of the Parties to comply with Ohio or Township laws, codes, or resolutions in the future.

6. **Further Assurances.** The Parties agree that this Agreement can either be enforced through a motion filed in the Suit and that the Butler County Court of Common Pleas retains jurisdiction to enforce the terms of this Agreement, or that this Agreement can be enforced through a separate action.

7. **Binding Effect.** The Parties hereto agree that the terms of this Agreement should not be interpreted presumptively to be more or less favorable for or against any signatory. Subject to the terms and conditions hereof, this Agreement shall be binding upon and inure to the benefit of the Parties hereto and their respective heirs, executors, administrators, predecessors in interest, successors and assigns.

8. **Governing Law.** This Agreement in all respects shall be interpreted, governed, and enforced by and under the laws of the State of Ohio.

9. **Forum to Enforce.** In the event that any Party breaches this Agreement, any action to enforce this Agreement shall be filed in the Butler County Court of Common Pleas.

10. **Entire Agreement.** This Agreement constitutes the entire agreement between the Parties with respect to the subject matter hereof and all prior discussions, negotiations, commitments and understandings relating to this subject matter are superseded and merged herein. The terms and provisions of this Agreement shall not be changed, amended, waived, modified or terminated in any respect whatsoever except by written instrument executed by all Parties hereto.

11. No Admission. The Parties agree that the settlement provided for herein is not and shall not be construed to be evidence of, or any admission of, liability or wrongdoing by any of the Parties. The Parties have entered into this Agreement in an effort to compromise disputed claims and to resolve pending litigation and all pending matters between them.

12. Counterparts and Signatures. This Agreement may be executed in one or more counterparts, each of which shall constitute a separate original agreement and all of which, taken together, shall constitute one agreement, binding all Parties hereto, notwithstanding the fact that not all Parties have signed the same counterpart. The exchange of copies of this Agreement and of signature pages by facsimile or electronic transmission shall constitute effective execution and delivery of this Agreement as to the Parties and may be used in lieu of the original Agreement for all purposes. Signatures of the parties transmitted by facsimile or electronically shall be deemed to be their original signatures for all purposes.

13. Severability. If any portion of this Agreement shall be deemed or declared to be unenforceable, invalid, or void, the same shall not impair any of the other portions of this Agreement.

14. Recitals. The Recitals stated within this Agreement are deemed to be a material part of the Agreement.

15. Headings. The descriptive headings of this Agreement are inserted for convenience only and will not control or affect the meaning or construction of any of the provisions hereof.

16. Additional Representations. Each Party hereto further warrants, represents, and acknowledges to the others that:

- (a) each has read and fully understands the terms of this Agreement and agrees to be legally bound by it;
- (b) each has executed the Agreement with full knowledge of any and all rights which it may have;
- (c) each has full and complete authority to make the settlement provided herein, to receive the consideration given for this Agreement, and to execute this Agreement;
- (d) each has neither sold, assigned, transferred, conveyed nor otherwise disposed of any of the claims covered by this Agreement;
- (e) each has a present intent to perform the obligations of the Agreement, fully recognizing that the other Party is specifically relying upon that intent in entering into the Agreement;

- (f) the consideration received by each Party for this Agreement is sufficient, adequate, and constitutes lawful consideration supporting the execution of the Agreement; and
- (g) each has entered into this Agreement based solely and exclusively upon his/her own analysis and his/her counsel's analysis of the facts and information of which each Party and each Party's counsel is independently aware and not based upon or in reliance upon any statements or representations of the other Party (except to the extent such statements or representations are fully and expressly set forth herein).

IN WITNESS WHEREOF, the undersigned have caused this Agreement to be executed and made effective as of the Effective Date.

WEST CHESTER TOWNSHIP

The Sara Stamey Living Trust dated December 27, 2012

Name: _____

Name: Karen A. Rolecik

Title: _____

Title: Trustee

Dated: November ____, 2023

Dated: November ____, 2023

DHT PROPERTIES LLC

Name: DHT Properties LLC, by
Darin Bowling

Title: Member

Dated: November ____, 2023

Approved as to form:

Scott D. Phillips, Assistant Law Director

0091532.0315629 4860-7078-7213

0091532.0315629 4860-7078-7213v3

AGENDA ITEM COVER SHEET



Trustee Meeting Date:	Agenda Item Type:
November 14, 2023	Business Item
Submitted By:	
Colonel Joel M. Herzog, Chief of Police	

Motion:
Motion not to object to a TRFO C1, C2, D6 liquor permit from IYS Ventures LLC dba I Mart Stores, 9171 Union Center Boulevard to Leanne Investment LLC dba I Mart Stores, 9171 Union Center Boulevard

Background:

Finance	Budgeted Item:	N/A;		
	CIP #:			
	TIF Info:			
	Purchase Order:		Total Encumbrance:	\$.00

NOTICE TO LEGISLATIVE
AUTHORITY

OHIO DIVISION OF LIQUOR CONTROL
6606 TUSSING ROAD, P.O. BOX 4005
REYNOLDSBURG, OHIO 43068-9005
(614)844-2360 FAX(614)644-3186

TO

50778250010		TRFO	LEANNE INVESTMENT LLC	
PERMIT NUMBER		TYPE	DBA I MART STORES	
06	01	2023	9171 UNION CENTER BLVD	
ISSUE DATE		WEST CHESTER TWP		
08	25	2023	WEST CHESTER OHIO 45069	
FILING DATE				
C1	C2	D6		
PERMIT CLASSES				
09	948	A	F30049	
TAX DISTRICT			RECEIPT NO.	

FROM 09/13/2023

41545920050			IYS VENTURES LLC	
PERMIT NUMBER		TYPE	DBA I MART STORES	
06	01	2023	9171 UNION CENTER BLVD	
ISSUE DATE		WEST CHESTER TWP		
08	25	2023	WEST CHESTER OHIO 45069	
FILING DATE				
C1	C2	D6		
PERMIT CLASSES				
09	948			
TAX DISTRICT			RECEIPT NO.	



MAILED 09/13/2023

RESPONSES MUST BE POSTMARKED NO LATER THAN. 10/16/2023

IMPORTANT NOTICE

PLEASE COMPLETE AND RETURN THIS FORM TO THE DIVISION OF LIQUOR CONTROL
WHETHER OR NOT THERE IS A REQUEST FOR A HEARING.

REFER TO THIS NUMBER IN ALL INQUIRIES A TRFO 5077825-0010

(TRANSACTION & NUMBER)

(MUST MARK ONE OF THE FOLLOWING)

WE REQUEST A HEARING ON THE ADVISABILITY OF ISSUING THE PERMIT AND REQUEST THAT
THE HEARING BE HELD IN OUR COUNTY SEAT. IN COLUMBUS.

WE DO NOT REQUEST A HEARING.

DID YOU MARK A BOX? IF NOT, THIS WILL BE CONSIDERED A LATE RESPONSE.

PLEASE SIGN BELOW AND MARK THE APPROPRIATE BOX INDICATING YOUR TITLE:

(Signature)

(Title) - Clerk of County Commissioner

(Date)

Clerk of City Council

Township Fiscal Officer

WEST CHESTER TOWNSHIP TRUSTEE
ATTN TOWNSHIP FISCAL OFFICER
9113 CINCINNATI DAYTON RD
WEST CHESTER OHIO 45069



**WEST CHESTER POLICE DEPARTMENT
LIQUOR PERMIT INVESTIGATION**

10/31

Date application received: <u>08/25/23</u>		Report date: <u>10/4/23</u>	
<u>50778250010</u> Liquor Permit Number		<u>TRFO</u> Type of Permit Requested	
Applicant 1: <u>Munadel Rizek</u> Name <u>8950 West 103rd St.</u> Address <u>Palos Hills, IL. 60465</u> City, State, Zip Code		Local law enforcement history: No local history.	
Applicant 1: _____ Name _____ Address _____ City, State, Zip Code		Local law enforcement history:	
Applicant 1: _____ Name _____ Address _____ City, State, Zip Code		Local law enforcement history:	
Applicant 1: _____ Name _____ Address _____ City, State, Zip Code		Local law enforcement history:	

Description of projected location: **I-Mart, 9171 Union Centre Blvd, is located on the southwest corner of Union Centre Blvd and Allen Rd. The business has operated as a BP gas station for many years. The location has entrances off Union Centre Blvd, Allen Rd and Union Centre Dr. The infrastructure is established and adequate to maintain business traffic.**

Diagram/Map attached: Yes

Description of projected business operation: **I-Mart will operate as a convenient style store and gas station. It will maintain its affiliation with BP.**

Public institutions within 500 feet of projected site (May object to permit issue) ex. Schools, Churches, Libraries, Public Playgrounds and Township Parks Additional Institutions should be listed in the investigator's narrative.	
1. None	
Name of Institution	Distance
2.	
Name of Institution	Distance
3.	
Name of Institution	Distance

Impact on surrounding business: **No impact on surrounding area projected.**

Investigator's narrative: **On October 4 2023 I began reviewing the liquor permit application. It was apparent that the names, descriptors and identification numbers closely resembled each other between the previous applicant/permit holder and the new applicant. This caused me to become suspicious. I first researched open source documents and could not determine that the person(s) or LLC's were not the same or same entity. I requested and reviewed Illinois driver license data and other law enforcement data bases to finally determine that the two individuals are in fact different people.**

I attempted to contact Mr. Rizek via the telephone number on the application. There was no answer and no option to leave a message.

I stopped by the store to speak to Mr. Rizek. He was not there but I was able to speak with the manager. He was polite and forthcoming with his information. He stated that Mr. Rizek is leasing the property and it is under contract. He told me that his business will operate as a gas station/convenient style store. This will include the sale of beer, wine and spirituous liquor up to 21% alcohol. He was not sure of the maximum occupancy of the building but told me the square footage was 25000 sq. ft. The business employs four people none of which are underage. The store and gas station will be open 24 hours/7 days a week. The manager does not anticipate any impact on the surrounding area or any problems from the store. Mr. Rizek does operate similar businesses, two in downtown Cincinnati. Both of which have liquor permits. He did not mention operating businesses in his home state of Illinois.

There are no concerns that the approval of this permit will have an adverse effect on public safety efforts. I see no reason to object to this application for this C1 (Beer only in original sealed containers for carry out only), C2 (Wine and mixed beverages in sealed container for carryout only) and D6 (Sale of intoxicating liquor on Sunday between the hours 10:00am or 11:00am and midnight) liquor permit.

Objecting to Liquor Permit? No If yes, please explain reason for objection:

Investigator Name/ ID#

§ 4303.292. Grounds for refusal to issue, transfer or renew permit

(A) The division of liquor control may refuse to issue, transfer the ownership of, or renew, and shall refuse to transfer the location of any retail permit issued under this chapter if it finds:

(1) That the applicant, any partner, member, officer, director, or manager thereof, or any shareholder owning ten per cent or more of its capital stock:

(a) Has been convicted at any time of a crime which relates to fitness to operate a liquor establishment;

(b) Has operated liquor permit businesses in a manner that demonstrates a disregard for the laws, regulations, or local ordinances of this state or any other state;

(c) Has misrepresented a material fact in applying to the division for a permit;

(d) Is in the habit of using alcoholic beverages or dangerous drugs to excess, or is addicted to the use of narcotics.

(2) That the place for which the permit is sought:

(a) Does not conform to the building, safety, or health requirements of the governing body of the county or municipality in which the place is located. As used in division (A)(2)(a) of this section, "building, safety, or health requirements" does not include local zoning ordinances. The validity of local zoning regulations shall not be affected by this section.

(b) Is so constructed or arranged that law enforcement officers and duly authorized agents of the division are prevented from reasonable access to rooms within which beer or intoxicating liquor is to be sold or consumed.

(c) Is so located with respect to the neighborhood that substantial interference with public decency, sobriety, peace, or good order would result from the issuance, renewal, transfer of location, or transfer of ownership of the permit and operation thereunder by the applicant.

(d) Has been declared a nuisance pursuant to Chapter 3767. of the Revised Code since the time of the most recent issuance, renewal, or transfer of ownership or location of the liquor permit.

(B) The division of liquor control may refuse to issue or transfer the ownership of, and shall refuse to transfer the location of any retail permit issued under this chapter if it finds:

(1) That the place for which the permit is sought is so situated with respect to any school, church, library, public playground, or hospital that the operation of the liquor establishment will substantially and adversely affect or interfere with the normal, orderly conduct of the affairs of those facilities or institutions.

(2) That the number of permits already existent in the neighborhood is such that the issuance or transfer of location of a permit would be detrimental to and substantially interfere with the morals, safety, or welfare of the public, and, in reaching a conclusion in this respect, the division shall consider, in light of the purposes of Chapters 4301., 4303., and 4399. of the Revised Code, the character and population of the neighborhood, the number and location of similar permits in

the neighborhood, the number and location of all other permits in the neighborhood, and the effect the issuance or transfer of location of a permit would have on the neighborhood.

(C) The division of liquor control shall not transfer the location or transfer the ownership and location of a permit under division (B)(3)(b) of section 4303.29 of the Revised Code unless the permit is transferred to an economic development project.

(D) The division of liquor control shall refuse to issue, renew, transfer the ownership of, or transfer the location of a retail permit under this chapter if the applicant is or has been convicted of a violation of division (C)(1) of section 2913.46 of the Revised Code.

(E) The division of liquor control shall refuse to transfer the ownership of or transfer the location of a retail permit under this chapter while criminal proceedings are pending against the holder of the permit for a violation of division (C)(1) of section 2913.46 of the Revised Code. The department of job and family services shall notify the division of liquor control whenever criminal proceedings have commenced for a violation of division (C)(1) of section 2913.46 of the Revised Code.

(F) The division shall refuse to issue, renew, or transfer the ownership or location of a retail permit under this chapter if the applicant has been found to be maintaining a nuisance under section 3767.05 of the Revised Code at the premises for which the issuance, renewal, or transfer of ownership or location of the retail permit is sought.

I-Mart, 9171 Union Centre Blvd



I-Mart, 9171 Union Centre Blvd

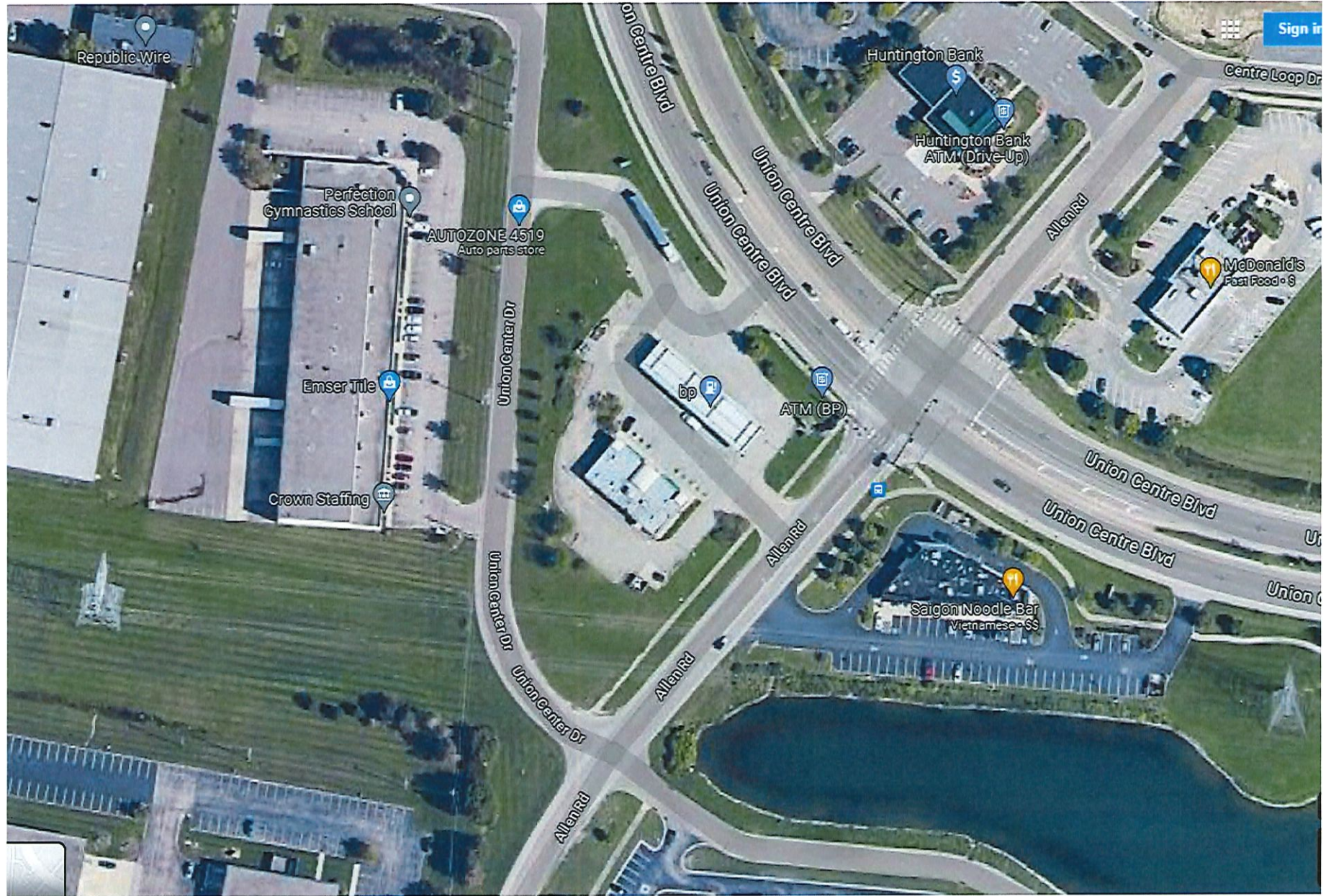

AGENDA ITEM COVER SHEET



Trustee Meeting Date:	Agenda Item Type:
October 24, 2023	Resolution Item
Submitted By:	
Aaron Wiegand, Director of Community Development	

Motion:
Motion to approve Resolution 42-2023 Implementing Sections 3735.65 through 3735.70 of the Ohio Revised Code; Establishing and Describing the Boundaries of the West Chester Township Community Reinvestment Area; Designating a Housing Officer to Administer the Program; Creating a Community Reinvestment Housing Council; and Creating a Tax Incentive Review Council

Background:
<p>West Chester Township is continuously seeking new avenues to support planned development in the Township. In early 2023, The Ohio Legislature passed legislation that permits limited home rule townships to create a Community Reinvestment Area program.</p> <p>This program provides property tax relief to developers who choose to develop within the established boundaries of the CRA. West Chester seeks to assist the area's development along Liberty Way and must first create the CRA district, which this legislation considers.</p> <p>Once the CRA is established, West Chester can work with developers to offer property-tax incentives to spur construction in the area. Those agreements will be subject to separate consideration by the West Chester Board of Trustees.</p> <p>In creating this CRA, West Chester has worked with Butler County and Lakota Schools, as well as Liberty Township.</p>

Finance	Budgeted Item:	N/A;		
	CIP #:			
	TIF Info:			
	Purchase Order:		Total Encumbrance:	\$.00

RESOLUTION NO. 42-2023

Resolution Implementing Sections 3735.65 through 3735.70 of the Ohio Revised Code; Establishing and Describing the Boundaries of the West Chester Township Community Reinvestment Area; Designating a Housing Officer to Administer the Program; Creating a Community Reinvestment Housing Council; and Creating a Tax Incentive Review Council

WHEREAS, the Ohio Community Reinvestment Area Act, under Section 3735.65 of the Ohio Revised Code, authorizes townships to designate areas as Community Reinvestment Areas; and

WHEREAS, the Board of Trustees of West Chester Township (hereinafter "Board") desires to pursue all reasonable and legitimate incentive measures to assist and encourage development in specific areas of West Chester Township that have not enjoyed reinvestment from remodeling or new construction; and

WHEREAS, a survey of housing (attached herein as "Attachment A"), as required by Section 3735.66 of the Ohio Revised Code, has been prepared for the area to be included in the proposed Community Reinvestment Area; and

WHEREAS, the survey of housing shows the facts and conditions relating to existing housing and commercial facilities and undeveloped areas, including, among other things, evidence of structures of historical significance and the discouragement of new housing construction and repair of existing facilities or structures within the proposed Community Reinvestment Area; and

WHEREAS, the maintenance of existing and construction of new structures in such area would serve to encourage economic stability, maintain real property values, and generate new employment opportunities; and

WHEREAS, the remodeling of existing structures or the construction of new structures in this Community Reinvestment Area constitutes a public purpose for which real property exemptions may be granted.

NOW THEREFORE, BE IT RESOLVED by the Board of Trustees, West Chester Township, Ohio:

Section 1. The area designated as the West Chester Township Community Reinvestment Area constitutes an area in which housing facilities are located and in which structures of historical significance are located, and new housing construction and repair of existing facilities or structures are discouraged.

Section 2. Pursuant to Section 3735.66 of the Ohio Revised Code, the West Chester Township Community Reinvestment Area is hereby established, comprised of the area within the following existing parcels as identified by the Butler County Auditor:

Parcel Numbers
M5610015000037
M5610015000014
M5610015000015
M5610015000001
M5610015000008
M5610015000018
M5610015000027
M5610015000018
M5610015000012

Only commercial, and/or industrial properties consistent with the applicable zoning regulations within the West Chester Township Community Reinvestment Area will be eligible for exemptions described herein. Residential construction and remodeling shall not be eligible for exemptions within West Chester Township Community Reinvestment Area.

Section 3. The entire area within the existing parcels identified in Section 2 as being within the designated Community Reinvestment Area are eligible for this incentive.

Section 4. Within the West Chester Township Community Reinvestment Area, the percentage of the tax exemption on the increase in the assessed valuation resulting from improvements to commercial and industrial real property and the term of those exemptions shall be negotiated on a case-by-case basis in advance of construction or remodeling occurring according to the rules outlined in the Section 3765.67 of the Ohio Revised Code. The results of the negotiation, as approved by this Commission, will be set in writing in a Community Reinvestment Area Agreement as outlined in Section

3735.671 of the Ohio Revised Code. A tax exemption on the increase in the assessed valuation resulting from the improvements as described in Ohio Revised Code Section 3735.67 shall be granted upon application by the property owner and certification thereof by the designated Housing Officer for the following periods:

Up to, and including, fifteen (15) years, and up to, and including, one hundred percent (100%) for the remodeling of existing commercial and industrial facilities and upon which the cost of remodeling is at least \$5,000, as described in Ohio Revised Code Section 3735.67, the term and percentage of which shall be negotiated on a case-by-case basis in advance of remodeling occurring.

Up to, and including, fifteen (15) years, and up to, and including, one hundred percent (100%) for the construction of new commercial or industrial facilities, the term and percentage of which shall be negotiated on a case-by-case basis in advance of construction occurring.

For the purposes of the above-described Community Reinvestment Area, structures or portions thereof exclusively used for residential purposes, regardless of the number of units contained therein, shall be classified as residential structures.

If remodeling qualifies for an exemption during the period of the exemption, the exempted percentage of the dollar amount of the increase in market value of the structure shall be exempt from real property taxation. If new construction qualifies for an exemption, during the period of the exemption, the exempted percentage of the structure shall not be considered to be an improvement on the land on which it is located for the purpose of real property taxation.

Section 5. To administer and implement the provisions of this Resolution, the Director of Community Development is designated as the Housing Officer as described in Sections 3735.65 through 3735.70.

Section 6. That the Board shall cause a Housing Council as described in Section 3735.69 of the Ohio Revised Code to be appointed. The Housing Council shall be composed of two members appointed by the Board, one member appointed by the Township Law Director, one member appointed by the Township zoning commission,

and one member appointed by the Board of Commissioners of Butler County.

Section 7. To the extent necessary and required under the Ohio Revised Code as a result of the establishment of the West Chester Township Community Reinvestment Area, a Tax Incentive Review Council shall be established pursuant to Section 5709.85 of the Ohio Revised Code and shall consist of the members of this Board, the County Auditor or its designee; and an individual appointed by the Board of Education of the Lakota Local School District. The Tax Incentive Review Council shall review annually the compliance of all CRA agreements involving the granting of exemptions for commercial or industrial real property improvements under Section 3735.671 of the Ohio Revised Code and make written recommendations to the Board as to continuing, modifying, or terminating said CRA agreements based upon the performance of the terms and conditions of said agreements.

Section 8. The Housing Officer shall make an annual inspection of the properties within the district for which an exemption has been granted under Section 3735.67 of the Ohio Revised Code. The Housing Council shall also hear appeals under Section 3735.70 of the Ohio Revised Code.

Section 9. The Board hereby finds and determines that all formal actions relative to the passage of this Resolution were taken in an open meeting of this Board, that all deliberations of this Board and of its committees, if any, which resulted in formal action were taken in meetings open to the public, in full compliance with the applicable legal requirements, including Section 121.22 of the Ohio Revised Code.

Adopted this 14 day of November 2023.

Ann Becker, Chair

Yes/No

ATTEST:

Lee Wong, Vice Chair

Yes/No

Bruce Jones, Fiscal
Officer

Mark Welch, Trustee

Yes/No

APPROVED AS TO FORM:

Donald L. Crain, Law Director

ATTACHMENT A

HOUSING SURVEY

DRAFT

WEST CHESTER TOWNSHIP

COMMUNITY REINVESTMENT AREA HOUSING SURVEY



October 18, 2023

PREPARED BY:

Frost Brown Todd LLP
October 18, 2023

TABLE OF CONTENTS

PURPOSE AND SCOPE	1
--------------------------	----------

WEST CHESTER TOWNSHIP	3
------------------------------	----------

Demographics...	4
-----------------	---

Employment.....	5
-----------------	---

General Housing Characteristics of the Township	5
---	---

PROPOSED CRA	6
---------------------	----------

Structure of Historical Significance.....	7
---	---

Vacant Land	8
-------------------	---

CONCLUSIONS	9
--------------------	----------

TABLE OF FIGURES

<i>Figure 1. Map of Proposed Community Reinvestment Area</i>	<i>2</i>
--	----------

<i>Figure 2. Map of Butler County (West Chester Township Highlighted in Red).....</i>	<i>3</i>
---	----------

<i>Figure 3. Population Characteristics</i>	<i>4</i>
---	----------

<i>Figure 4. Population Growth.....</i>	<i>4</i>
---	----------

<i>Figure 5. Butler County Employment</i>	<i>5</i>
---	----------

<i>Figure 6. Year Structures Built.....</i>	<i>6</i>
---	----------

<i>Figure 7. Gross Rent.....</i>	<i>6</i>
----------------------------------	----------

West Chester Township
Community Reinvestment Area
Housing Survey

PURPOSE AND SCOPE

This Community Reinvestment Area Housing Survey (the “Housing Survey”) constitutes a component of the statutory framework necessary to properly designate an area as a Community Reinvestment Area (“CRA”) as defined in Sections 3735.65 through 3735.70 of the Ohio Revised Code (the “ORC”). West Chester Township, Butler County, Ohio (the “Township”) has undertaken this Housing Survey in accordance with ORC Section 3735.66.

The CRA program permits townships to designate areas where investment has been discouraged as a CRA in order to encourage revitalization of existing housing and building stock, and the construction of new structures. Specifically, the purpose of this Housing Survey is to determine whether the area within the Township shown in Figure 1 below (the “Proposed CRA”) is an area in which “housing facilities or structures of historical significance are located and new housing construction and repair of existing facilities or structure are discouraged. As of the date hereof, the property within the boundary of the Proposed CRA includes the following parcels:

Parcel Number

- Parcel A - M5610015000037
- Parcel B - M5610015000014
- Parcel C - M5610015000015
- Parcel D - M5610015000001
- Parcel E- M5610015000008
- Parcel F - M5610015000018
- Parcel G - M5610015000027
- Parcel H - M5610015000018
- Parcel I - M5610015000012

The Proposed CRA is located in an area approximately one mile east of Interstate 75, generally bounded by Tylersville Road to the South and Butler Warren Road to the east. The proposed CRA contains approximately 450 acres of land, a public park, a structure of historical significance, and various other structures, including a lodge and an athletic field house.

As described in greater detail herein, creation and implementation of the Proposed CRA will encourage economic development within the Proposed CRA. Formation of the Proposed CRA will also provide the Township with a tool to incentivize construction and economic development in a way that optimizes land use for the benefit of existing and future residents, visitors and business operators within and proximate to the Proposed CRA.

Figure 1. Proposed CRA

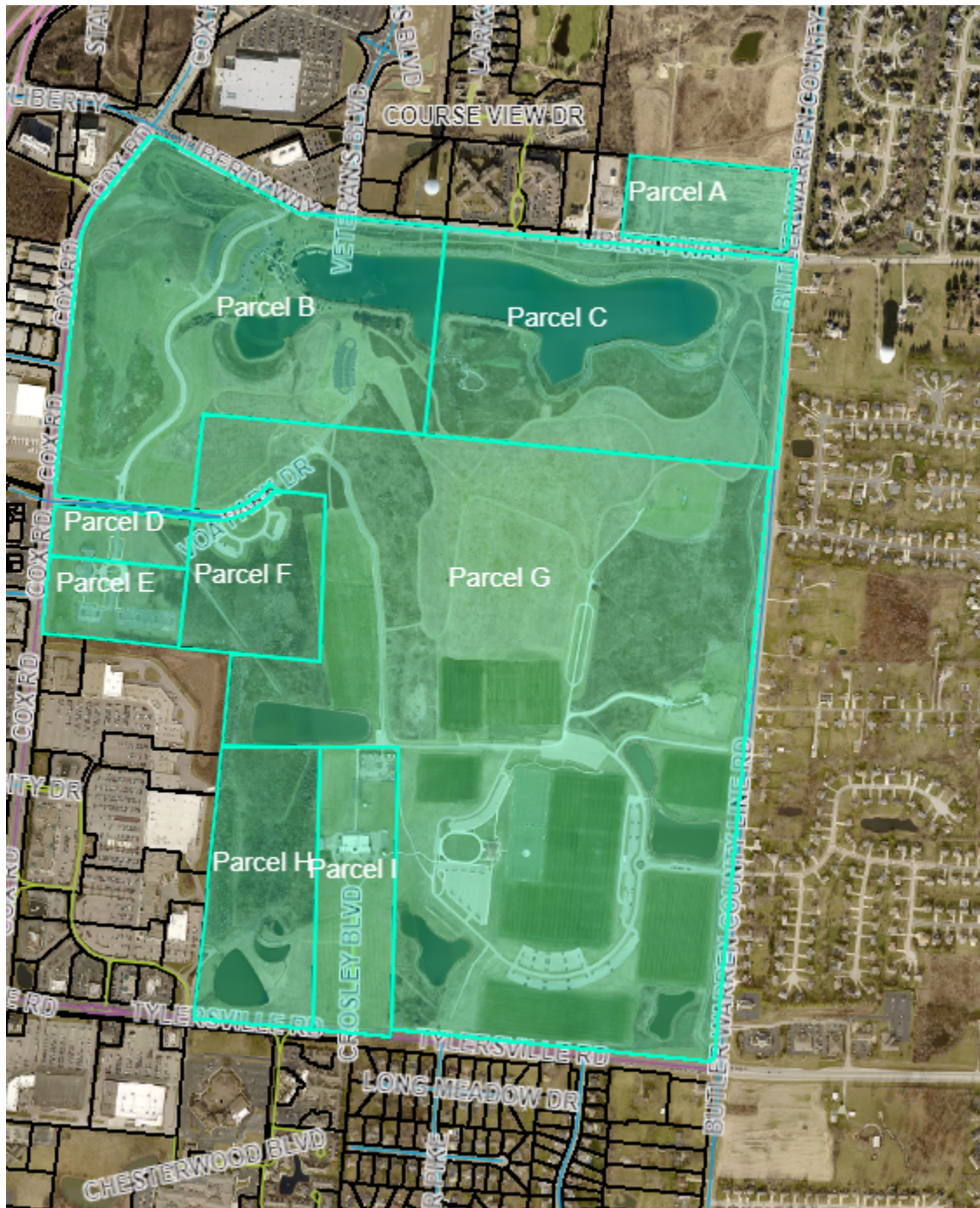

WEST CHESTER TOWNSHIP

West Chester Township is located in Butler County in southwestern Ohio. The Township is situated centrally in the Cincinnati-Dayton Metroplex, a major commerce corridor linking the metropolitan regions of Cincinnati and Dayton. West Chester is located just north of I-275, Cincinnati's regional beltway, approximately 18 miles north of downtown Cincinnati, Ohio and 30 miles south of downtown Dayton, Ohio. West Chester is the southern gateway to Butler County, which links Hamilton County (Cincinnati) to the south and Montgomery County (Dayton) to the north. The Township has, and continues to, benefited from the convergence of the Cincinnati and Dayton metro areas along the I-75 corridor.

West Chester Township is a community located in the heart of Greater Cincinnati's fast growing northern suburbs, with a population of 64,830 according to the 2020 U.S. Census and an estimated population of 66,182 in the year 2025¹.

Geographically, the Township consists of 35 square miles of residential neighborhoods, commercial, and industrial developments. West Chester Township is the only community located in the tri-state region, other than the urban center city of Cincinnati, with four full-access interstate interchanges on I-75. Two additional interstate exchanges to the regional beltway I-275 are located within a quarter mile of West Chester's perimeter.

Figure 2. Map of Butler County (West Chester Township Highlighted in Red)

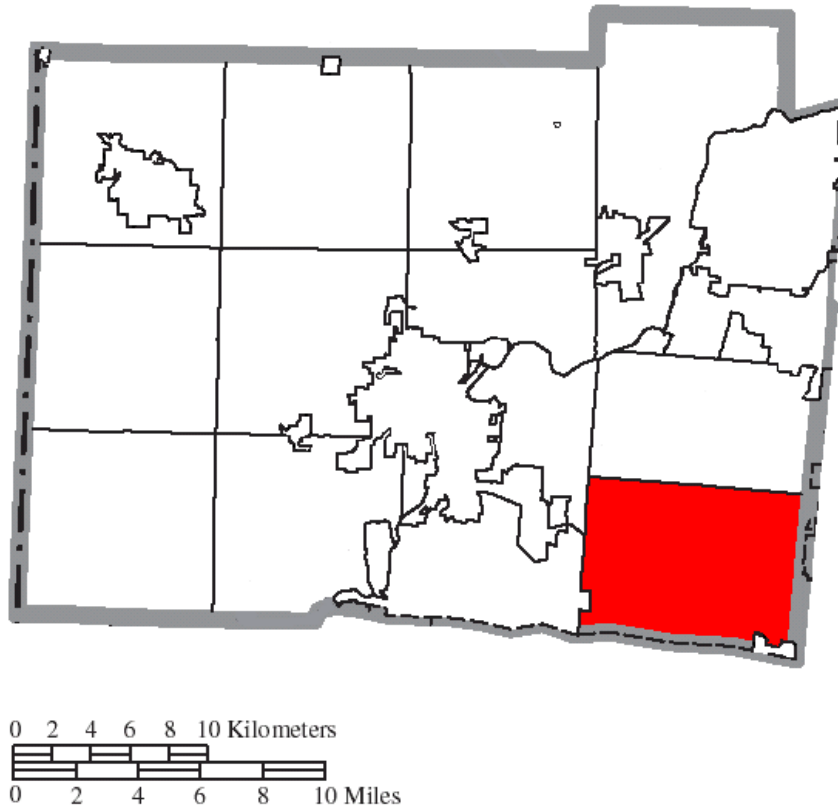

¹ SitesUSA

Demographics

Demographic and socio-economic characteristics provided by the U.S. Census Bureau and the Ohio Department of Job and Family Services are described to identify past conditions and trends in the community. The statistical information in this section, unless otherwise noted, was derived from census reports published by the U.S. Census Bureau and reports published by the Ohio Department of Job and Family Services. Inconsistencies in the data are possible based on how census data is collected. In addition to errors occurring during collection, much of the census data presented in this report is based on sample data rather than 100% reporting and is therefore subject to sampling error. Because of sampling errors and non-sampling errors, there may be discrepancies in the reporting of similar types of data. However, the discrepancies will not negate the usefulness of the census data to conduct the analysis.

Figure 3. Population Characteristics

	West Chester Township		Butler County	
	Number	Percent	Number	Percent
Population	64,509	-	387,830	-
Median Age	38.8 years	-	37 years	-
Under 5 years	4,189	6.5%	23,080	6.0%
18 years and over	48,044	74.5%	296,271	76.4%
65 years and over	10,058	15.6%	57,321	14.8%
Male Population	31,844	49.4%	191,072	49.3%
Female Population	32,665	50.6%	196,758	50.7%

Source: U.S. Census Bureau, 2021: American Community Survey 5-Year Estimates

Figure 4. Population Growth

	West Chester Township (Growth %)		Butler County (Growth %)	
1970	12,795	-	226,207	-
1980	23,553	84.1%	258,787	14.4%
1990	39,703	68.6%	291,479	12.6%
2000	54,895	38.3%	332,705	14.1%
2010	60,958	11.4%	368,130	10.6%
2021	64,509	5.8%	387,830	5.4%

Source: Ohio Municipal Advisory Council

Figure 5. Butler County Employment

<u>Year</u>	<u>Employed In</u>		<u>Unemployment Rate</u>			
	<u>County</u>	<u>MSA²</u>	<u>County</u>	<u>MSA²</u>	<u>State</u>	<u>U.S.</u>
2013	172,300	761,200	7.5	7.3	7.5	7.4
2014	176,100	776,000	5.6	5.5	5.8	6.2
2015	178,700	785,800	4.6	4.5	4.9	5.3
2016	180,900	795,400	4.5	4.4	5.0	4.9
2017	183,700	802,300	4.4	4.4	5.0	4.4
2018	185,100	812,300	4.1	4.1	4.6	3.9
2019	187,700	1,085,200	3.8	3.7	4.1	3.7
2020	179,400	1,036,700	7.3	7.0	8.2	8.3
2021	186,400	1,075,000	4.5	4.4	5.1	5.3
2022 ³	186,900	1,120,200	3.7	3.6	4.1	3.4

Source: U.S. Census Bureau, 2012-2021 American Community Survey 5-Year Estimates

The Township and regional demographic and employment statistics and trends presented above demonstrate strong economic growth. In order continue such growth and advance future economic development, the Township must accommodate current and future residents. The County and Township require the means to incentivize economic development in a manner that complements existing housing stock and does not stifle planned future housing development.

General Existing Housing Characteristics

West Chester Township has an estimated 24,971 housing units, of which approximately 825 are vacant. The median home value in West Chester Township is \$252,100 (based on Census estimates). The below tables contain general information about housing stock characteristics for West Chester Township:

Figure 6. West Chester Township Housing Occupancy

	West Chester Township		Butler County	
	Number	Percent	Number	Percent
Total Housing Units	24,971	-	153,416	-
Occupied Units	24,146	96.7%	142,881	93.1%
Owner-Occupied	18,245	76.9%	99,432	69.6%
Renter-Occupied	5,943	23.1%	43,449	30.4%
Vacant Units	825	3.3%	10,535	6.9%

² Cincinnati Metropolitan Statistical Area – Brown, Butler, Clermont, Hamilton and Warren Counties, Ohio. 2019 and 2020 include Kenton, Boone, Campbell, Grant, Pendleton, Gallatin and Bracken Counties, Kentucky and Dearborn, Franklin, Union and Ohio Counties, Indiana in the MSA

³ October 2022

Figure 7. Year Structures Built

	West Chester Township		Butler County	
	Number	Percent	Number	Percent
Total Housing Units	24,971	-	153,416	-
Built 2020 or later	22	0.1%	145	0.1%
Built 2010 to 2019	1,558	6.2%	7,790	5.1%
Built 2000 to 2009	2,939	11.8%	21,386	13.9%
Built 1990 to 1999	6,588	26.4%	23,498	15.3%
Built 1980 to 1989	5,868	23.5%	17,865	11.6%
Built 1970 to 1979	4,611	18.5%	26,758	17.4%
Built 1960 to 1969	1,992	8.0%	14,252	9.3%
Built 1950 to 1959	773	3.1%	17,673	11.5%
Built 1940 to 1949	239	1.0%	6,197	4.0%
Built 1939 or earlier	381	1.5%	17,852	11.6%

Figure 8. Gross Rent

	West Chester Township		Butler County	
	Number	Percent	Number	Percent
Occupied Units Paying Rent	5,300	-	41,372	-
Less than \$500	67	1.3%	2,776	6.7%
\$500 to \$999	1,308	24.7%	19,812	47.9%
\$1,000 to \$1,499	2,364	44.6%	14,169	34.2%
\$1,500 to \$1,999	1,154	21.8%	3,077	7.4%
\$2,000 to \$2,499	287	5.4%	946	2.3%
\$2,500 to \$2,999	81	1.5%	375	0.9%
\$3,000 or more	39	0.7%	217	0.5%
Median (dollars)	1,238	(X)	966	(X)
No rent paid	272	(X)	2,077	(X)

PROPOSED CRA

Located on Parcel I within the proposed CRA is the Voice of America Bethany Relay Station and ancillary structures, which comprise a former radio broadcast station that is currently listed on the National Register of Historic Places. The station ceased broadcasting in 1994 and has since been transformed into the National Voice of America Museum of Broadcasting. The museum is operated primarily by volunteers and offers guided tours and various exhibits that detail the rich history of broadcasting within the greater Cincinnati area as well as the historical significance of the station.

While the majority of the residential and commercial properties within West Chester Township are in good condition, the area within the proposed CRA is undeveloped or underdeveloped. A number of contributing factors exist that discourage development within the area of the proposed CRA, including its location within the Township. Parcel A located within the CRA consists of vacant and undeveloped land located along the boundary line of the Township that directly abuts Liberty Way and Butler Warren Road. This vacant land is currently surrounded

by additional undeveloped land to the west and the Voice of America Park MetroPark to the south. The isolated nature of the location of the land creates a disincentive for development in the area.

Equipped with the ability to provide the proper incentives, the Township can better encourage the highest and best use of this vacant, undeveloped land. For example, the Township may incentivize commercial and industrial use of land within portions of the CRA in order to make other, better-situated parcels available for single-family housing by increasing the local availability of goods and services.

Structure of Historical Significance

Property Address: 8070 Tylersville Rd, Crosly Blvd, West Chester Township, OH 45069
Parcel Number: M5610015000012
Property Assessed Value: \$1,885,110



Vacant Land

Property Address: Butler Warren Rd. & Liberty Way, West Chester Township, OH 45069

Parcel Number: M5610015000037

Property Assessed Value: \$1,622,660



CONCLUSION

The designation of the Proposed CRA for West Chester Township is intended to encourage economic development, construction of additional housing in the Township generally, and the development of vacant land. The data within this Housing Survey demonstrates that the Proposed CRA shown in Figure 1 is an area that has experienced disinvestment, includes underutilized and undervalued property, includes structures of historical significance, and has seen little investment. CRA implementation will provide the opportunity to control and optimize housing development and economic development generally within the Proposed CRA, the Township and the County.

In conclusion, this Housing Survey demonstrates that the Proposed CRA meets the criteria for a Community Reinvestment Area as defined by Ohio Revised Code.

0091532.0268857 4888-9977-1784v2

AGENDA ITEM COVER SHEET



Trustee Meeting Date:	Agenda Item Type:
November 14, 2023	Resolution Item
Submitted By:	
Aaron Wiegand, Director of Community Development	

Motion:
Resolution 46-2023 approving Zoning Map Amendment for Case # ZMA07-23 McNally Property (To be read at public hearing)

Background:
<p>The following case is scheduled for a 7:00 p.m. Public Hearing and 1st Reading on November 14, 2023:</p> <ul style="list-style-type: none"> Case # ZMA 07-23 McNally Property <p>The applicant is requesting approval for a Zoning Map Amendment from R-1 (Suburban Residence District) to B-1 (Neighborhood Business District) located at 8662 Cincinnati Dayton Road. Parcel # M5610-023-000-034</p>

Finance	Budgeted Item:	N/A;		
	CIP #:			
	TIF Info:			
	Purchase Order:		Total Encumbrance:	\$.00

DRAFT



WCT Board of Trustees Staff Report

October 16, 2023

**CASE NO. ZMA 07-23
MCNALLY PROPERTY**

REQUEST: Zoning Map Amendment - District Reclassification

FROM: R-1 (Suburban Residence District)

TO: B-1 (Neighborhood Business District)

PROPERTY OWNER: James & Flor de Maria McNally

APPLICANT: James & Flor de Maria McNally

LOCATION: The subject site is located along the east side of Cincinnati-Dayton Road, approximately 200 feet north of Cresthaven Ave (Parcel M5610023000034; Section 22, Town 3, Range 2).

SITE DESCRIPTION: The subject site consists of one (1) lot totaling .86 acres. The site is characterized as sloping from west to east with a mature tree line along the east property line.

Current Zoning:

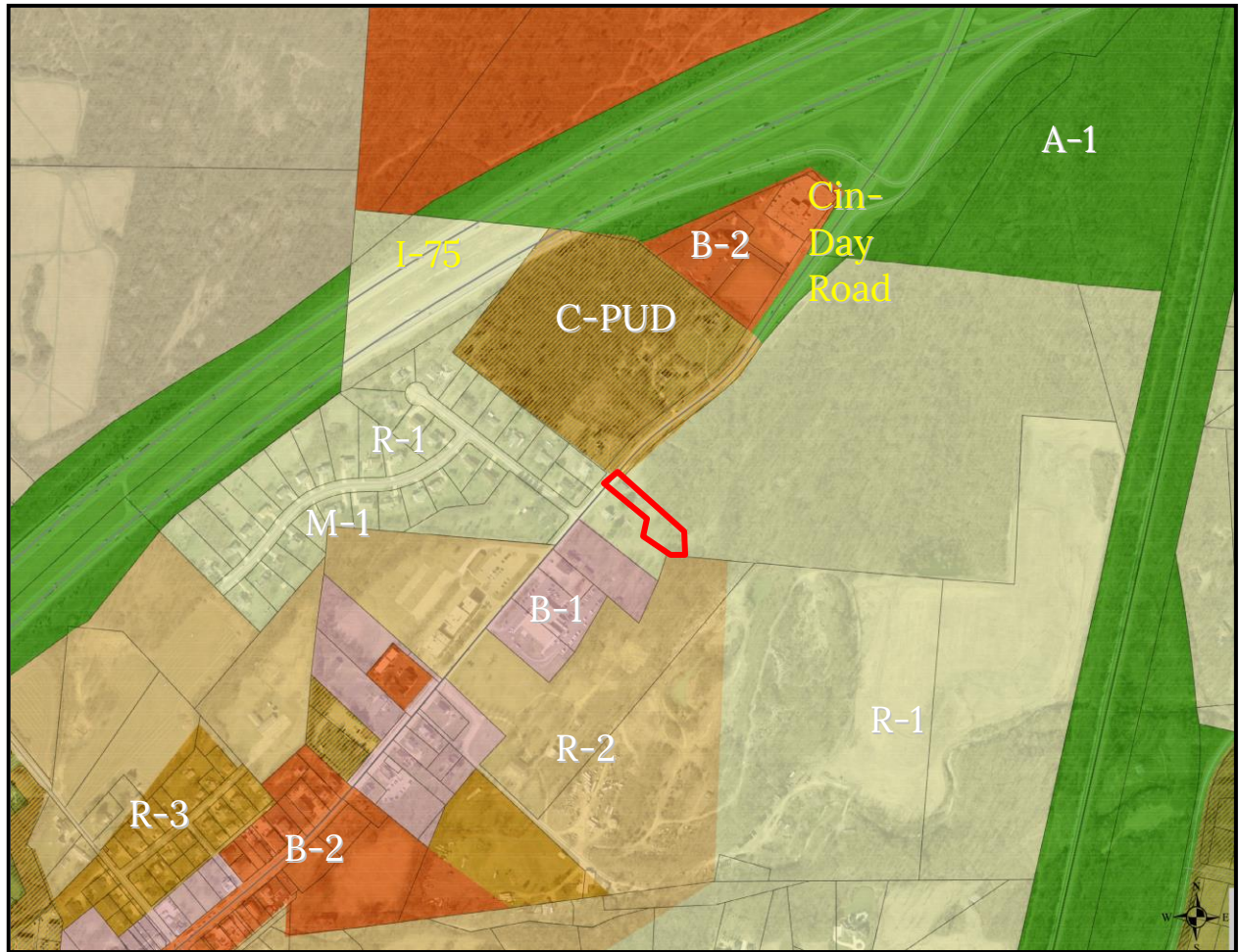

**SURROUNDING
CONDITIONS:**

Existing Zoning

North:	R-1	Suburban Residence District
East:	R-2	Single-Family Residence District
South:	B-1	Neighborhood Business District
West:	R-1	Suburban Residence District

Proposed Land Use Map:



The West Chester Township Comprehensive Land Use Plan (CLUP) proposes Neighborhood Retail as the adopted land use recommendation for the subject site.

- **Neighborhood Retail** - “Low intensity, neighborhood-oriented retail and service uses that provide a transition between residential uses and other types of development or that achieve compatibility with and provide services to adjacent residential areas.”

General Location and Development Characteristics:

- Road frontage on or near a major road corridor or intersection;
- Small or unique sites, generally not exceeding three acres;
- Adjacent to or near residential areas;

- Neighborhood identity and services;
- Buildings and structures at a residential scale;
- Buildings and parking areas buffered and screened from adjacent residential areas and rights-of-way;
- Designed to encourage easy pedestrian access; and
- Access points consolidated with adjacent developments to minimize curb-cuts along main roadways and provide cross-access with adjoining parcels.

STAFF

CONSIDERATIONS:

The applicant has stated the intention for the rezoning is to bring the current zoning into conformity with the recommend land use and convert the existing residential use to an office use.

The Butler County Planning Commission held a public hearing on October 10th and the Township Zoning Commission held a public hearing on October 16th and given all considerations in regard to the existing conditions; the proposed use in relation to the surrounding character; and the overall general welfare of the County and Township, the Commissions recommended approval of the zoning map amendment.

All other development standards will be pursuant to the WCTZR in regard to office uses at the permitting stage.

ACTION: The West Chester Township Board of Trustees may now approve or deny of the submitted Zoning Map Amendment, unless additional information is deemed necessary to make an informed decision.



Application for a
ZONING MAP AMENDMENT

WEST CHESTER COMMUNITY DEVELOPMENT DEPARTMENT
9577 BECKETT ROAD • SUITE 100 • WEST CHESTER, OHIO 45069-5014



<p>A. APPLICANT INFORMATION</p> <p>NAME: <u>James McNally & Flor de Maria McNally</u> PHONE: (410) <u>935</u> - <u>5726</u></p> <p>ADDRESS: <u>8002 Jasmine Trail</u></p> <p>CITY/ST/ZIP: <u>West Chester, OH 45241</u></p> <p>EMAIL: <u>jim@demariahomes.com & Flor@demariahomes.com</u></p> <p>APPLICANT IS THE: <input checked="" type="checkbox"/> PROPERTY OWNER <input type="checkbox"/> AGENT <input type="checkbox"/> OPTIONEE</p>	<p style="writing-mode: vertical-rl; transform: rotate(180deg);">WEST CHESTER COMMUNITY DEVELOPMENT DEPARTMENT</p> <div style="border: 2px solid red; padding: 5px; display: inline-block;"> <p style="color: red; font-weight: bold; font-size: 1.2em;">RECEIVED</p> <p style="color: red; font-weight: bold; font-size: 1.2em;">SEP 8 2023</p> </div> <p style="writing-mode: vertical-rl; transform: rotate(180deg);">DATE OF APPLICATION <u>Property</u></p> <p style="writing-mode: vertical-rl; transform: rotate(180deg);">CASE # <u>ZMA07-23 McNally</u></p>
<p>B. PROPERTY INFORMATION</p> <p>PROPERTY ADDRESS (IF ANY): <u>8662 Cincinnati Dayton Rd</u></p> <p>CITY/ST/ZIP: <u>West Chester, OH 45069</u></p> <p>SECTION: <u>22</u> TOWN: <u>3</u> RANGE: <u>2</u> PARCEL #: <u>M 5610 -023 -000 -034</u></p> <p>CURRENT USE OF PROPERTY (CHECK ALL THAT APPLY):</p> <p><input type="checkbox"/> COMMERCIAL <input checked="" type="checkbox"/> RESIDENTIAL <input type="checkbox"/> AGRICULTURAL <input type="checkbox"/> OTHER</p>	<p style="text-align: center;">PAYMENT INFORMATION</p> <p>FEE AMOUNT: \$750.00</p> <p>RECEIPT #: <u>684</u></p> <p>RECEIVED BY: <u>Bjkk</u></p>
<p>C. PROPERTY ZONING</p> <p>CURRENT ZONING OF PROPERTY: <u>R-1</u></p> <p>REQUESTED ZONING OF PROPERTY: <u>B-1</u></p> <p>TOTAL ACRES OF PROPERTY TO BE REZONED: <u>0.867</u></p>	<p>D. PROPERTY OWNER INFORMATION (LIST ALL PARCELS AND PROPERTY OWNERS THAT ARE INCLUDED WITH THIS APPLICATION)</p> <p>1. PARCEL #: <u>M 5610 -023 -000 -034</u></p> <p>NAME: <u>James & Flor de Maria McNally</u> PHONE: (410) <u>935</u> - <u>5726</u></p> <p>ADDRESS: _____</p> <p>2. PARCEL #: <u>M</u> - - -</p> <p>NAME: _____ PHONE: () - -</p> <p>ADDRESS: _____</p> <p>3. PARCEL #: <u>M</u> - - -</p> <p>NAME: _____ PHONE: () - -</p> <p>ADDRESS: _____</p> <p>4. PARCEL #: <u>M</u> - - -</p> <p>NAME: _____ PHONE: () - -</p> <p>ADDRESS: _____</p>
<p>E. DESCRIPTION OF REQUEST</p> <p><u>Request is to be able to operate a small real estate office at this location.</u></p> <p><u>4-5 employees to work at this location daily.</u></p> <p>_____</p> <p>_____</p>	

As the Applicant, I do hereby agree that I am the Property Owner, or I am submitting this application on behalf of the Property Owner with their knowledge and understanding. Furthermore, I hereby certify that the information and statements provided on this application, drawings and specifications are true and correct to the best of my knowledge and belief. I understand that all information submitted with this application will be assumed to be correct and the Applicant shall assume responsibility for any errors and/or inaccuracies resulting in an improper application.

Printed Name: _____ Date: 9/8/2023 | 8:31 AM EDT

Applicant Signature: James McNally
 Date: _____

4E478584A0584BA...



Submission Instructions and Requirements for a
ZONING MAP AMENDMENT



DESCRIPTION OF REQUEST AND REASONS FOR ZONING MAP AMENDMENT FORM

The area of land sought to be rezoned contains approximately 0.867 acres, having frontage of approximately 56.8 feet located (1) along the South side of Cincinnati Dayton Rd, approximately 190 feet from Cresthaven Avenue. Or (2) at the _____ corner of the intersection of _____ and _____.

THE APPLICANT SHOULD PREPARE DEFINITIVE STATEMENTS REGARDING THE FOLLOWING:

1. WHAT ARE THE SPECIFIC CHANGES IN THE CHARACTER AND CONDITIONS OF THE AREA WHICH HAVE OCCURRED TO MAKE THE PROPERTY NO LONGER SUITABLE OR APPROPRIATE FOR THE EXISTING ZONING CLASSIFICATION OR TO MAKE THE PROPERTY APPROPRIATE FOR THE PROPOSED ZONE DISTRICT? *Most of the properties along the CinDay Olde West Chester strip are commercial. Making our property commercial will continue to make this a hub for various community service needs.*
2. WHAT IS THE BENEFIT THAT THE NEIGHBORHOOD OR COMMUNITY AS A WHOLE WILL DERIVE FROM THIS ZONE CHANGE? *The neighborhood will derive great benefit from the traffic generated by our small business. We also serve 100s of Latinos in all of greater Cincinnati so well be introducing diversity to our community.*
3. WILL THE SITE BE ACCESSIBLE FROM PUBLIC ROADS WHICH ARE ADEQUATE TO CARRY THE TRAFFIC THAT WILL BE IMPOSED UPON THEM IF THE REZONING IS GRANTED, OR WILL ROAD IMPROVEMENTS BE REQUIRED? *The site is accessible from public roads, roads are adequate for traffic and no improvements will be necessary.*
4. HAS THIS REZONING BEEN DISCUSSED WITH REGARD TO TRAFFIC DESIGN WITH THE BUTLER COUNTY ENGINEER'S OFFICE? WHEN? WHO? *No discussion due to the minimal impact rezoning will have on traffic patterns. We've added sufficient parking for the square footage of the house.*
5. IS THE PROPERTY CURRENTLY OR CAN IT BE SERVICED BY PUBLIC SEWER AND WATER AND CAN PROPER DRAINAGE BY PROVIDED? *Yes, currently serviced by public sewer and water, yes, there is currently proper drainage.*
6. WHAT IS THE ANTICIPATED PROPOSED USE PROPERTY AND CHARACTER (ARCHITECTURAL TREATMENT) OF THE DEVELOPMENT? *The anticipated use is real estate office space. we will hold client consultations, team meetings, and closings here. The architectural treatment will remain the same.*

ARNOLD SURVEYING LLC
 3017 BELLE MEADE LN.
 EDGEWOOD, KY. 41017
 513-505-4486

ZONING PLAT
 SECTION 22, TOWN 3, RANGE 2, MIAMI
 PURCHASE, WEST CHESTER TOWNSHIP,
 BUTLER COUNTY, OHIO
 FLOR DE MARIA AND JAMES MCNALLY
 8662 CINCINNATI DAYTON ROAD
 WEST CHESTER, OH. 45241

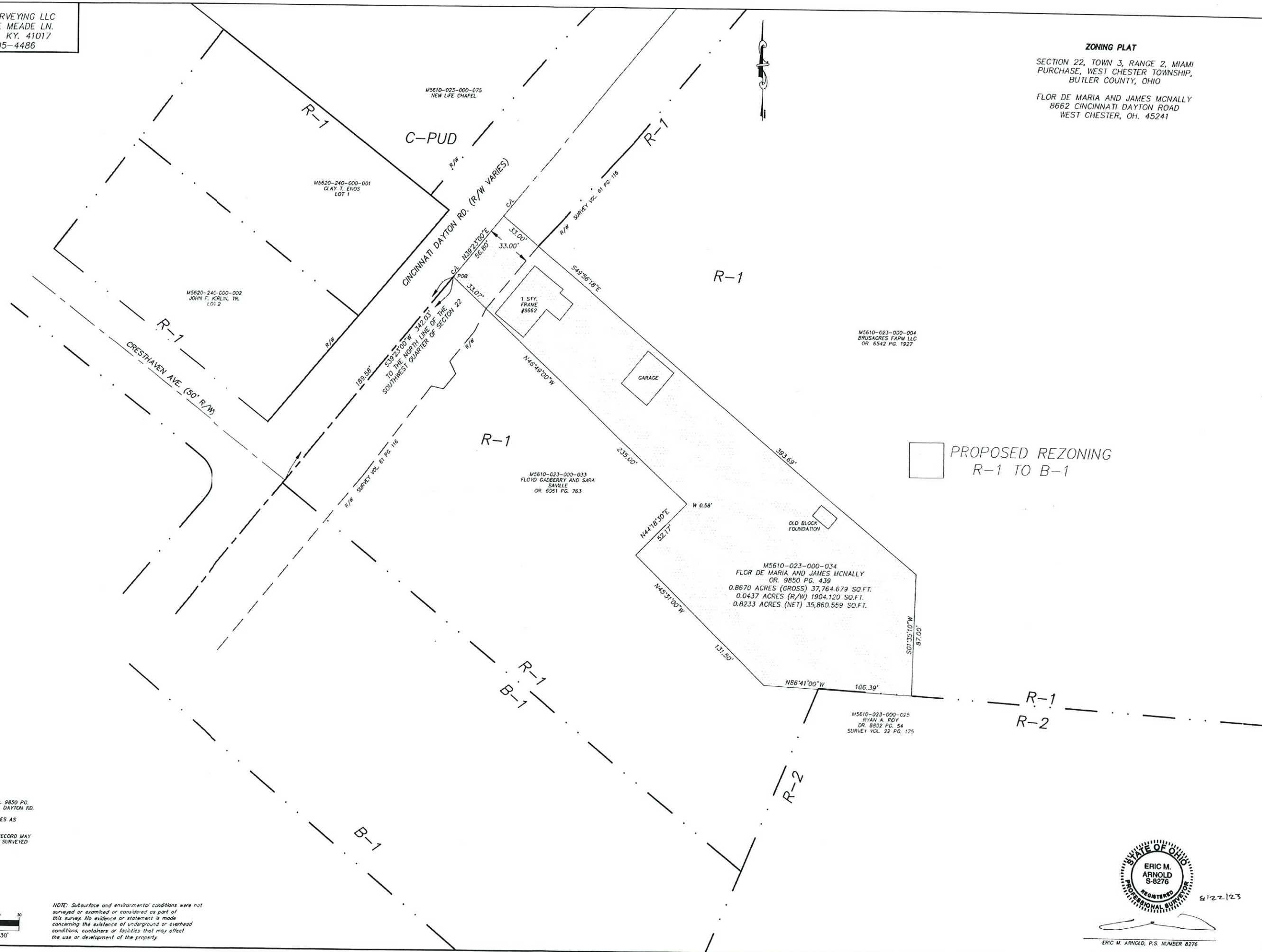

PROPOSED REZONING
 R-1 TO B-1

BEARINGS BASED ON OR. 9850 PG.
 439 CENTERLINE OF CIN. DAYTON RD.
 SURVEY/DEED REFERENCES AS
 SHOWN HEREON
 OTHER DOCUMENTS OF RECORD MAY
 EXIST THAT AFFECT THE SURVEYED
 PROPERTY

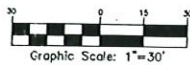

NOTE: Subsurface and environmental conditions were not surveyed or examined or considered as part of this survey. No evidence or statement is made concerning the existence of underground or overhead conditions, containers or facilities that may affect the use or development of the property.

M5610-023-000-034
 FLGR DE MARIA AND JAMES MCNALLY
 OR. 9850 PG. 439
 0.8670 ACRES (GROSS) 37,764.679 SQ.FT.
 0.0437 ACRES (R/W) 1904.120 SQ.FT.
 0.8233 ACRES (NET) 35,860.559 SQ.FT.

M5610-023-000-025
 RYAN A ROY
 OR. 8802 PG. 24
 SURVEY VOL. 22 PG. 175



8/22/23

ERIC M. ARNOLD, P.S. NUMBER 8276

AGENDA ITEM COVER SHEET



Trustee Meeting Date:	Agenda Item Type:
November 14, 2023	Emergency Resolution Item
Submitted By:	
Arun Hindupur, Director of Public Works/Community Services	

Motion:
Motion to approve Emergency Resolution 47-2023 authorizing the removal of snow and ice from undedicated roads in accordance with Ohio Revised Code section 505.82 and pursuant to Limited Home Rule Authority provided under Ohio Revised Code chapter 504 and declaring an emergency and dispensing with the second reading

Background:
<p>During the winter season, the Community Services Department has expanded its capacity to respond to winter weather emergencies by providing service to the undedicated streets within the Township.</p> <p>In the past, the practice was to allow for the undedicated streets to be maintained by the developer or owner of the property prior to acceptance by the Board of Trustees. In many instances, these streets would go unmaintained during winter weather storms creating both an inconvenience to those traveling the roads and a public safety hazard.</p> <p>Approval of this Resolution will authorize the Township to solicit from the developer/owner the name of the party that will be maintaining that stretch of roadway undedicated to the Township. In the event that the developer chooses the Township as the service provider, we propose to offer service during inclement weather at a cost of \$0.075 per linear foot, as outlined under Section 505.82 of the ORC.</p> <p>The cost to the developer is charged based on a linear footage and the amount of times that the Township must pass over this same stretch of roadway. This practice has been used during past winter seasons and has been found to be successful.</p>

Finance	Budgeted Item:	N/A;		
	CIP #:			
	TIF Info:			
	Purchase Order:		Total Encumbrance:	\$.00

RESOLUTION NO. 47-2023

Emergency Resolution Authorizing the Removal of Snow and Ice from Undedicated Roads in Accordance with Ohio Revised Code Section 505.82 and Pursuant to Limited Home Rule Authority Provided Under Revised Code Chapter 502 and Declaring an Emergency and Dispensing with the Second Reading

WHEREAS, West Chester Township is a limited home rule Township pursuant to Ohio Revised Code, Chapter 504; and,

WHEREAS, when winter conditions arise, residents on undedicated road(s) in West Chester Township may be adversely impacted if an owner(s) or developer(s) of undedicated road(s) have not provided for removal of snow and ice; and,

WHEREAS, when there is no method to guarantee undedicated roads will be properly treated, and snow and ice properly removed, an immediate danger to the health, safety and welfare of the inhabitants of the undedicated road(s) exists; and,

WHEREAS, pursuant to Ohio Revised Code, Section 505.82 (A), the Township may appropriately notice and apply an equitable service charge for the removal or other treatment of snow and ice, and charge the owner(s) of undedicated road(s) when Township resources are used to remove snow and ice from or to treat accordingly the undedicated road(s); and,

WHEREAS, pursuant to Ohio Revised Code, Section 505.82 (B), the Township may enter into a contract with a developer whereby the developer agrees to pay the service for the removal or other treatment of snow and ice instead of the owners.

NOW, THEREFORE BE IT RESOLVED the West Chester Township Board of Trustees, by authority of Chapter 504 and Section 505.82 of the Ohio Revised Code, does hereby agree to:

SECTION 1. Define an emergency is and declare one arises from the obstruction by snow and ice on certain undedicated road(s) in the Township.

SECTION 2. Authorize the Township Administrator or her designee to cause for the removal or other treatment of snow and ice as provided for in Ohio Revised Code Section 505.82 (A) and (B).

SECTION 3. Determine, pursuant to Section 505.82 of the Ohio Revised Code, this Resolution shall remain in effect until April 30, 2024.

SECTION 4. Find and determine that all formal actions relative to the passage of this Resolution were taken in an open meeting of this Board, and that all deliberations of this Board and of its Committees, if any, which resulted in formal action, were taken in meetings open to the public, in

